

4mm Scale Locomotive Lamps
4mm Scale 2-colour side Lamps

General instructions and installation guidance

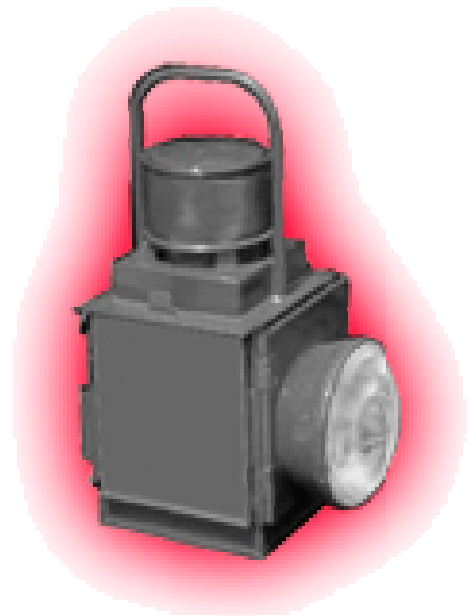

Thank you for purchasing our 4mm scale lamps.

We have created them based on actual prototype BR/LMS lamps and we have done our very best to ensure that not only are they as accurate as we can make them, but also easy to install and reliable in use.

The prototype on which we based our lamp is shown here:

About our lamps:

They are available in white, red and red+white. You will find in each pack 6 lamps and a selection of resistors. All lamps are made from carbon filled polycarbonate which is very strong and prevents excessive light bleed.

The lamp handle is made from ultra fine springy wire to keep it scale size and it has been hinged to ensure it will not be easy to damage. This hinging of the handle also makes it easy to place the lamp in the hands of a scale-sized guard or loco crew, to make a wonderful “working lamp” scene in loco depot or at a station somewhere....

Being made of a carbon filled material, all lamps are black as supplied, and this is in fact correct for MR/LMS and earlier BR lamps.. however if you DO want white lamps, they are easily painted if you desire, and we cover the best and easiest way to do this later in this instruction sheet. Our one request here is please NOT hard white! As you can see from the lamp in the picture, white is a very subjective term when it comes to a working oil lamp that darkened from its own heat and was of course always outside in a very mucky atmosphere, so if you must paint them white, off white followed by a dry brushing of muck will be very appropriate!

Each lamp is fitted with our new sub-micro NANO-LEDs and wired with the finest wire we could reasonably use... slightly smaller than 0.1mm in diameter... so small in fact that it can be visible yet unseen if carefully placed and painted to match the background.

Installation does not require any serious work on your locomotives: Because the wire is so small, it needs only the tiniest of holes and even the 4 fine enamel-insulated wires of our dual colour red/white side/guards van lamp will fit easily into a nearly invisible hole made by the smallest drill we could find (#80 or 0.3mm).

Our lamps can easily be installed for use on AC, DC or DCC layouts, and for AC/DC use, we also include here a simple diode drop circuit that will give you constant lighting. Alternately, if you have space in the loco or guards van, we highly recommend our DCCconcepts flicker free for a constant light with zero flicker on AC, DC or DCC layouts.

Details of Flickerfree can be found at http://www.dccconcepts.com.au/index_files/DCCflickerfree.htm

Preparation and Installation guide.

Understanding the lamps:

Carefully remove the lamp from the protective vacuum form and examine it closely.

You will see that the wire is ultra fine and appears bare, however it is enamel insulated led wire (similar to that used on motor windings etc). You will also note that one wire is longer than the other. The long wire is the POSITIVE wire and should be connected to the blue wire if you are using a DCC decoder to control it. In the case of our 2 LED side/guards van lamp, there are two long positive wires and two shorter.

Test and preparation:

Every lamp has been pre-tested before packing as our quality control programme insists on 100% reliability for this product, however if you wish to pre-test it then connect one of the resistors we have supplied to the long (+) wire and connect the resistor to the + terminal of your power supply, then connect the shorter (-) wire to the (-) terminal of your power supply. (You may use any AC, DC or DCC power source between 6 and 18 volts)

- (1) You will note some small light bleed from the bottom of the lamp. When the lamp is dimmed to a properly prototypical level this will become almost zero, however if you are like us you will want it gone totally.

This can be done very easily by adding a small drop of black paint to the hole at the bottom of the lamp. (Let the paint dry properly before taking the next step)

- (2) You will note that the sides of the lens have not been painted.

If possible use an airbrush and give the whole of the lamp a fine coat of black paint. Brushing is fine too of course, however please do not over do it as its very easy to hide the detail in something so small, and too much paint doubles the handle thickness!

There is no need to mask any part of the lens - just paint it all over and we will sort that out in the next step. NOW is the time to add a white top coat and dry brush weather it if that is what you wish to do!

- (3) When the paint is 100% dry, take a fine, flat needle file or some fine “wet and dry” paper glued to an ice-lolly stick or similar and with it held parallel to the face of the lamp, file back the lens to clear the paint. We purposely made the lens slightly over-length to accommodate this filing without making it too short!
- (4) You will now have a perfectly clear lens with a perfectly painted edge. If you wish to totally restore the glassy face of the lens to a gloss, brush it with a little high gloss varnish and allow to dry. The lamp is now ready to install.

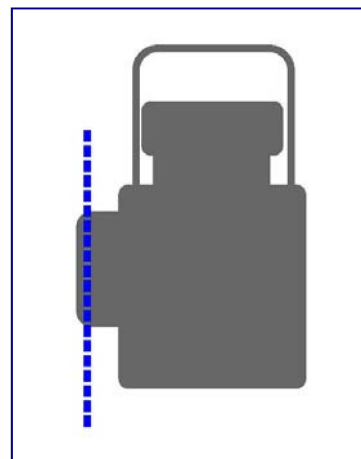

Lamp Positioning on locomotives, coaches and brake vans:

Plan first where the lamps should go. For locomotives there was a defined lamp position for every train type, and these were very strictly enforced - no train or even light loco travelled anywhere without the lamps in place.

Here is a simple chart which covers most railways from the time of the grouping, including BR:

http://www.dccconcepts.com/New_web_images/ADVICE/Loco_Headcodes.jpg

however Southern modelers in particular should refer to specific information as SR used loco headcodes differently. For a truly excellent set of references about SR and related railways headcodes, refer to this link

<http://www.semgonline.com/headcodes/sheadcodes.html>

In addition, a well presented set of information covering each region and different timescales can be found here on the website of the Solihull model railway society. <http://www.solihullmrc.org/>

Preparation and Installation guide.

(a) Locomotive, tender or coach/guards van preparation:

As always refer to the prototype for lamp positions on guards vans or other stock. ... The web should help you with this (or ask us if stuck)

Lamps were positioned on rolling stock or a locomotive or tender by placing them onto a lamp Iron or bracket. This was a usually short vertical peg which fitted into a metal loop on the back of the lamp.

Apart from Southern region loco's, these were positioned as follows:

1x at the upper centre of the smoke-box front.

1x at the centre of the buffer beam a few inches from the front edge.

1x each side of the buffer beam a few inches from the front edge.

This was repeated at the rear of a tank loco or on the rear of a tender.

NOTE: Early Diesel and electric locomotives also had these lamp

brackets for a reasonable period - Its good to get this right so please do check your prototype to be sure you get this right, as it changed over time, class by class.

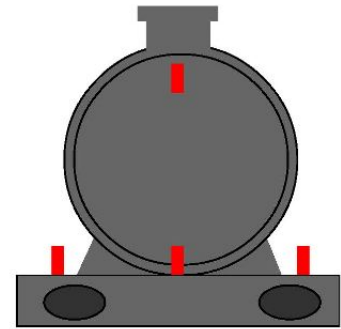

**RED lines
represent the Standard
Lamp Iron Positions**

(b) If your locomotive or stock does NOT already have lamp Irons: (Accurate lamp Irons)

- (1) Look on the web or in reference books and try to find a photograph of where they should be so you get it right first time - After all, there's no point in adding accurately made details in the wrong place, is there!
- (2) Lamp Irons aren't hard to do, so in order to make the loco look really good, please do consider making some lamp Irons from flattened 0.3mm brass wire. To make a realistic Iron, check photo's of the real thing as a guide... the shape is actually an "L", with the foot of the Iron aligned front to back of the loco, and the vertical usually to the front. The front smoke-box lamp iron can have a complex shape, but don't be put off having a go, and anyway, even a simple lamp iron looks better than no iron at all!

***TIP:** If you want to bend up the more complex smoke box irons more easily, take the 0.3mm brass wire and heat it to a cherry red in a gas flame, then quench by dipping the red hot wire into a cup of water. This will anneal the brass, making it easy to flatten, file and bend to complex shapes without breaking.*

***TIP:** Its really hard to place a tiny lamp Iron, so make them all far too long initially, and use the extra length as a handle to hold them by while pacing/soldering or glueing them in place. Once they are firmly fixed, trim to length with sharp cutters and tidy with a file.*

- (3) When the glue is properly dry, carefully trim off the excess length with a pair of fine cutters. And tidy up if needed with a fine file. (Do try to use very little glue as too much looks terrible)
- (4) Having decided where the lamps are going, mark the position for the wiring hole for each lamp (as close as possible to the front of the lamp Iron) with a sharp scribe or needle and carefully drill right through the front footplate or smoke-box front with a 0.3mm (#80) drill.

(c) If your locomotive does NOT already have lamp Irons: (Simple lamp Irons)

- (1) Mark a position for each lamp Iron with the sharp tip of a scribe or needle and using the mark as a guide for the drill, drill 0.3mm right through the buffer beam or smoke-box front.
- (2) Anneal 0.3mm brass wire as above, then then flatten it about 5mm from the end for appx 4mm. Cut this bit off about 10mm above the flat part to give you a good handle while glueing.
- (3) Place in the hole pushing it in until the flat part meets the buffer beam etc. (for simple smoke box Irons, make the flat part longer (say 6mm and bend at the mid point of the flat part, pushing it in so the Iron is quite close to the smoke-box front, as the lamp will need to be close in when fitted)

Continued.....

(5) Solder or fix with glue as invisibly as possible - This is best done from inside or underneath where any excess will be invisible. When glue is totally dry, trim it with sharp cutters and if necessary tidy with a fine file.

(d) If your locomotive already has lamp Irons, or you have already added them:

- (1) Having decided where (on which lamp Irons) the lamps are going to be fixed, mark the position for the wiring hole for each lamp (as close as possible to the front of the lamp Iron) with a sharp scribe or needle and carefully drill right through the front footplate or smoke-box front with a 0.3mm (#80) drill.
- (2) Carefully insert the very fine lamp wires into the hole you have drilled.
- (3) Use a very minimum of glue to hold the lamp against the lamp Iron and prop in place squarely and securely until the glue is dry. As with the lamp Irons, "less is more" when it comes to glueing such small items.
- (4) Once the glue is properly dry, gently smooth the wires against the underside of the buffer beam and route them in a safe position in a path from the front of the loco to where they will connect to the loco wiring.

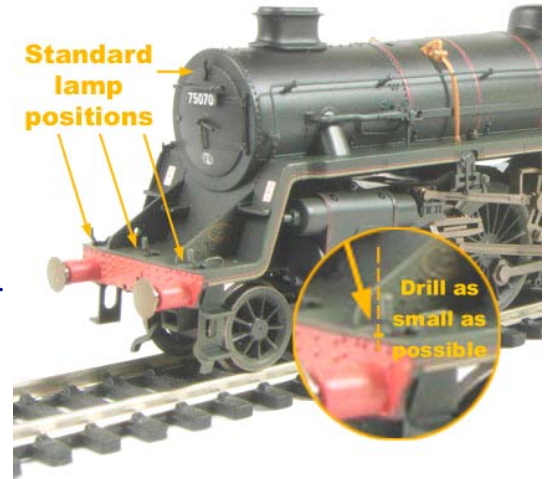

- (5) When you are happy with the routing of the wires, fix them to the body close to the lamp with an appropriate glue - superglue works very well for this. This glueing of the wire to the body close to the lamp prevents wires being pulled off the lamp and protects wires from damage when the body is put back on the chassis.
- (6) Add an appropriate resistor to the longer/positive lead.
- (7) Connect to the loco harness / constant light circuit or DCC decoder and test.

(e) If you are fixing lamps to a guards van, rear coach or the rear of a tender.

Follow all other instructions as for a locomotive. For a guards van, lamps are often in places where wires can be hard to hide but do not worry... the wires are VERY fine and can be glued to the veranda supports in plain view, then painted to match the van livery - If you have routed and fixed them cleanly, they will become invisible.

CONSTANT LIGHTING for those using conventional DC or even 3 rail AC to run their layout.

You too can have realistic constant lighting, and its easy to do too!

Simply install a DCCconcepts "Flickerfree" unit in your loco and you will have constant intensity lighting for your lamps - Even better, once the loco has run for a minute the lamps will stay on, even when the loco is stopped!

Flickerfree is simple to install, and just needs its power input wires connected to the track pickups of your locomotive. Wire all white LEDs in parallel and add a single resistor (anywhere from 1 to perhaps 20k ohm depending on your preferred light level) in series with one of the lamps positive leads and connect that to the red output wire of flickerfree.

Connect the lamps negative leads to the black output wire of flickerfree and you are ready to go.

You can use the same approach for red lamps too, however the resistor value will probably be different to that chosen for white LEDs. Note that red and white LEDs can both be connected to the same Flickerfree, however the red and white lamp circuits must each have their own resistor and be wired in parallel with each other.

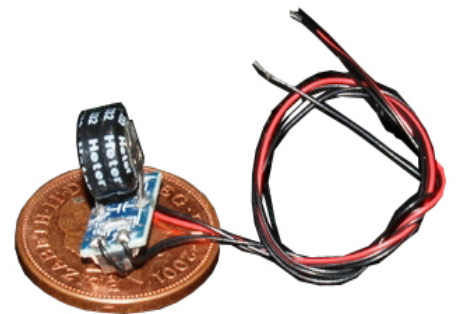

Continued.....

A Simple wiring Guide

Every LED must have a resistor in series with one wire of the LED.

“Best practice” says to place it in the positive wire (The blue common wire on a DCC decoder function), however in reality it is not critical.

You may use ONE resistor for two lamps of the same colour, however you should use a separate resistor for red and white lamps, especially if they will be on together, as each LED colour has a different basic power need, and if you try to share a circuit with two different colours, one will not turn on as the other will hog all of the power! This is easy to arrange - Just connect two resistors to the blue wire in parallel, and connect one colour to each resistor.

We pack every 6-pack of lamps with 6 each of three different value 1/8 watt metal film resistors. Using higher value resistors will give a lower brightness. We have included the selection because each modeller will have his or her own preference. We have chosen this type as it is physically very small and will easily fit inside the small heat-shrink tubing used for loco wiring (If you need heat-shrink, you will find it here, about 1/3 down the web page):

http://www.dccconcepts.com/index_files/DCCinstallaids.htm Using higher values will give a lower brightness. Experiment a little.

Resistors are identified by coloured bands. This chart will help you to identify the value of each resistor packed with your lamps.

Resistor Identification

The end with more bands should point left when reading colors.

Color	1 st Band	2 nd Band	3 rd Band	Multiplier	Tolerance
Black	0	0	0	x 1 Ω	
Brown	1	1	1	x 10 Ω	+/- 1%
Red	2	2	2	x 100 Ω	+/- 2%
Orange	3	3	3	x 1K Ω	
Yellow	4	4	4	x 10K Ω	
Green	5	5	5	x 100K Ω	+/- 5%
Blue	6	6	6	x 1M Ω	+/- .25%
Violet	7	7	7	x 10M Ω	+/- .1%
Grey	8	8	8		+/- .05%
White	9	9	9		
Gold				x .1 Ω	+/- 5%
Silver				x .01 Ω	+/- 10%

CONNECTING LAMPS TO A DCC DECODER

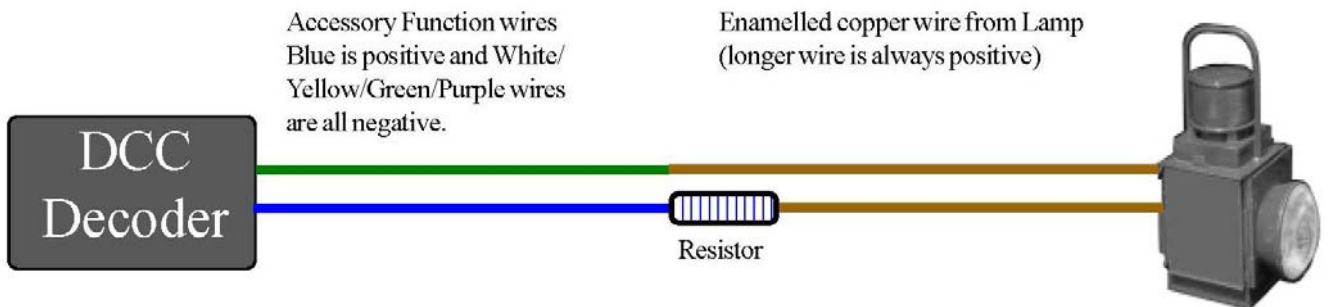

With a decoder, you can also increase dimming by changing the voltage output level of the function you are using - check your decoder instructions for how to do this

USING FLICKER FREE FOR CONSTANT LIGHTING ON DC LOCO'S

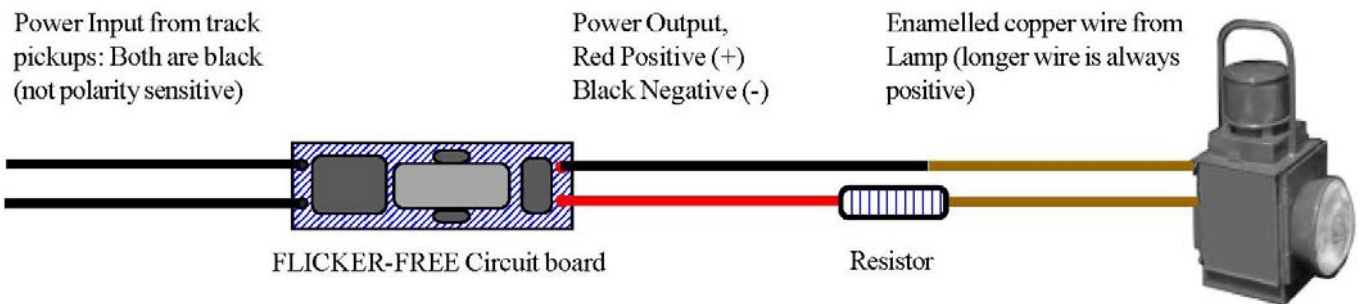

Still have questions? Please don't hesitate to ask. Our email address is questions@DCCconcepts.com