

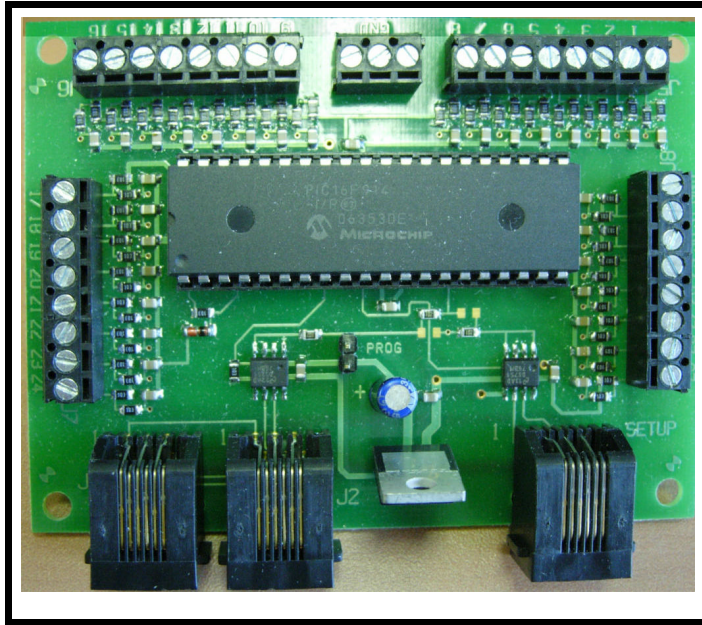

# Mini-Panel

Accy and Macro Controller



Dimensions: 3.20" x 2.70" (81 x 69 mm)

Revision 1.00

**\$49.95**

**Build the kind of control panels you've always wanted  
without complicated wiring!**

- ✍ Use one button to control multiple switches or macros on your NCE DCC
- ✍ Up to 30 pushbuttons, toggle switches, block detectors, etc. can be connected for control of turnouts, signals and other devices
- ✍ Easy programming, just plug in a ProCab
- ✍ Simple hook up, one Cab Bus connection and 2 wires for each pushbutton or other input device
- ✍ Can be used to perform simple automatic train control and other layout automation tasks

**05240230**  
**05240230**

This book, schematics and artwork copyright 2008  
NCE Corporation 82 East Main Street Webster, NY 14580

## Description of Mini-Panel

The mini-panel is primarily intended to make it easy to build control panels for yards, towns, interlockings and other layout applications. A secondary use of the panel is to provide rudimentary automation of trains or control of signals. For more complex automation or signal operation the *Macro*-panel has more comprehensive implementation of these secondary features and more memory for command storage.

The mini panel has 30 inputs that can be connected to pushbuttons, toggle switches, block detectors, etc. for the purpose of issuing accessory, macro or locomotive control commands. A thirty-first input is provided to act as a panel reset. Activation of an input can initiate sending a string of DCC commands through the track to turnouts, locomotives, signals or other DCC controlled devices. Inputs are activated by connecting them to the mini panel "GROUND". This makes the mini panel compatible with all pushbutton/toggle switches and most block detectors.

The mini-panel communicates with the command station via the cab bus and uses one cab bus address.

Setup (programming) of the mini-panel is accomplished by plugging a ProCab or NCE USB adapter into the "setup" jack. If USB is used the mini-panel memory is accessed via binary CV read and write commands (page or direct mode). USB jumpers should be set for PowerCab v1.28 or ALL SYS. CV7 and CV8 return the manufacturer number and version of the Mini Panel as with a decoder when used with the USB interface.

## Installation Notes:

The mini panel runs off Cab Bus power (nominal 12V DC) and draws about 90mA of current, slightly less than a ProCab. NOTE: When used with the PowerCab use the mini panel default address of 3.

## Wiring:

See the diagram below for sample wiring ideas.

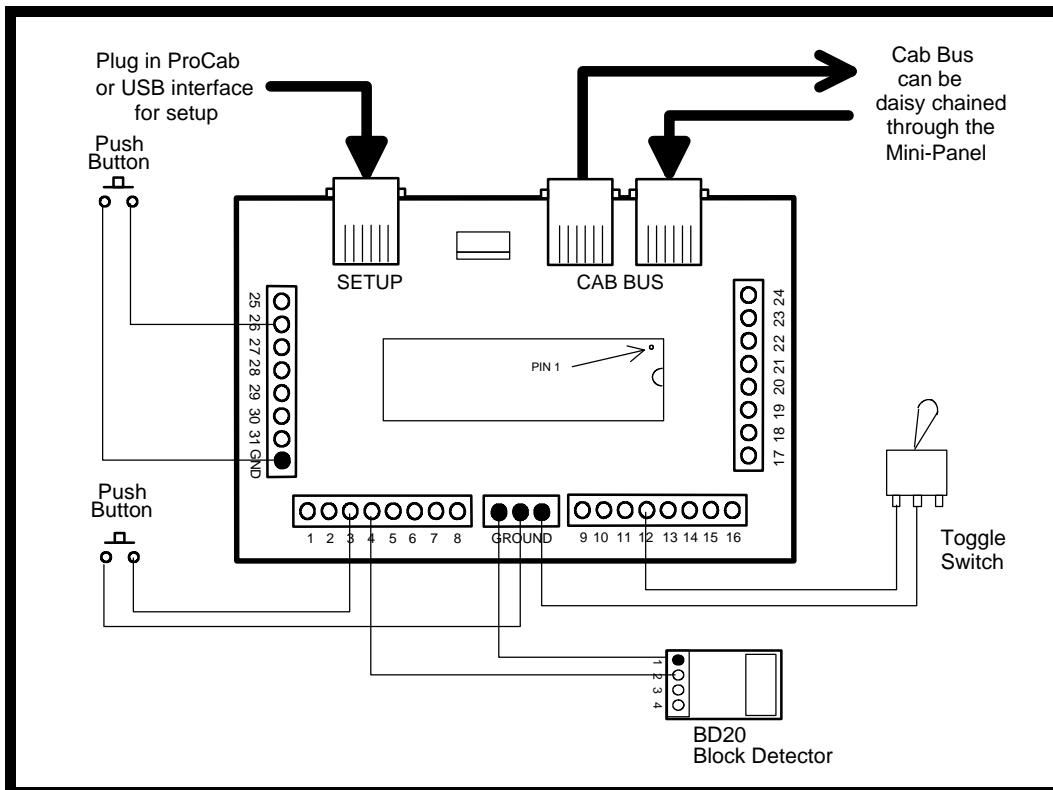

## Simple control panel example:

Below is an example of a control panel for a simple yard with 3 tracks off the mainline. We only need 4 pushbuttons to select the various tracks in the yard. We designated the yard as tracks 2, 3 and 4 with track 1 the main line.

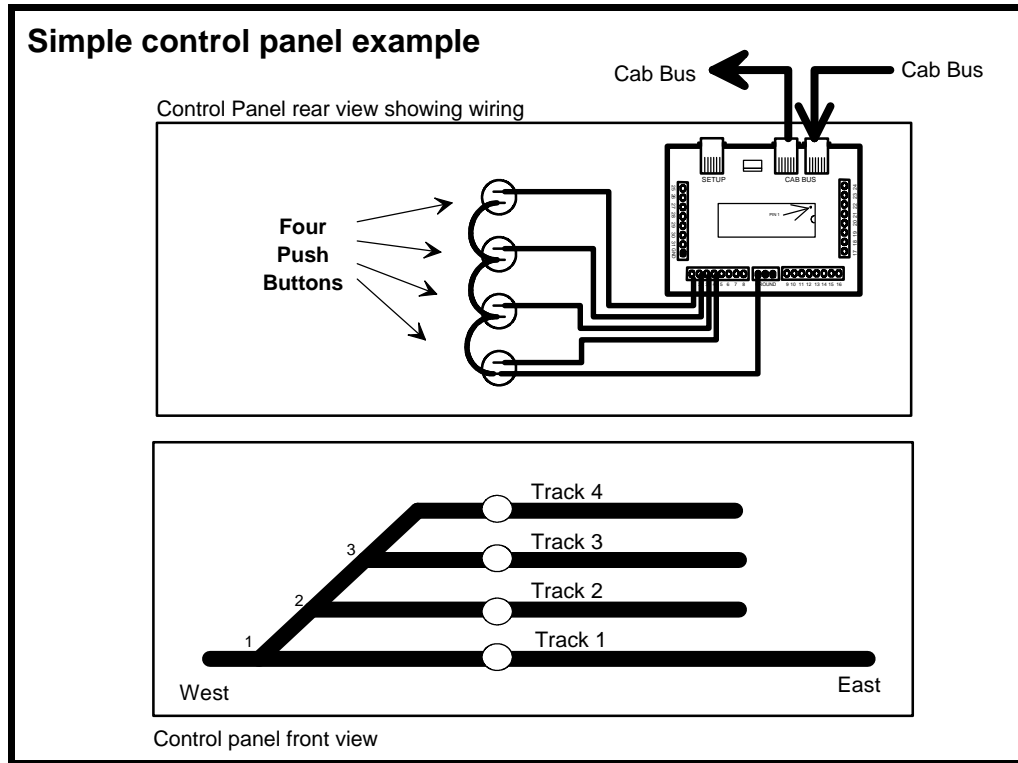

Wiring of the mini panel for this example is quite easy. Each pushbutton has two terminals. We connect one terminal from each button together and then tie it to one of the "GND" terminals of the Mini Panel. Then we tie the remaining terminal from each button to a separate input terminal of the Mini Panel. The last connection(s) to be made is the Cab Bus connection. There are two Cab Bus connectors to make it easy to 'daisy chain' the Cab Bus through the panel and on to other Cab Bus connection on the layout. All that is left is to setup the Mini Panel to send the commands for correct alignment of the yard switches when each button is pushed.

## Control panel setup example

In the example there are three DCC controlled turnouts with accessory addresses of 1, 2 and 3 as noted in small text on the panel drawing above.

## What we want to accomplish:

Press the button 1 to align the turnouts for track 1, press 2 to align for track 2, 3 for track 3 and so on.

Pressing button 1 will need to send the following command

Accessory 1 (turnout 1) to the Normal (straight position)

Button 2 will need to send

Accessory 1 to Reverse (diverging) position

Accessory 2 to Reverse (diverging)

Button 3 will need to send

Accessory 1 to Reverse (diverging)

Accessory 2 to Normal (straight)

Accessory 3 to Reverse (diverging)

Button 4 will need to send

Accessory 1 to Reverse (diverging)

Accessory 2 to Normal (straight)

Accessory 3 to Normal (straight)

To set up the Mini Panel plug a ProCab into the "SETUP" jack of the Mini Panel, make sure the Cab Bus is connected from the Mini Panel to the NCE DCC system and turn the power for the system on.

The mini panel will detect the presence of the ProCab and you should see an opening LCD display of:

```
NCE MI NI - PANEL
VERSI ON 1. 00
```

Press ENTER on the ProCab to get the main display for panel setup

```
1=SETUP 2=MACRO
3=TEST OPERATI ON
```

We want to setup the panel so press "1" to enter setup mode, this will present the display screen as below

```
SETUP MI NI PANEL
1=I NPUT 2=CONFIG
```

Press "1" to setup an INPUT.

```
SETUP I NPUT MENU
I NPUT NUMBER: 01
```

We will start programming the inputs with input number 1. Type "1" followed by "ENTER" to program input number 1

```
SETUP I NPUT MENU
STEP NUMBER: 1
```

Normally when setting up an input we start with step number 1. We want to start programming at step 1 so just press ENTER to accept that step. Commands will be sent from the Mini Panel in order of their step number until an 'empty' step is encountered or four steps are completed.

```
I NP: 01 STEP: 1
1=ACCY 2=MACRO
```

At this point we're ready to tell the mini panel exactly which command to send when button 1 is pushed. Press "1" to send an accessory command.

```
I NP: 01 STEP: 1
ACCY NUMBER:
```

Type the accessory number "1" followed by "ENTER". Allowable NMRA accessory addresses are 1-2044. Accessory number 2044 is the broadcast address for accessories. There is no accessory address 0.

```
I NP: 01 STEP: 1
1=NORM 2=REV
```

Press "1" to send the accessory command for Normal when button 1 is pressed.

```
I NP: 01 STEP: 2
1=ACCY 2=MACRO
```

Note that the step number has increased to 2 indicating the last command has been accepted and the Mini Panel is ready for the next command for this input. We don't need any more commands for this input so press "PROG/ESC" to return to the main menu.

**1=SETUP 2=MACRO  
3=TEST OPERATI ON**

Let's review the command that has just been programmed. Press "2" to review.

**1=SETUP 2=REVI EW  
REVI EW I NPUT:**

Type "1" and press "ENTER" to review the command sent by input number 1

**I NP: 01 STEP: 1  
ACCY: 001 NORM**

The LCD no displays the accessory number (1) that we entered and the turnout position (Normal). Press "ENTER" to see the next step for this input

**I NP: 01 STEP: 2  
- - END- -**

The display now indicates that there are no more entries programmed into this string. At this point you may continue pressing "ENTER" to cycle up through all the commands programmed if you wish. The Input and step numbers will be displayed as well as a description of the command for that step. Press "PROG/ESC" to return to the main menu.

**1=SETUP 2=MACRO  
3=TEST OPERATI ON**

At this point we have programmed and reviewed the command(s) that will be sent when input number 1 is grounded. The command can be tested by pressing "3".

**TESTI NG  
I NPUT NUMBER: 01**

Press "1" followed by "ENTER" to test input 1. The command string associated with input number 1 will be sent.

**1=SETUP 2=MACRO  
3=TEST OPERATI ON**

Putting the Mini Panel into test mode will also allow testing of any input by grounding that input number. Pressing any button on the ProCab will return the Mini Panel to setup mode.

**Finishing programing:**

At this point we have programmed, reviewed and tested the command(s) that will be sent when input number 1 is grounded. In a similar manner we can program the commands for inputs 2,3 and 4 using the proper accessory or macro commands.

**MENU NAVIGATION CHART**

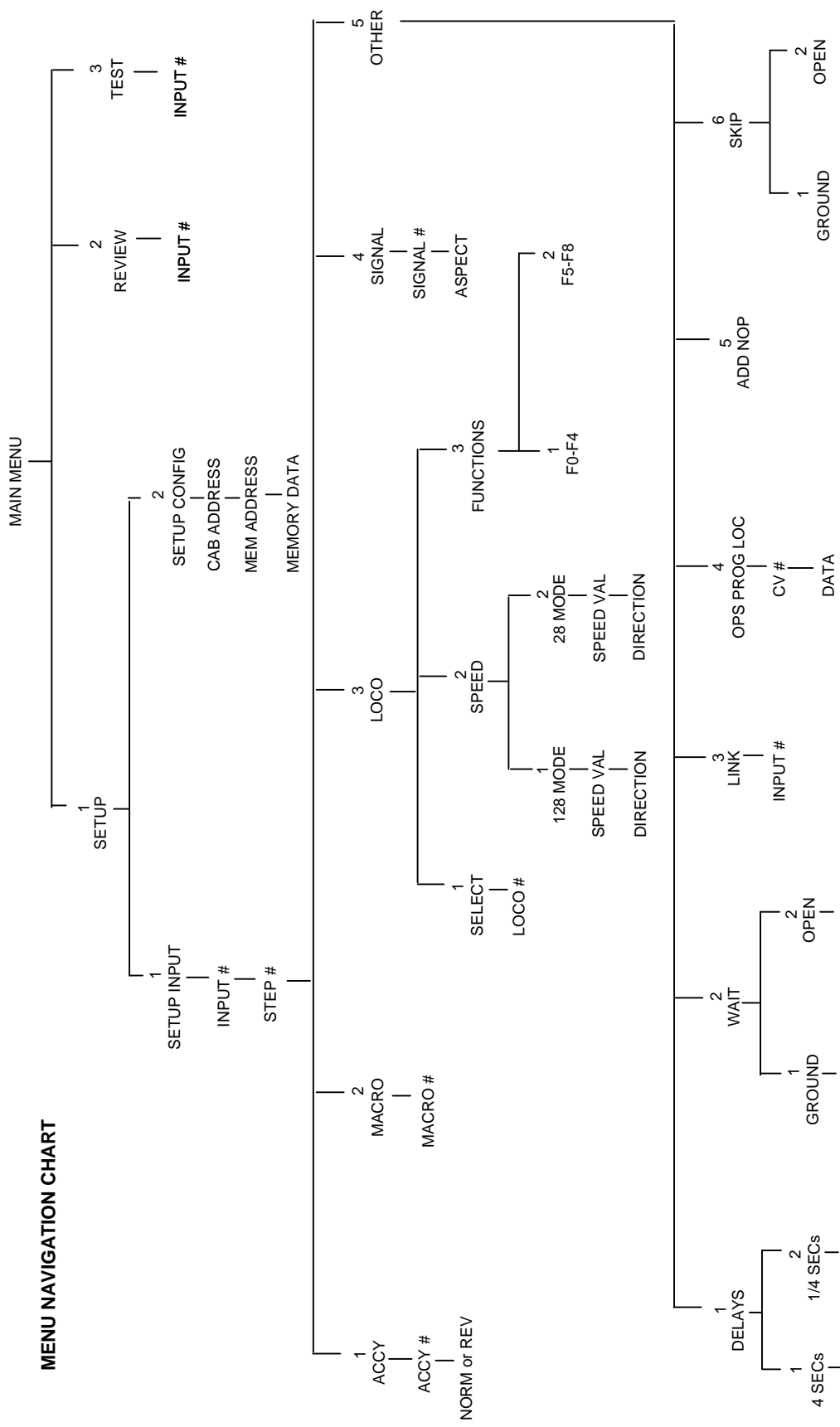

## Command Descriptions:

The following commands can be setup through the ProCab user interface and sent by the Mini Panel:

### Accessory/Macro commands

- ✍ Accessory Command - all NMRA standard accessory addresses (1-2044) can be sent via the accessory command
- ✍ Macro command - all NCE macro numbers (0-255) can be sent via the Macro command

### Locomotive commands

Speed and functions may be controlled

- ✍ Select loco - A locomotive must be selected before any commands can be sent to that loco. Any NMRA standard locomotive address (up to 9999) may be selected. Short addresses fro 1-127 and long addresses 0-9999 are all valid and are entered in the same manner as they are selected in normal operations with a Pro/Power Cab. A leading zero before and address in the range of 1-127 indicates a long address. Once a loco address is selected all speed, function and Ops programing commands will be sent to that address unless another address is selected.
- ✍ Speed commands - Both 28 and 128 speed mode commands can be sent. Once the speed is entered the direction can be changed by pushing the "DIRECTION" button.
- ✍ Function commands - Function commands for F0-F8 can be sent. Due to the way the NMRA has defined function operation, functions are not controlled individually but are controlled in groups of four or five (or eight) at once. The state of F0-F4 (function group 1) must be sent as one command while the state of F5-F8 (function group 2) is as a different command. When you choose the 'Function' option from the Loco commands Menu you must choose which function group you want to control

**ENTER FUNC GROUP**  
**1=F0- F4 2=F5- F8**

Once the group is selected you can select which functions in that group are to be on or off.

**PRESS F NUMBER**  
**DIGITS 0- 4: - - - - -**

In the case of function group 1 (LCD display above) pressing a digit of 0-4 will toggle that function on/off. If a digit is displayed the function will be on of a dash ("-") is displayed the function will be off.

**PRESS F NUMBER**  
**DIGITS 0- 4: 0- 23-**

In the display above F0 (headlight),F2 and F3 will be on and F1, F4 will be off.

### Signal commands

- ✍ Signal Command - all NMRA standard signal addresses (1-2044) can be controlled via the signal command. Aspects are limited to the first 8 aspects (0-7). The signal commands are the NMRA standard signal commands using NMRA standard signal control packets.

## Other commands

There are 6 groups of 'other' commands executed by the Mini Panel. These commands do not result in a DCC command being sent but control the flow of the commands from the Mini Panel.

- ✍ Delays - Two different delay commands can be used. These commands will cause the Mini Panel to delay execution of the next command in increments of ¼ second (up to 64 seconds total delay) or increments of 4 seconds (up to 1020 seconds total delay). A delay of 0 will cause the next command to be executed immediately. Use of this command causes all operation of the Mini Panel to stop while the command is in progress.
- ✍ Wait - There are two Wait commands, one command waits for a indicated input to be grounded, the other waits for the indicated input to become ungrounded (open). Use of this command causes all operation of the Mini Panel to stop while the command is in progress.
- ✍ Link - Use of this command will transfer operation to the string of four commands associated with another input.
- ✍ Skip - There are two commands that can be used to make a decision based on the status of an input. These commands check the status of a user indicated input and either execute the next command in the string or skip over that command and execute the following command. One skip command skips if the indicated input is grounded the other skips if the input is ungrounded (open). These are very powerful commands allowing the Mini Panel to execute different commands based on the state of an input at the time the skip command is executed.
- ✍ Nop - The No-Operation command. This command can be used as a place holder for future commands. When the Mini panel encounters this command in the command string it will be ignored and the next command will be executed.
- ✍ CV Program - Allows programming of locomotive CVs in Ops mode. OPs mode programming requires 3 steps:
  - set loco address (long or short)
  - set CV number
  - set CV dataWhen the data command is executed an Ops programming command will be issued out over the cab bus to the track.

## Technical stuff:

### Linking command strings

Inputs cannot normally be "decoupled" from their command string. If you link to the command string of an input that is connected to something that may activate that input, the commands for that input will be executed when the input is grounded. In some circumstances this may be desirable allowing portions of larger, longer command strings to be used. Normally you will want to leave linked inputs electrically unconnected.

### Disabling inputs

Memory location 4 can be programmed with the input number above which electrical status of those inputs will be ignored. Grounding one of those inputs will not result in execution of its command string. The input will still be sampled by any 0xc6 commands that look at input status.

### Continuous Memory

You can write fairly long automation sequences by constructing strings of 3 commands followed by a link to another string. This is inefficient in that only three out of four command locations in memory actually control anything.

Memory location 3 can be programmed with an input number above which memory will be considered continuous. This means above that input number commands will continue to flow across each four command boundary and be executed until a terminating command of 0x00,0x00 is encountered.

Remember that if any of those higher number inputs are grounded the associated commands starting at that input number will still be executed (unless memory location 4 is programmed) and run until a termination command is encountered.

### **Interrupting Wait Commands**

Wait commands will loop until the input condition is met. No other operations of the mini panel will be performed while waiting so the panel will appear dead. It is quite possible that situations on the layout will occur that upset the flow of your automation 'program'. Imagine that the program is waiting for a loco to get to a certain block and a derailment occurs causing the train to stop. The loco is replaced on the track but on a parallel track resulting in the loco never getting to the block that the program is expecting to be occupied. The mini panel will wait forever appearing to be unresponsive. You can utilize an unused input of the mini-panel as an 'interrupt' to break the mini panel out of this wait forever loop and continue normal operations. Program memory location 5 with the input number you want to use as the interrupt. By connection a pushbutton to this input you can provide a recovery mechanism without resetting the entire panel, losing turnout positions, signal aspects or loco function states.

### **OPs programming command**

OPs mode programming requires 3 steps:

- set loco address (long or short)
- set CV number
- set CV data

When the data is set the programming command will be issued out over the cab bus to the track. If the loco address has already been set in a previous command that address will be used. The same applies to the CV number. You can use this to your advantage to program momentum using the (3 required steps) into a locomotive then later just programming a new momentum value using only the set CV data command.

### **Command string terminator**

When the mini panel encounters the command 0x00,0x00 it is considered the command string terminator. Any commands following the terminator in the string will not be executed.

### **Input scanning**

The inputs of the Mini-panel are scanned in numerical order. Inputs are sampled in groups of 8 and stored in temporary memory. This group is then scanned for active inputs. An input at or near ground potential is considered active. When an input is transitions from open (high due to 5v pull-up resistor) to ground (low) it will trigger execution of a string of up to four commands associated with that input. Transitions from low to high are ignored and no action is performed.

The lowest numbered active input of the group of eight is acted upon first. The command string associated with that input will be executed. Execution of the command string will continue until a command of 0x00,0x00 is encountered or until 4 commands are executed.

One exception to the four command limit is the "link" command that transfers execution to another input command string. This allows borrowing the memory location from other (possibly) unused inputs to create longer strings of commands. The memory space for the unused input can be used by another command string.

Once a command string has completed execution the next active input will be located and its command string executed.

After a group of 8 inputs is scanned and any active inputs are serviced the next group of 8 inputs will be sampled.

Inputs are captured eight at a time and actions generated by those 8 inputs are completed before capturing the next higher group of eight. If an input of one group of 8 initiates a long string of commands (see linking below) that will take a significant period

of time is it possible to miss momentarily activated inputs. This is not a problem for typical applications with quick acting command strings such those used with a control panel that just issues accessory/macro commands. The problem may occur in layout automation applications that require long periods of time waiting for a loco to enter a block or delays used for stopping at a station. In these cases you must carefully consider the series of event that may be happening and how commands are strung together.

### **USB interface**

When using the NCE USB interface memory locations 1-255 can be read or written using programming track direct mode binary commands 0xa8 and 0xa9. It is necessary to put the USB interface into program track mode with the 0x9e command before attempting programming other wise you will just get the "not in program track mode" response from the USB interface. This will allow you to test the commands you just programmed without having to disconnect the USB interface. You cannot read memory location 0 (Cab Bus address). Memory locations 6 (CV7) and 7 (CV8) correspond to decoder CVs 7 and 8 allowing you to determine the Mini Panel make and software version. Mini panel software versions start at 200 (decimal) and the manufacturer is 11 decimal (NCE). You may still write to these memory locations but not read them through the USB interface. They are trapped by the mini panel software when the USB is used for reading with the manufacturer and version substituted for the actual values in memory. You can read them by plugging a ProCab into the SETUP port.

When using Decoder Pro for programming select:

- Service mode programming
- Comprehensive Programmer format
- NMRA
- Raw CVs 1-255

Click on "READ" for CV1. Due to multiple layers of buffering between the USB and Mini Panel the first CV read will fail but you should get valid reads and writes from that point on. Using Direct Byte mode is slightly faster than Paged mode.

When finished programming you can put the Mini Panel back into operational mode with the 0xa6 (Write register) command. Any register and value is OK. The panel is just looking for any Write Register command

## Command format of the Mini Panel

The table below describes the hex bytes stored in the memory locations for each command

Hex	1st Byte	2nd Byte	Command
0x00	0000 0000	0000 0000	command string terminator - stop execution
00->07	0000 0aaa	aaaa aaaa	accessory on(N) 1->2044, addr 0 not valid
08->0f	0000 1aaa	aaaa aaaa	accessory off(R) 1->2044, addr 0 not valid
40->7f	01nn naaa	aaaa aaaa	signal 1-2044 aspect 0-7, addr 0 not valid
80->b7	10aa aaaa	aaaa aaaa	set long loco address 0-10239
b8-bb	1011 10nn	nnnn nnnn	set OPs CV num 1-1024 (set loco/accy addr 1st)
bc	1011 1100	dddd dddd	set OPs loco CV data (set CV number first)
bd	1011 1101	dddd dddd	set OPs accy CV data (set CV number first)
be	1011 1110	dddd dddd	set OPs signal CV data (set CV number first)
bf	1011 1111	nnnn nnnn	delay in 4 second increments
c0	1100 0000	0sss ssss	stored loco 128 speed reverse
c0	1100 0000	1sss ssss	stored loco 128 speed forward
c1	1100 0001	000s ssss	stored loco 28 speed reverse (0-28 valid)
c1	1100 0001	001s ssss	stored loco 28 speed forward (0-28 valid)
c1	1100 0001	010f ffff	function group 1 f0, f4, f3, f2, f1
c1	1100 0001	0110 ffff	function group 2 f8, f7, f6, f5
c1	1100 0001	0111 ffff	function group 3 f12, f11, f10, f9
c1	1100 0001	1aaa aaaa	set short loco address
c2	1100 0010	ffff ffff	f20->f13
c3	1100 0011	ffff ffff	f28->f21
c4	1100 0011	nnnn nnnn	loco detected in block 0-255
c5	1100 0101	nnnn nnnn	delay in 1/4 second increments
c6	1100 0110	000n nnnn	wait until input nnnnn active, 0 not valid
c6	1100 0110	001n nnnn	wait until input nnnnn not active, 0 not valid
c6	1100 0110	010n nnnn	link to execute commands for input nnnnn
c6	1100 0110	011x xxxx	unused
c6	1100 0110	100n nnnn	if input nnnnn active skip the next command
c6	1100 0110	101n nnnn	if input nnnnn not active skip the next command
c6	1100 0110	11xx xxxx	not used
c7	1100 0111	nnnn nnnn	macro 0-255
c8-cf	1100 1aaa	aaaa aaaa	set accessory/signal address 1-2044
d0-fe	---- ----	---- ----	unused
ff	1111 1111	1111 1111	nop - no-operation, just execute next command

Key:

a - address bit, f - function bit, n - number, s - speed data, x - undefined

Notes:

Commands bf and c5 block reading/execution of **all** inputs until time expires

The wait commands of c6 block reading of **all other** inputs until condition is met

The "skip" commands of c6 work in "real time" (right now) and do not wait or block other commands

Once the loco address is set all subsequent locomotive commands will be sent to that address.

Once the accy or signal address is set all subsequent OPs programming commands will be sent to that address

Due to memory limitations the 0xbd,0xbe,0xc2, 0xc3, 0xc8 and 0xc6 function group 3 commands are not available through the ProCab setup interface. They are available for use through the USB interface.



**Default values for memory locations**

Location 0 - 3 Cab bus address, 2-63 are OK

Location 1 - 5 Debounce timer (normally doesn't ever need change)

Location 2 - 0 Clear all 8 memory locations for an input when programming 1=don't

Location 3 - 0 Input number at/above which command string memory is continuous

Location 4 - 0 Input number at/above which commands will not execute if input active

Location 5 - 0 Input number than can be used to interrupt "wait" commands

Location 6 - Unused (Software version 201 when read via USB - CV7)

Location 7 - Unused (Manufacturer 11 when read via USB - CV8)

Locations 8 through 255 - 0

**Warning: This product contains chemicals known to the State of California to cause cancer, birth defects or other reproductive harm.**

**Warranty**

This product is fully factory tested and warranted against manufacturing defects for a period of 1 year. As the circumstances under which this product is installed can not be controlled, failure due to installation problems can not be warranted. This includes misuse, miswiring, operation under loads or voltages beyond the design range of the product.

For warranty or non-warranty repair/replacement send the product (an any payment, if required) to:

**NCE Warranty Center**

**82 East Main St.**

**Webster, New York 14580**

**05240230**

**05240230**

The terms Silent Running, Power Pro, PowerCab , ProCab, Switch-It the NCE logo with "Power of DCC" slogan are trademarks of NCE Corporation. The distinctive shape of the ProCab when used with a thumbwheel speed control and LCD display is a trademark of NCE Corporation.