

WIRING DIAGRAM

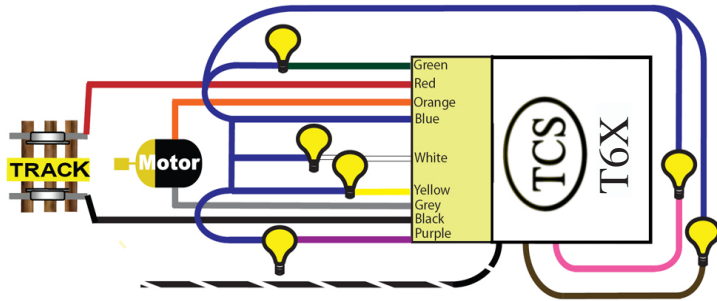

The Black with White stripe wire is for connecting to a VR1.5. The VR1.5 is used to power 1.5 volt bulbs without the need for voltage dropping resistors. The VR1.5 is made by Train Control Systems. See your TCS dealer or visit us online for more information about the VR1.5. If you are not going to be using the black with white wire it can be coiled up or cut off. Make sure the wire does not touch against any metal objects.

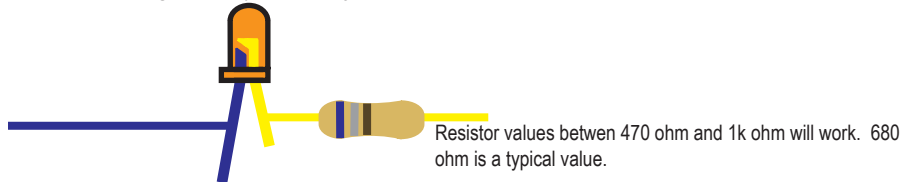

If you plan on using LED's one resistor must be in series with each LED. Being that LED's are diodes they must be wired in with their positive lead (long LED leg) connected to the positive (blue wire), and their negative lead (short LED lead, flat LED edge) to the negative function wire (yellow or white wire).

PROGRAMMING OTHER FEATURES: Decoder Lock, Variable Momentum, Button Control of the motor, Loadable Speed Tables, Modifiable Momentary Pulse, Mars, Gyra and Rotary Beacon Light and Function Remapping. If you wish to use them, see [Additional Programming Guide](http://www.tcsdcc.com) at www.tcsdcc.com or get a copy at your Dealer.

WARRANTY PROCEDURE: All decoders are covered by a one year goof proof, no questions asked warranty. **Please return in a padded envelope or small box.**

1. Register the decoder(s) on our website at www.tcsdcc.com.
2. Print out a copy of the Warranty Registration and include it in the padded envelope with the decoder(s).
3. Return decoder(s) directly to TCS. Train Control Systems
PO Box 341
Blooming Glen, PA 18911

Compatible with NMRA DCC standards. Made by **TCS** in the USA.
© Copyright Train Control Systems 2004-2008

Train Control Systems
P.O. Box 341
845 Blooming Glen Rd.
Blooming Glen, PA 18911



Phone 215-453-9145
Fax 215-257-0735
Email tcs@tcsdcc.com
Web www.tcsdcc.com

1026

TRAIN CONTROL SYSTEMS

NEW

Now Featuring
**Back EMF /
Load Compensation**

\$27.95 US
MSRP



T6X

A powerful decoder for HO scale with a 9 pin harness and six 100mA function outputs. Plus a decoder ground connection for use with an external 1.5v power supply. Provides 1.3 amp continuous and 2 amp peak draw.

Dimensions .956"x.655"x.207" or 24.28mm x 16.63mm x 5.25mm

- **Back EMF Load Compensation** for superior slow speed control even with heavy loads.
- **Quiet Drive** creates **SUPER QUIET** engine performance.
- **Autodetect** for realistic throttle response when using **DC power**.
- **Dimmed Brightness** of bulbs or LEDs is **adjustable**.
- **Dither** is the ultimate in **DCC control** thru the entire speed range.
- **Variable Momentum** lets you make **custom acceleration curves**.
- **Factory Reset** is faster and easier to reset to the default settings.
- **Brake on DC** stops the train with deceleration when in a **DC block**, maintains lighting, then accelerates when DCC returns.
- **Mars, Gyra, Rotary Beacon, Blinking Ditch Lights and Momentary Pulse** are adjustable.
- **Decoder Lock** for programming **same address decoders** independently.
- **Button Control of the Motor Circuit:** for a smoke unit, high speed switching, or a variable brightness light up to 1.2 amps
- **Function Remapping:** 13 buttons for most lights, 7 buttons for operations.
- **OPS Mode Programming** allows on the main track programming.
- **All Program Modes** are supported allowing use with any controller.
- **Basic and Advanced** Consisting for use with any controller.
- **Standard 2 Digit or Extended 4 Digit Addressing.**
- **User Loadable Speed Tables** for custom speed curves.
- **14 or 28 / 128 Speed Step Control** operating at 256 speed steps.
- **Additional lighting features** not listed above include Random Flicker, Single & Double Strobe, and Constant Dim light.



**Our Famous GOOF PROOF NO
Questions Asked Warranty**

WORKSHEET INSTRUCTIONS

- A blank outlined box is provided by each CV number. This is so you can preplan your decoder and have a record of your choices.
- In many cases you are recording a single value such as an address, a rate, or a limit.
- In some cases you are choosing more than one value such as actions, functions, or buttons. Each of these will have a value. Add the values of those you want active and enter that sum in the blank box.
- The other box by the CV number is the factory set value. If it is shaded, it can be reset with **Factory Reset**.

BASIC CONFIGURATION

Circle the values by all of the changes you want to make.

1	A	0	1	Reverse the direction the engine runs.
	B	2	-2	Use 14 Speed Steps instead of 28/128.
	C	4	-4	Disable analog (DC) operation.
	D	0	16	Make the Loadable Speed Tables active.
	E	0	32	Make the decoder address 128 or higher.
CV 29	6			Adjust the Default Value by the values you have circled.

ADDRESSING

2 Digit Address

Use if the address is 127 or less.

2	CV 1	3		Record your choice here.
---	------	---	--	--------------------------

4 Digit Address

Make sure Table 1 "E" = 32.

3				Your command station will assign the values of CV 17 and CV18
CV 17	0			← Record your four digit address here
CV 18	0			

For more information about CV 17 and 18 visit our web entry on this topic at: http://www.tcsdcc.com/faq/four_digit_addressing.htm

Consist Address

If this is greater than 0, the regular address is unalterable.

4				Add 128 to reverse the loco when in consist. Some systems only!
CV 19	0			Use a 2 digit address when in a consist (Multiple units).

MOTOR CONTROL

Speed Graph

1 volt = 18

0 produces straight line acceleration.

6	CV 2	0		Start Volts	Set the voltage when the throttle is first applied.
	CV 6	0		Mid Volts	Set the voltage when the throttle is at midpoint.
	CV 5	0		Top Volts	Set the voltage when the throttle is at full speed.

Momentum

The effect of engines starting and stopping heavy loads.

7	CV 3	0		Acceleration	Larger values add time to each speed step.
	CV 4	0		Deceleration	Larger values add time to each speed step.
	CV 23	0		*Acceleration Adjustment when in Consist	
	CV 24	0		*Deceleration Adjustment when in Consist	

*Values above 128 increase the adjustment * Values below 128 decrease the adjustment

Dither

Dither provides the ultimate in speed control throughout the speed range.

10	If there isn't movement at 2%, increase CV 57 by 5 until you have movement of the flywheel. To fine tune the speed, change CV 56 by 1 until it is running as desired.				
	CV 56	3		Dither Frequency	The highest frequency = 1.
	CV 57	10		Dither Voltage	The lowest voltage = 1.

NOTE: Both CV 56 and CV 57 must be greater than 0 for Dither to be active.

Back EMF, Rule 17 Dimming Options and Opposite Dim Control

If BEMF is enabled Dither is disabled. If BEMF is disabled Dither is automatically enabled based on the values of CV56 and CV57. To adjust dither set CV57 to a recommended value of 15, if there isn't movement at 2% throttle setting, increase CV57 by 5 until you have movement of the flywheel. To fine tune the speed, change CV 56 by 1 until it is running as desired.

Even number OR 0= BEMF OFF Odd number = BEMF ON

13	BEMF disabled = 0		BEMF enabled = 1		BEMF button control = 3		Dims when stopped = 16	
	To turn on BEMF and function button control of it, put 3 into CV 61						Opposite light is dimmed = 32	
	CV 61	1		BEMF and Dimming Control		BEMF+Stopped + Opposite dim = 49		
	CV 136	2		Function button control of BEMF		Bits 0-7 designates buttons 5-12		
	CV 64	15		Dimmed Brightness		(2 - 6 for LEDs, 12 - 18 for Bulbs)		
CV 10	0		BEMF Cut Out		For more information go to www.tcsdcc.com/BEMF.pdf			

Light Function Wires

Choose a value.

11	CV	Value	Wire Color	Light Effect	Choose a value.		
					fwd	rev	both
	CV 49	0	White Wire-F0	Constant Bright Light	0	16	32
	CV 50	16	Yellow Wire-F0	Random Flicker (fire box)	1	17	33
	CV 51	32	Green Wire-F1	Mars Light	2	18	34
	CV 52	32	Purple Wire-F2	Flashing Light	3	19	35
	CV 53	32	Brown Wire-F3	Single Pulse Strobe	4	20	36
	CV 54	32	Pink Wire-F4	Double Pulse Strobe	5	21	37
				Rotary Beacon	6	22	38
				Gyra Light	7	23	39
				Rule 17 (dimmable light)	8	24	40
				Momentary Pulse	9	25	41
				Ditch Light (Left or Right)	10	26	42
				Ditch Light (Other side)	11	27	43
				Constant Dim light (50%)	12	28	44
				*Auto-Mars	13	29	45

Place the value attained from the table by the function wire that will control it.

* Auto-Mars: Automatically turns Mars light on when decelerating below 36% speed. This setting also turns the Mars light on steady above 36% speed.

Ditch Light Control

14	CV 63	64		Ditch Light Blink Holdover Time (12 = 1 second, 60 = 5 seconds)
	CV 117	5		Ditch Light Blink Rate (1 = slow, 12 = fast)

Analog (DC) Power Control Turn off Black or Red wire powered functions.

17			Green = 1	Purple = 2
	CV 13	255	Activate power to light functions on DC	
			Brake on DC	
Activate by subtracting 4 from CV 29 in table 1.				

Consist Lighting Control Activate so the direction of travel lights are lit.

18			Green Wire = 1	Purple Wire = 2
	CV 21	0	Other Light Functions	
	CV 22	0	Headlight Functions	White Wire = 1 Yellow Wire = 2

Factory Reset

Sets all CVs with a shaded value back to that value.

20	CV 30	0		As soon as you enter a 2 in either CV 8 or CV 30, The reset is complete.
	CV 8	153		