



Unique features, real performance and exceptional installability

***This manual applies to DCCconcepts ZEN, ZEN BLUE+ and ZEN BLACK Series decoders.
(Some features are however only available in decoders from ZEN software version 12)***

We have often been asked for a more detailed decoder manual, so here it is!

Please note:

The exciting features available from Zen Blue+ and Zen Black decoders were the main motivation for the creation of this very detailed manual, but if you have our original DCCconcepts ZEN decoders, this manual is for you too! That is because as while there are definitely added things that only Zen Blue+ or Zen Black can do, many of the features, functions and CV settings you see here are also applicable to the original Zen decoder range.

An introduction plus several highly detailed manuals:

- Page 1~4: Introduction, specification, Zen decoder wiring and connections.
- Page 1~49: DCCconcepts ZEN BLUE+ and BLACK decoders - The FULL comprehensive manual.
- Page 1~ 15: Part 1: DCCconcepts ZEN BLUE+ and BLACK decoders - Motor control, Adjustment, Stay-Alive connections.
- Page 16~27: Part 2: DCCconcepts ZEN BLUE+ and BLACK decoders - Detailed lighting examples and Active Function setup.
- Page 28~48: Part 3: DCCconcepts BLACK decoders - DCCconcepts advanced ZEN ABC Braking, DCCconcepts advanced ZEN Stopping, ZEN's unique "Automatic Shuttle" control ability and ZEN simplified "Brake on DC".
- AND... Page 49: Addendum and NEW notes on decoder features, instalaltion, use and set-up.

All manuals are available online at www.dccconcepts.com

A few words from us... and our manual's "creator":

- *Most things in here quite simple to do - and we have done our best to describe it all as simply as possible.*
- *CVs are covered in order AND also as part of each specialised area too, so you will always find what you need.*
- *Where setup is complex, we have included examples with every step covered so you can just copy them.*
- *Things like our unique approach to ABC automation are actually quite simple but there ARE some quite complex applications and diagrams in that area too . Blame me for that - sorry! It is NOT because you have to do it that way - it is just because we are excited at just how much our advanced ABC approach can achieve... and I really, really wanted to show you what it could do for you with very little extra effort!*
- *I also want to encourage you to "Have a go" at some of the things we have discussed here, because there is so much more than most modellers ever see, hidden inside every Zen decoder that we create.*
- *From all of us: We hope you enjoy it - thank you for sharing your hobby time with us.*



**Zen Decoders are imagined, designed and manufactured by DCCconcepts Ltd
Our showroom and offices are located in Settle, North Yorkshire BD24 9RP, England
Phone: +44 (0) 1729 821 080 * sales@dccconcepts.com * www.dccconcepts.com**



thinking outside the square



Unique features, real performance and exceptional installability

Introduction to ZEN and a little more about the things covered in this comprehensive manual:

Zen decoder software has always been smooth, clever and easy to use but our new BLUE+ and BLACK decoder ranges take this to a new level, with extended and improved automatic braking abilities and simple-to-use ONE step locomotive set-up.

Our Decoder design ideas do not just accept loco-space problems or installation difficulty... so they are designed to fit where others very probably will not. After all - great features and the best performance are of no value to you unless you can fit a decoder in a loco!

Zen decoders are assembled in an automated facility. Electronic parts have a "best before" date as critical things such as solderable surfaces need to be new for high reliability, so all parts deliveries are always "just in time".

The PCBs that we use are created within hours of assembly so that board surface preparation is still fresh and all surfaces are 100% free of defects and contamination at the time of assembly.

Actual assembly is then carried out by fully automated machinery with superb accuracy.

Critical things such as machine-applied fluxes and solder baths are replaced well before recommended dates so that dry joints cannot happen and defect-free assembly and subsequent reliability can therefore be guaranteed.

Finally, once assembled, all of our decoders are tested at least 3 times before we package them for sale, so we know that they all work perfectly when we sell them and you can be quite confident that reliability is assured.

Stay-Alive: **Zen** BLUE+ and BLACK decoders :

Zen Blue+ and Black decoders have improved "Brown out" protection, so we no longer provide Stay-Alives in each pack. We have also made other changes to Zen stay alive support. You will find full details of this on page 15.

- Zen decoders now have a plug-and-play 3-wire connector for the attachment of Stay-Alives.
- Rather than make Zen stay alives bulky and hard to install, they are now in two parts. A small plug-and-play control board and a selection of varying plug-and-play capacitor banks that you can select to fill your specific need for each locomotive.

Warranty Information:

Zen decoders are made with great care, so we are able to have a simple & easy-to-live-with approach to Zen warranty.

- If any Zen decoder with no visible external damage fails to perform as it should, please return it. If we cannot revive it with a simple factory reset, then we will replace it for you free of charge.
- If a Zen decoder has heat damage, a burn mark on the heat-shrink or any other form of accidental physical damage, then we will replace it for you at 50% of the new decoders recommended retail price.

Decoder pack inclusions:

Every **Zen** decoder is supplied complete and ready to install.

Zen BLUE+ decoders: Supplied complete with any required harness and a detailed manual.

Zen BLACK decoders: Supplied complete with any required harness and a detailed manual.

(Selected models may also be supplied with one DCD-ABC module for you to experiment with)

Additional ABC parts and Accessories:

We are confident that **Zen** BLACK owners will want to exploit the advantages of our ABC automated stopping system so we have also added some new accessory packs that include these very simple braking control boards.

DCD-ABC.3 - A pack of three ABC Automatic Brake Section control boards.

DCD-ABC.6 - A pack of six ABC Automatic Brake Section control boards.

DCD-BDC.3 - A pack of three BDC Automatic "DCCconcepts Simplified Brake on DC" section control boards.

DCD-BDC.6 - A pack of six BDC Automatic "DCCconcepts Simplified Brake on DC" section control boards.

DCD-HDR.6 - A pack containing 6 spare headers, 3x Red, 3x Blue.

Please look at page 15 and our website for details of Stay-Alive, harnesses and other accessories.



Zen Decoders are imagined, designed and manufactured by DCCconcepts Ltd
Our showroom and offices are located in Settle, North Yorkshire BD24 9RP, England
Phone: +44 (0) 1729 821 080 * sales@dccconcepts.com * www.dccconcepts.com

**Part 1: DCCconcepts ZEN Blue, BLUE+ and BLACK decoders
General Specifications, Motor control, Loco Running and Adjustments.**

Model	Peak	Continuous	Functions	Connector	Size (mm)	Actual decoder size
BLUE+ models have a BLUE background. BLACK models have a BLACK background.						(When page is printed at 100%)
ZN218.6 Black	1.1 A	750mA *See notes	6fn x 100mA	21 and 8-pin	23 x 16.5	 (ABC) 6 Function
ZN218.4.2 Black	1.1 A	750mA *See notes	4 x 100mA fn plus 2 x low power function	21 and 8-pin	23 x 16.5	 (ABC) 4 + 2 Function
ZEN Mini Black	1.1 A	750mA *See notes	4 x 100mA	8-pin wired	19 x 11	 (ABC)
ZEN MIDI Black (New High Power)	2.0 A	1.2A *See notes	6 x 100mA	8-pin wired	22 x 13	 (ABC) 6-function High Power
ZEN N18 Blue+	1.1 A	750mA *See notes	4 x 100mA	Next-18	15 x 10	
ZN8D Blue+	1.1 A	750mA *See notes	4 x 100mA	8-pin direct	16 x 8.5	
ZN8H Black	1.1 A	750mA *See notes	2 x 100mA	8-pin wired	16 x 9	 (ABC) 2-Function
ZN6D Blue+	1.1 A	750mA *See notes	2 x 100mA	6-pin direct	14 x 9	
ZN68 Blue+	1.1 A	750mA *See notes	2 x 100mA	6 and 8 pin	14 x 9	
ZN360.6 Black	1.1 A	750mA *See notes	6 x 100mA (Six full power functions)	8-pin direct	16 x 14	 (ABC) 6-Function
ZBHP Black (Buddha)	5 A	3.5 A (Conservative)	6 x 250mA (Six full power functions)	12 terminals	42 x 27	 (ABC) 5 amp 6-Function

POWER NOTES: We have been very conservative in claimed power specifications. As a result, while we use parts that are identical in real-world power specification to those of our competitors, we claim only 750mA power handling where they may claim 1 amp or more. We do this because in reality, they are forgetting to tell you that while their decoder MAY take an amp, it will do so for only a second or two without potential problems! (In reality load any HO decoder to anywhere near an amp and you CAN expect excessive heating in just a second or so. All decoders are weakened or damaged by high heat levels and will definitely burn out if left with that sort of load.) Our more conservative rating will help you have a long life for each decoder. You need to consider this because the load on a decoder is not just the motor current. Every light/LED or other powered accessory has to share the available power, and when the train is long or under load, the current draw of a fully featured loco will often exceed expectations. Load generates heat, and constant load just stresses everything, so being a little conservative in the way you think about power handling will lead to greater long term reliability.



Unique features, real performance and exceptional installability

Part 3: DCCconcepts BLACK decoders - Advanced SHUTTLE control, braking with ABC and Brake on DC. (Advanced ZEN Shuttle control, ABC braking and Advanced Brake on DC are ONLY available with ZEN BLACK)

Zen BLACK ABC Braking abilities:

Having read many reviews of ABC braking performance in decoders made by several popular brands, it was clear to us that some worked well, but overall, there was little or no consistency in the way that they performed, and that with only ONE way to trim slowing or stopping speeds in each brand, results were often less than ideal.

It was also clear that while basic ABC implementation by the user was easy to do and relatively low cost, a little more thought needed to be put into the triggering and activation of ABC, so that it was not necessary to think about "Left and Right rail", to cut more than one rail at any time OR to re-wire an ABC trigger device if it was inadvertently installed backwards...

Most importantly, ABC seemed to be a limited functionality option - and ANY extended ABC use in other brands always seemed to require an expensive add-on device (This was certainly the case with the three "better brands" that we evaluated).

We just could not see why that should be necessary at all!

Finally, we do not like just following along and so yet again, we wanted to add something new. Our objectives were.

- Very simple set-up of ABC.
- Versatile adjustment of ABC with both slow down and stop, intermediate running speed and acceleration rates/distances.
- Implementation of adjustable slow down and stopping sections for automation of terminal station stopping, automatic storage and fiddle yards or even simple and direct signalling integration via ABC for those who wanted it.
- Low cost ABC board with switchable orientation (via easy to use headers).
- Both on-board or external triggering of the ABC board for "ABC section on or off".
- Fully Automated ABC triggered shuttle abilities, all totally within the Zen Black decoder.
- A choice of simple timer adjustment or external triggering for shuttle-related station stops, within the decoder.
- Addition of "multiple, easily set up station or passing loop stops", all totally within the Zen Black decoder.
- Ability to use ABC boards interactively so that "Automated Shuttle Trains" can also share main line use.

We let our imagination loose on this one so **Zen BLACK** and its ABC possibilities were an enjoyable development.

Our ABC implementation in the decoder now does exactly what we wanted, and for those who want to really fine tune it, it has variety of ways to control ABC slow down, stop, then accelerate back to running speed.

The ABC board switching needed total reliability long term so we used moveable headers for durability & reliability - Our ABC boards can also be controlled manually or with external switching from Cobalt motors or any device with reliable switches.

We are especially proud of our fully internal unique self-contained automated DCC-shuttle ability. You can have a simple end-to-end shuttle with adjustable stopping time, or choose to pre-set the number of station or other stops that your train will make - all with simple CV changes that can even be adjusted while the train is running.

All you will need is a Zen Black decoder and a low cost ABC control board to control each action. There is NO need for any external controller or computer interfacing at all. Of course, it works perfectly with all DCC-compliant / compatible controllers.

We did not forget to look at "Brake on DC" abilities with **Zen BLACK** either...

Our Zen Black software even contains a simplified "Brake on DC ability" that makes this legacy approach to braking much easier to implement. It works with only ONE rail cut, and does not need any complex rectification or secondary switching. Using our new approach and the simple BODC board we have created, locos with a Zen Black decoder set to "Brake on DC" now transit section boundaries smoothly and respond only to a correctly oriented rectification.

This makes Zen "Brake on DC" an excellent choice for single track, bi-directional main lines if you do not want to use ABC.



Zen Decoders are imagined, designed and manufactured by DCCconcepts Ltd
Our showroom and offices are located in Settle, North Yorkshire BD24 9RP, England **28**
Phone: +44 (0) 1729 821 080 * sales@dccconcepts.com * www.dccconcepts.com

Unique features, real performance and exceptional installability

Part 3 of this manual is all about ABC control, ABC shuttle and Brake on DC. Simple settings need only CV detail and more complex things benefit from an example (as we prepared for lighting functions) so we will take the same approach here.

Please note:

- ABC braking and Advanced “Brake on DC” (BODC) are available only in **Zen** BLACK Decoders.
- The classic “Brake on DC” ability is however available in both Zen Blue and Zen Blue+ decoders.

ABC control boards, Brake on DC control boards.

- We will show and explain the use and connection of these later in this document.
- We will also show them in place in several clear examples.

ABC control CVs and their adjustment.

- CV27 is the primary decoder instruction CV for ABC and Advanced Brake on DC activation. Setting just CV27 will activate ABC with the ability to stop and slow down PLUS, our ABC shuttle. Just setting CV27 appropriately plus a simple change in CV29 to disable DC running will fully activate Brake on DC with all standard default settings.
- We have listed all other ABC or BODC related CVs here. We will cover them individually AND as examples with diagrams.

CV27 Primary control CV for ABC and advanced BODC Default =0 (inactive) Variables/options = See Chart

An ABC primer - Some simple real-world test track ideas to show you how ABC will work for you.

- Create an isolated section in your test track. It should be long enough for the loco to slow down and stop plus 1 loco length.
- Install an ABC control module to that section and turn it on (see the simple ABC diagram below)).
- Install your Zen Black decoder. Set CV3 and CV4 to give your loco a nice smooth acceleration and deceleration.
- Now, using either Program on the Main OR on the dedicated program track, set CV 27 to 1, 2 or 3 (page 30 has details).
- Run the loco into the ABC section - the train should either slow down smoothly OR come to a smooth, steady stop.
- Turn the ABC control module off, and the loco will now return to normal running speed.
- Change the two BLUE headers on the ABC board from ABC 1 to ABC 2.
- Run the loco into the ABC section - If it slowed in the first test, it will stop this time. If it stopped last time, this time it will slow.
- And... if you have 2x ABC boards - you can use the end of the test track for #2. Set one ABC board to slow, the other to stop. (p32)

THE ABC “TEST TRACK”

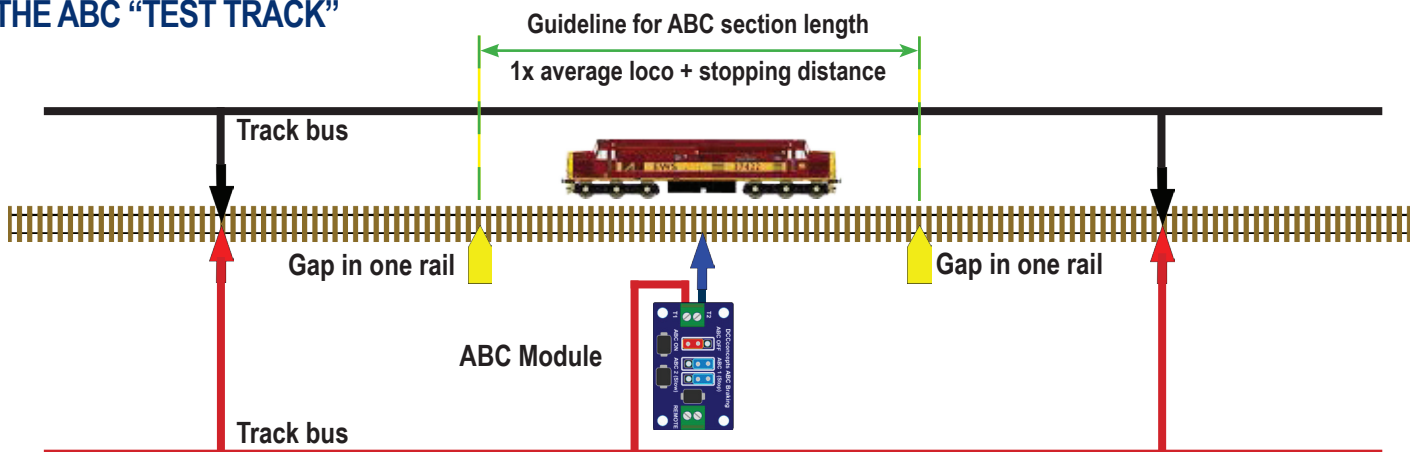

Now you have seen ABC in action, lets look deeper into its abilities - exploring and learning about the CVs that control ABC operations and fine-tune how ABC works... and their many useful options.



Unique features, real performance and exceptional installability

Now we have looked at the basics, lets look at the other CVs that you can use to modify or fine-tune loco stopping distances or initiate other actions. First we will cover ABC braking, then Advanced Brake on DC.

We will follow this with some examples that include everything from creating the gaps to installing and switching the control boards to the track and tuning the way your loco will act when it meets an active section... making you an expert in no time!

CV27=	Expected "ZEN Advanced ABC" action if CV is set to that value	Related CVs
0	ABC control and advanced "Brake on DC" (BODC) will both be inactive / off	Nil
1	<p>ABC is active. A loco running in FORWARD will stop in an activated ABC section that is set to ABC-1 on our ABC module (more++) and will slow down in an active ABC section that is set to ABC-2 on our ABC module (more - -) to the ABC rail.</p> <p>The loco will NOT stop if it is running in the REVERSE direction.</p> <p><i>The loco can still be controlled after stopping. To do this, just change loco direction to REV and use the DCC controller to manually drive it out of the active ABC slow or stop sections. Alternatively, turn the ABC control module off by shorting the Remote terminals.</i></p>	Also see CVs 55, 56, 58.
2	<p>ABC is active. A loco running in REVERSE will stop in an activated ABC section that is set to ABC-1 on our ABC module (more++) and will slow down in an active ABC section that is set to ABC-2 on our ABC module (more - -) to the ABC rail.</p> <p>The loco will NOT stop if it is running in the FORWARD direction.</p> <p><i>The loco can still be controlled after stopping. To do this, just change loco direction to FWD and use the DCC controller to manually drive it out of the active ABC slow or stop sections. Alternatively, turn the ABC control module off by shorting the Remote terminals.</i></p>	Also see CVs 55, 56, 58.
3	<p>ABC is active. The loco will STOP at any active ABC Stopping section that is set to ABC-1 on our ABC module (more++) in BOTH the FORWARD and REVERSE directions.</p> <p>The loco will slow down in any active ABC section that is set to ABC-2 on our ABC module (more - -) to the ABC Rail in BOTH the FORWARD and REVERSE directions.</p> <p>This CV setting is primarily for bi-directional single line working.</p> <p><i>The loco can still be controlled after stopping. To do this, use your DCC controller to change the loco direction. For example, if the loco entered in FWD, change to REV. If it entered the section in REV, change to FWD. You can now back out of the ABC section. Alternatively, just turn the ABC control module off.</i></p>	Also see CVs 55, 56, 57, 58.
4	<p>ZEN Automatic train shuttle with variable timing and unlimited automatic station stops. The ABC board will be more ++ for shuttle ends and more - - for the interim station stops.</p> <p><i>The stop timer CVs are CV59 and CV60. When stopped at any position, the train will wait for the timer settings but can still be manually controlled by either (1) reversing direction and taking over control by using the DCC controller (2) turning the ABC control modules off.</i></p> <p>There are several other options for Shuttle Control. See the Related CVs column at right.</p>	Also see CVs 55, 56, 58, 59, 60
8	ABC activation via a signal control decoder (adjust with CV62 for sensitivity)	
CV27=	Expected ZEN Advanced Brake on DC action if CV is set to that value	Related CVs
16	Advanced Brake on DC. Stop if BODC on, right rail more (+) , left more (-)	DC Running off (CV29)
32	Advanced Brake on DC. Stop if BODC on, right rail more (-) , left more (+)	DC Running off (CV29)
48	Advanced Brake on DC. Stop in either direction if the BODC unit is ON	DC Running off (CV29)

Unique features, real performance and exceptional installability

CV3 CV3 Acceleration is the default reference for ABC / BODC Default = 12 Range = 1~255

CV3 is the default acceleration and is active with ABC, etc. Use CV3 to adjust the way that your locomotive moves off when it leaves an ABC section. Left at its default it will give smooth results, but we do encourage experimentation.

CV4 CV4 Deceleration is the default reference for ABC / BODC Default = 12 Range = 1~255

CV4 is the default / simplest way to adjust ABC related deceleration. Use CV4 to adjust the way that your locomotive slows down or slows and stops when it enters an active ABC section. Left at its default it will give smooth results, but we do like to encourage experimentation. CVs 55, 57 and 58 adjustments are also available (see specific notes relating to their use).

CV55=	Expected "ZEN Advanced ABC" action if CV is set to that value	Related ABC CVs
<i>CV55 settings will apply whether main ABC control CV27 is set to 1, 2 3 or 4</i>		
0	<p>DECELERATE AT SAME CV4 RATE AS NORMAL LOCO DRIVING.</p> <p>If CV55 is left at 0 (Zero) an ABC control module will stop or slow the loco depending on the orientation of the ABC module relative to the ABC rail.</p> <ul style="list-style-type: none"> • Stop effect: ABC will stop the loco at the deceleration rate set into CV4. • Slow effect: ABC will slow the loco to 50% of its entry speed. It will slow down at the deceleration rate set into CV4. <p>Example: If a loco enters an ABC section at Speed Step 60 it will slow down to SS30). Once the loco is released from ABC, acceleration will be as per your CV3 settings.</p>	<p>CV27, CV4 (+CV48 if your locos will move directly from SLOW to STOP sections at any time)</p>
1	<p>A SPECIAL DECELERATION RATE FOR ABC ONLY.</p> <p>If CV55 is set to 1 an ABC control module will stop or slow the loco depending on the orientation of the ABC module relative to the ABC rail.</p> <ul style="list-style-type: none"> • However, the ABC-related deceleration rate will change to act at the rate that you have now pre-set into CV58. This rate will apply ONLY when in an ABC controlled section, so you can have <u>both</u> a normal deceleration rate <u>and</u> an "ABC only" deceleration rate. <p>Note: If you set CV55 to 1, then CV58 also needs to be set to a value above zero).</p>	<p>CV27, CV58 (+CV48 if your locos will move directly from SLOW to STOP sections at any time)</p>
2	<p>SLOW DOWN TO A SPECIFIC SPEED STEP.</p> <p>If CV55 is set to 2, an active ABC module will stop or slow the locomotive depending on its orientation. STOP and SLOW deceleration rates will remain as per your settings in CV4.</p> <ul style="list-style-type: none"> • However - the ABC-Slow action will now slow the loco to a specific speed step. This needs a setting in CV57. The range is 1~128 representing individual speed steps. (Example: if you set CV57 to 15, no matter what speed step the loco is on as it enters the ABC section, it will slow down to SS 15) 	<p>CV27, CV57 (+CV48 if your locos will move directly from SLOW to STOP sections at any time)</p>
3	<p>BOTH SPECIAL DECELERATION RATE AND SPECIFIC SPEED STEP.</p> <ul style="list-style-type: none"> • Setting CV55 to 3 will COMBINE 1 and 2 above, giving you use of BOTH the special deceleration rate set into CV58 <u>and</u> the ability to slow down to a specific speed step. 	<p>CV27, CV57, CV58, 48</p>

CV48 Adjustment if a Loco moves directly from ABC SLOW to ABC STOP Section Default = 15 Range = 1~255

When a locomotive moves directly from an ABC SLOW DOWN section to an ABC STOP section, there will be a short period where the locomotive is in both sections. This may cause the loco to accelerate slightly (It will vary by length of locomotive).

To prevent this, we have added a "Time delay when leaving ABC SLOW option" using CV48. You can adjust it in 255 steps. Each step is equal to 0.1 seconds The default is set at CV48 = 15 or 1.5 seconds. Adjust it individually to suit each of your locomotives.



Unique features, real performance and exceptional installability

CV56=	Additional conditions for ZEN ABC & ABC-SHUTTLE operation	Related CVs
CV56 relates to shuttle stopping time or actions relating to general ABC stopping if CV27 is set to 1, 2, 3 or 4.		
0	<p>CV56 = 0. Timer-controlled intermediate station stops for Zen Shuttle operations.</p> <ul style="list-style-type: none"> If CV27 is set to 4 (For ZEN Shuttle operation) and CV56 is left its default of zero, intermediate station stop timing is controlled by the value that you enter into CV 60. <p>Note - you can also release a loco from an intermediate stop by turning off the ABC module at which the train stopped. (Perhaps by linking to a turnout controlled switch).</p>	CV27, CV4, CV3 CV58
1	<p>CV56 = 1: Interactive control of intermediate station stops for Zen Shuttle operations.</p> <ul style="list-style-type: none"> If CV27 is set to 4 and CV56 is set to 1 the Shuttle end stops will remain timer controlled, but any intermediate station stops will now be controlled <u>ONLY</u> by turning the ABC module ON or OFF. (Stop times that you have set in CV60 will NOT be active) <p>This is a very useful way to arrange semi-automatic ZEN Shuttle operations - using this mode, you can have a shuttle train that also uses the main line, diverting shuttle trains into loops as needed. If the loop turnout is in turn linked to the ABC control module, the loco / shuttle train will be held there until you release it.</p>	CV27, CV4, CV3 CV58
2	<p>CV56 = 2: Terminal or Storage yard mode "Stop and set speed to ZERO".</p> <ul style="list-style-type: none"> If CV27 is set to 1 or 2 and CV56 is set to 2 - When the loco stops at any ABC stop section, the locomotive decoder will automatically set its speed to ZERO. <p>This is an ideal approach for automatically controlled, hidden storage yards and terminal type passenger stations. When the loco gets to an ABC controlled stop section, it will stop and then set its speed to zero. The loco will remain ready for you to either hit reverse and drive it out of the siding, or turn the ABC module off & drive it out if the yard is loop-based.</p>	CV27, CV4, CV3 CV58

CV57 Set this CV to SLOW the locomotive to a SPECIFIC SPEED STEP Default = 12 Range is 1 to 64

CV57 changes the way that the loco will react to a slow down ABC controller

CV57 will NOT be active unless CV55 is also set to 3.

If CV55 is NOT set to 3, the loco will keep slowing down to 50% of the ABC slow-section entry speed step level. However if CV55 is set to 3 AND CV57 is set at any level between 1 and 64 then that is the speed step that the loco will slow down to. CV57 default is set to 12.

- Because the slowing of the loco is so consistent with this approach, it is ideal where an ABC slow section is directly followed by an ABC stop section. This is because having the ability to always approach an ABC stop section at exactly the same speed step will greatly improve the accuracy and consistency of loco stopping distances, making any loco-by-loco fine tuning much easier.
- This highly accurate "Approach slow then stop" ability is of course perfect for passing loop, terminal station and storage or fiddle yard automation - and, of course, it is really effective for restricted speed or signalled areas that need accurate control.

Use this CV sensibly. Always set it to a level that will be below the usual "approach speed" for the ABC controlled slow-down section. If you set it to a speed step that will be above the approach speed, then the loco will speed up!

If the loco will move directly from an ABC SLOW section to an ABC STOP section, then leave CV3 at 12~15 or set CV48 so that it delays any acceleration until after the loco's full wheelbase has passed the "Slow to stop" transition. (See full CV48 detail on page 31)



thinking outside the square



Unique features, real performance and exceptional installability

CV58 Set this CV to have ABC sections with a different deceleration to the rate that you have set into CV4 for normal locomotive driving. **Default = 0** **Active range is 1 to 255**

If left at the default of Zero (0) - the locomotive will continue to use the standard CV4 deceleration rate.

However if CV58 is set at any level between 1 and 255, the loco will use that deceleration rate when in an active ABC section.

- Experiment, but remember that very high values will mean very slow deceleration.
- For the most effective and realistic results, planning for ABC use should consider both the length of the ABC sections and use of the various deceleration rate options before the rails are cut and the ABC modules are installed.

AUTOMATIC SHUTTLE STOP TIMER CVs

CV59 CV 59 sets the wait time AT EACH END of an automated or semi-automatic shuttle train. (CV60 sets the intermediate stop times) **Default = 5** **Active range is 1 to 255**
(1 = 10 seconds) (10 seconds to 42 minutes)

Enabling an automated shuttle train with Zen Black is very simple. Once you have set CV27 to 4 and installed an ABC module at each end of the shuttle route, it is basically ready to go. CV59 lets you adjust the wait time at each end to anything that you want it to be.

CV60 CV 60 sets wait time at any intermediate stop in an automated or semi-automatic shuttle train. (CV59 sets "end station" stop time) **Default = 5** **Active range is 1 to 255**
(1 = 10 seconds) (10 seconds to 42 minutes)

Adding intermediate station stops or even creating a semi-automatic shuttle where the shuttle train can be stopped and held in loops to allow main line trains to pass is simple (with the loops ABC boards controlled via Cobalt point motor switching).

- You can have as many intermediate stops as you want with NO NEED TO CHANGE CVs.
- Just set up the intermediate ABC modules with their direction headers set opposite to those on the Shuttle-end modules.
- In "Shuttle mode", if the intermediate station stop ABC modules are ON - then the loco will stop and wait until the pre-set time expires or earlier if you decide to turn the ABC module off.

ABC module switching can be done with the on-board switch headers, with an external switch, or with switches linked to detectors or any Cobalt point motors that control the ABC activated track the loco is on. Combinations of timing and ABC switching will give many options.

DCCconcepts Advanced Brake on DC activation **Default = off** * Set DC running OFF in CV29
* Set CV27 to 16, 32 or 48

Traditional "Brake on DC" has existed for a long time - However it has rarely been used because it requires an awkward approach to wiring. Both rails needed to be isolated and the section had to be rectified after the entire loco was in the section to prevent problems. That involved either manual control or at least one detector to do the switching at the appropriate time.

We looked at this at the same time as we worked on ABC. We found that a small change made "Brake on DC" much easier.

Our changes have made a significant difference to wiring the layout for Brake on DC.

- DCCconcepts "Advanced Brake on DC" needs only ONE rail to be gapped.
- The Brake on DC section can be left on while the loco enters the section, unlike normal Brake on DC control.
- The rectification needed is simple with very simple connections. (Our low cost DCD-BDC Brake on DC control board is also switchable to let you reverse it or turn it on and off, directly from the headers OR via any form of external switch)

Activation and set-up remains very simple, with only TWO CVs to change.

- Change CV29 to turn off DC running (Reduce CV29 setting by 4.... e.g. If CV29 = 6, make it 2, if its 36, make it 32).
- Change CV27 to engage the Brake on DC action you need (Set CV27 to 16, 32 or 48).

NOTE: ABC Braking & Brake on DC cannot be activated at the same time. Only DCCconcepts ZEN has Advanced Brake on DC.

SEE the BRAKE on DC CONNECTION DIAGRAM ON PAGE 48



Zen Decoders are imagined, designed and manufactured by DCCconcepts Ltd

Our showroom and offices are located in Settle, North Yorkshire BD24 9RP, England **33**

Phone: +44 (0) 1729 821 080 * sales@dccconcepts.com * www.dccconcepts.com

Unique features, real performance and exceptional installability

ABC and Brake on DC examples: The symbols we have used in our drawings

Now we have given you an overview of **Zen** BLACK and its ABC control CVs, we will take a look at some real-world examples, covering wiring, connecting and using DCCconcepts ABC control boards and, of course, the CV settings needed.

Please note: We have shown only the rail breaks and wire connections that relate solely to ABC. Of course, there will be other rail breaks for turnout frogs and other track feeds needed for train power.

A break in ONE rail is yellow looks like this:



A break in BOTH rails looks like this:

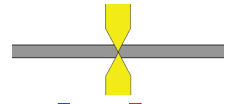

Track connections look like this:

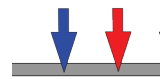

Blue is for ABC, Red is rail 1 and Black is rail 2:

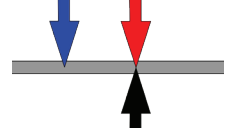

And... an ABC braking module looks like this:

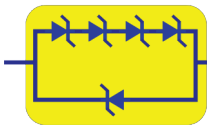

Look for the ABC module orientation in each example.

DCCconcepts advanced ABC and Brake on DC: the DCCconcepts control modules

ABC and Advanced Brake on DC control modules & their connection.

ABC: A basic ABC control circuit is actually relatively simple. 5 x high speed 3 amp diodes modify the DCC signal at track power level, making it asymmetrical.

This is the schematic. If you want to make your own, you can, but use only 3-amp high speed diodes. Create and connect them carefully please. Mistakes will cause train and layout running problems.. Or damage.

BODC: DCCconcepts Advanced brake on DC is simpler than standard brake on DC. However, as it needs to form a more complicated series-parallel arrangement with the section of track that it controls, we do not show it here.

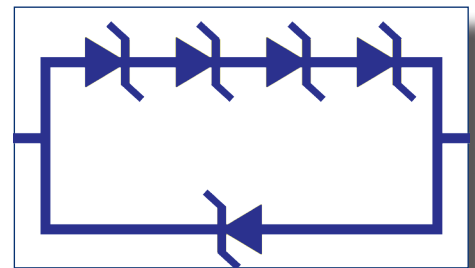

DCCconcepts switchable ABC and Advanced Brake on DC modules.

You may want to turn ABC on and off at times, and the orientation of the modules is very important for correct operation of both ABC and Brake on DC, so a much easier approach to getting up and running is to use our DCCconcepts ready-to-use modules.

These low cost, easy to use modules make it simple for you to use our unique new features. They have screw terminals for connection, so no soldering is needed, and we have built in some useful switching, meaning that you will never have to disconnect anything to turn them on or off... Or to adjust how they work for you.

- Low cost and available in packs of either three or six modules.
- Solder-free SCREW terminals for connection.
- Small size for convenient installation almost anywhere.
- ABC / BODC on-off via on-board or remote control via Cobalt motors, etc.
- Reverse the ABC Module orientation with a simple switch (Via Headers).

DCCconcepts control modules.

For Advanced ABC control

DCD-ABC.3 - Pack of 3 ABC modules

DCD-ABC.6 - Pack of 6 ABC modules

For Advanced BODC control

DCD-BDC.3 - Pack of 3 Brake on DC modules

DCD-BDC.6 - Pack of 6 Brake on DC modules

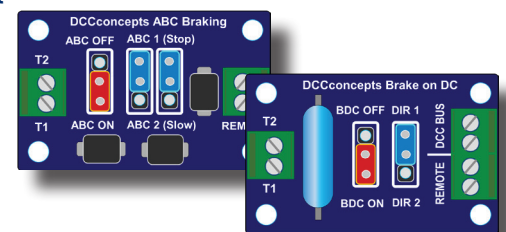

These images are actual size.

USING SLOW AND STOP SECTIONS ADJACENT TO EACH OTHER:

If an ABC SLOW section is directly followed by a STOP section, there will be a loco-length transition as the loco moves from the slow section to the stop section and the locomotive may seem to speed up slightly. To adjust for this, either adjust CV48 to introduce an "Acceleration delay" or just increase the CV3 Acceleration setting to a higher number (default for CV 3 is 12, try 12~16).

Unique features, real performance and exceptional installability

DCCconcepts ABC examples and usage will be covered in pages 34 to 47. An Advanced Brake on DC example is on p 48.

The DCD-ABC control module: Connecting the DCD-ABC control module and using the onboard header switches.

Wiring the DCD-ABC module - Connections.

- Connect terminal T1 to the section of rail that you have isolated to become an ABC control section.
- Connect terminal T2 to the track power bus wiring on the same side as the ABC section rail gap.

Operating the DCD-ABC module - The header switches.

- To turn the ABC section off / turn ABC activity, use the RED header.
- To reverse diode orientation and invert the signal to change the ABC module from STOP loco to SLOW loco, move both the BLUE headers downwards.
- If you want to use an external switch to turn the ABC module on or off, connect it to the two REMOTE terminals (Turn it on to turn ABC off, off for ABC on).
- For automatic control, connect a Cobalt turnout motor switch or similar to the REMOTE terminals. As above, set so that closed contacts will turn ABC off)

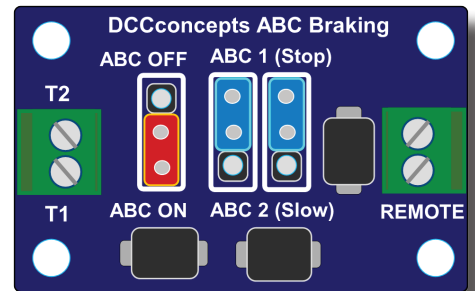

Example #1: Basic ABC use and connection, ABC stopping using one DCD-ABC module.

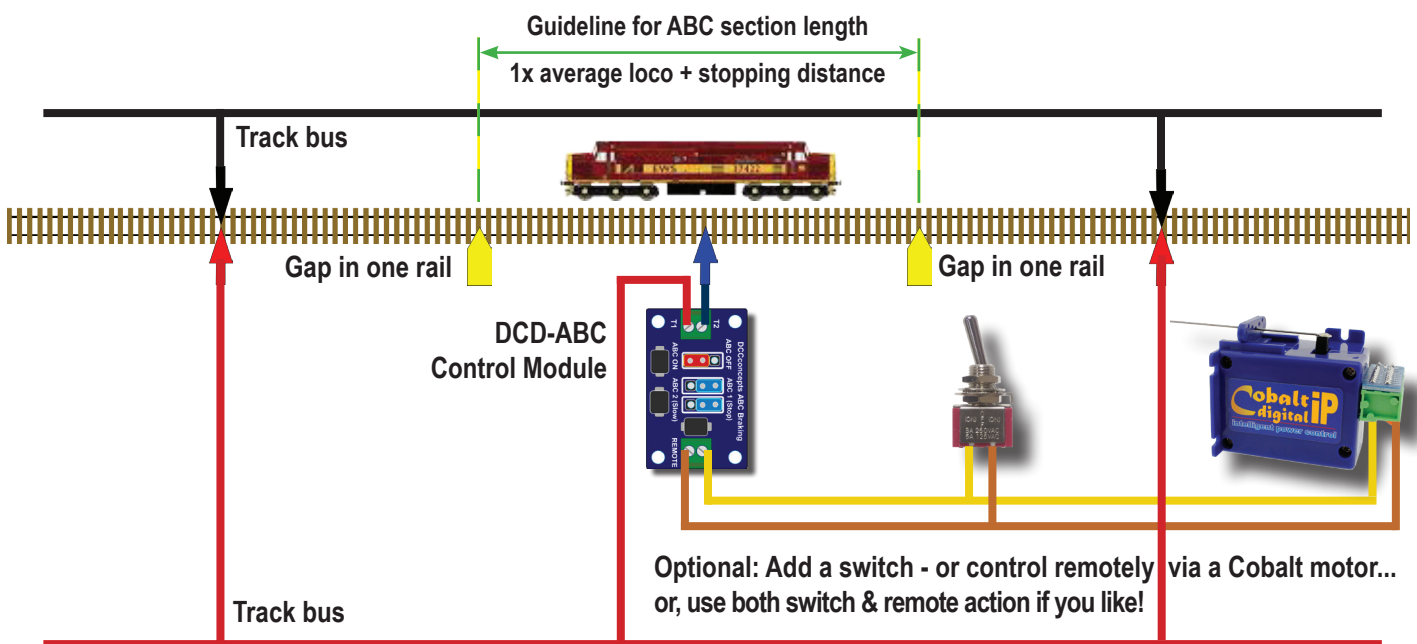

Learning about ABC - SETUP and CV changes to activate Advanced ABC for a single section

- Cut one rail, making the ABC stop section as long as 1 loco plus your preferred / planned braking distance (as above).
- Connect wiring and the DCD-ABC board to the test track as per this diagram.
- Set CV27 to 1 or 2 for now. This allows the loco to react in one direction, but it will ignore the ABC modules in the other (this would be the typical set-up for double track operation).
- Experiment with moving both the BLUE Headers to reverse the asymmetric ABC signal.
- Adjust CV55, 56, 57 or 58 to see what may happen.

and remember....

- If you get lost, confused or stuck, don't worry. Just set CV 8 to 8 to reset the decoder to default settings and start again.

Example #2: Basic ABC use and connection. One ABC slow down section plus one ABC stop section.

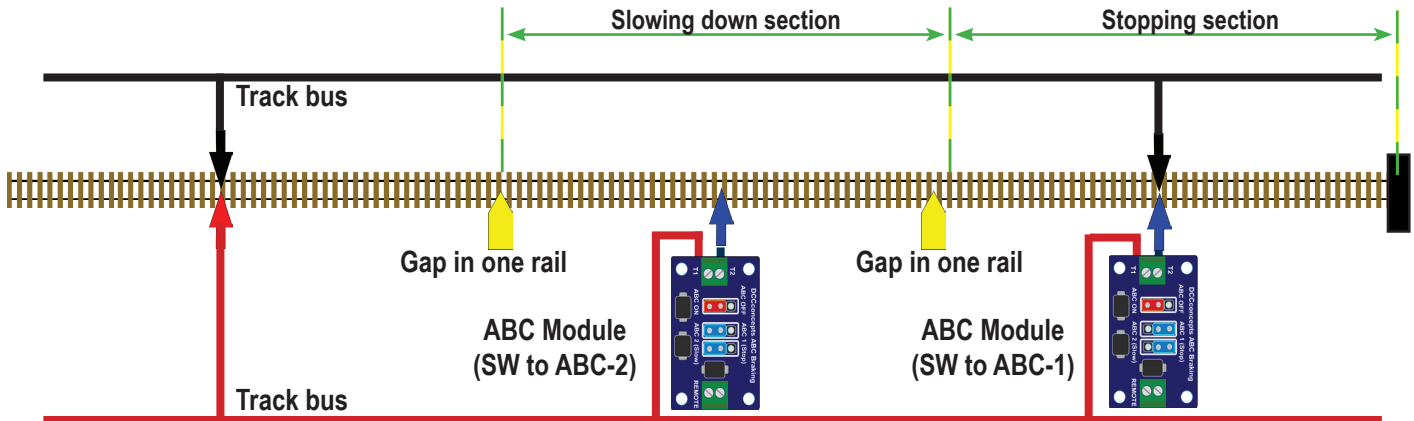

SET-UP and CV changes to activate Advanced ABC for both slowing down and braking.

- Set CV27 to 1 for now. This stops the loco if the headers on the ABC module are set to ABC-1, slows it if they are set to ABC-2.
- Plan for TWO sections, at the end of the test track: each should be at least one loco length + stopping distance.
- Cut the ABC rail, making both the ABC Slow section and the ABC Stop section the planned length (red side in diagram)
- Connect the wiring and the DCD-ABC modules to the test track as per the diagram.
- Set the SLOW section ABC module to ABC-2 and the STOP section ABC module to ABC-1.
- Experiment with changing the headers on each module from ABC-1 to ABC-2 to reverse the asymmetric ABC signal.
- Once the loco stops, you will be able to leave the ABC section by reversing the controller direction and driving out. Because you are now driving the loco against the ABC direction as you reverse out, the SLOW section will be ignored.
- Adjust CV55, 56, 57 or 58 to see what may happen and learn about things like adjusting stopping distance.
- If the loco briefly accelerates between SLOW and STOP, adjust CV48 settings or change CV3 Acceleration to about CV3 = 14

Before we move on to other examples, please remember:

- *If you get lost, confused or stuck, don't worry. Just set CV 8 to 8 to reset the decoder to default settings and start again.*

If you would like some more specific help, or if you have questions, please feel free ask. You can either:

- Telephone us on +44 (0) 1729 821 080
- Email us at salesuk@dccconcepts.com
- Join our modelling & advice forum at www.dccconceptsforum.com. (also available as a direct link from our website).
- Visit us and learn directly from our own staff.

Note:

- We are open 7 days every week and we look forward to seeing or hearing from you 10am to 5pm UK time (summer) and 10am to 4pm (Nov to Feb). Appointments are NOT needed.
- Of course, not everyone works every day, so if you are coming a long way with specific questions to ask, it may be worth checking that our more specialised tech staff are at work that day - just give us a call and we will make sure for you.
- We will always welcome you with a smile and a cup of tea or coffee when you visit.
- We are located directly behind Settle Station... Less than 30 metres from the platforms.
- If you come by car, we have customer parking available right outside the door!

Example #3: DCCconcepts ABC: Train stop - reliable automatic stopping at a terminus, storage or fiddle yard

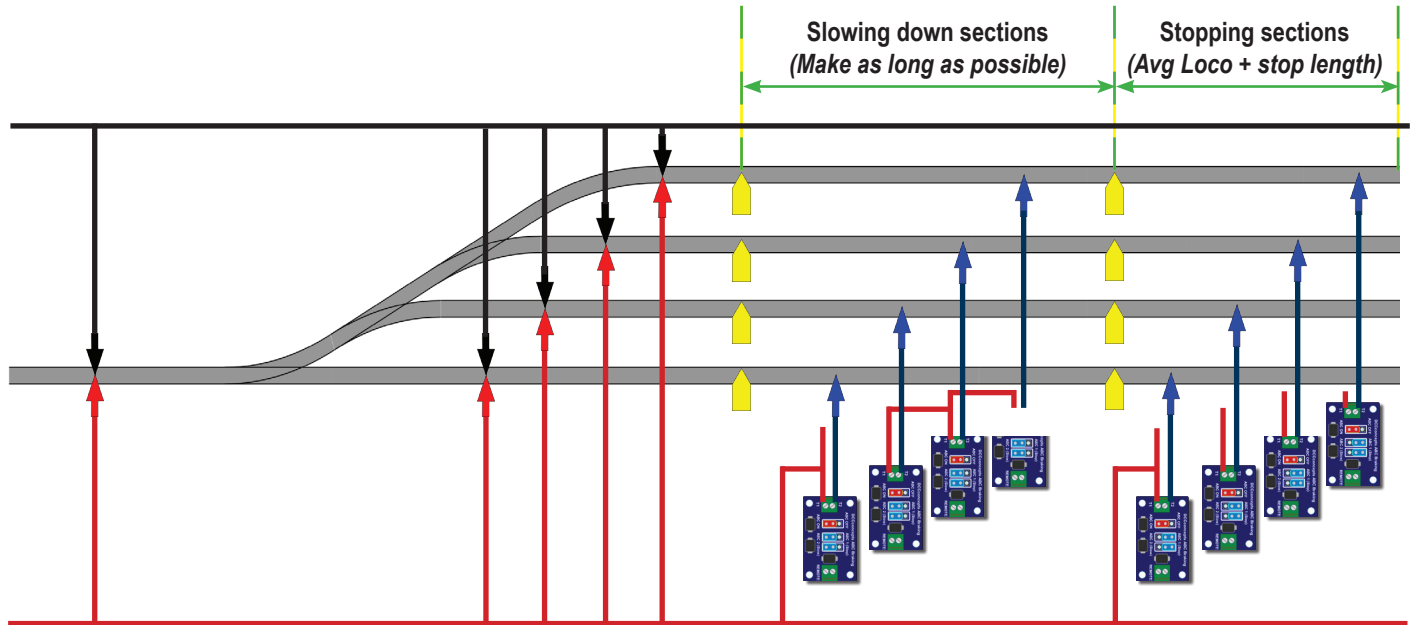

This looks complicated, but it is really the same as our ABC Example 2, but repeated several times.

This is a simple way to set up semi-automatic control of train arrivals at a terminus or storage yard. You will never need to turn the ABC modules off as you can always take control of any loco just by changing direction once it has stopped. You can then just back it out of the ABC sections under full manual control.

- Change CV27 to 1, 2 or 3 depending on your general ABC use (they will all work in this situation).
- Tune deceleration and stop distances. Refer to CV4, CV55, CV57, CV58.
- In this sort of arrangement, we suggest that you utilise CV55 = 2 or 3 and then set CV57 to specify the speed step so that your locos always slow to the same speed step before they meet the ABC stop section. A consistent arrival speed will make it much easier to tune each locomotive's deceleration & stop position.
- Once set up, just drive a loco or train into the sidings and it will slow down as it approaches, automatically stopping at the end.
- If you are careful with the set up of each loco, you will get remarkably consistent stopping distances as each loco will always enter the STOP section at exactly the same speed step.
- Once it has stopped, you can take control again by reversing direction. The loco will start to accelerate back to the same speed setting that it entered the STOP section. You can easily control the speed interactively of course.
- If you want the loco to sit and wait for you to start to drive it out after you have swapped its direction, then set CV56 to 2. Once this has been set, the loco will stop and automatically re-set its speed to 0 (Zero).

Things that you might like to experiment with.

- CV27 directional control of ABC operation (CV27=1, 2, 3).
- You may need to adjust CV48 if locos speed up when transiting from ABC slow sections to ABC stop sections
- Changing the switches (headers) on the ABC modules to see what happens (and connecting via a point motor switch).
- Deceleration adjustment options when in an ABC section, using combinations of CV4, CV55, CV57 and CV58.
- Adjusting different locos or trains (big, small, long, short) so they all stop in identical positions.

Unique features, real performance and exceptional installability

Example #4: Bay platform control and automatic stop at a platform. (Also applicable to passing loops)

To help us to keep the diagram clear, we will show both a Slow and Stop module for the stub-end platform siding, but only a stop module for the loop-related stops. This is only one possibility - you could make this formation with both Slow and Stop ABC modules in all areas, or, of course, create it with only Stop sections in all areas if you wish. A third possibility is one Slow down section at each end of the station area, with Stop modules at each platform.

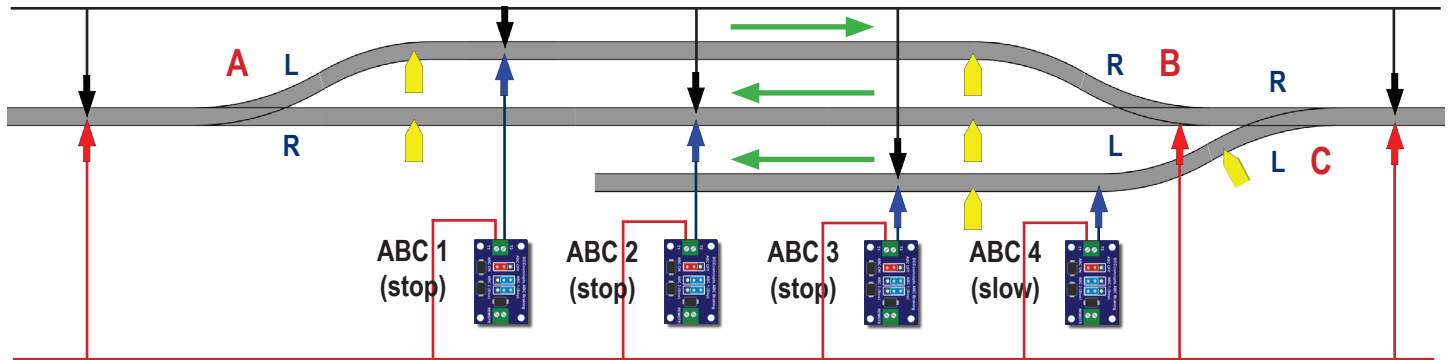

Let's look at this example one area at a time. If we do that, then it will be easier to understand.

Overview:

- General wiring is as per normal DCC practice. Point-work is assumed to be live frog (Electro frog)
- Gaps are created for one module in the loop, one in the main line and TWO modules in the "Bay Siding".
- ABC1 and ABC 2 will need to be set. Connect an SPST on-off switch to the two "REMOTE" terminals. (See image p33)
- CV48 may need adjusting to make sure transition from ABC slow to ABC stop is smooth

Creating semi-automatic interlocking and ABC controlled station stops with DCCconcepts ABC modules.

- To this in an easy to understand way, we will assume constant platform allocation depending on train direction.
- In this case we will set it up for the upper platform to be accessed from right to left, the central platform from left to right and the bay platform siding from right to left (the green arrows in the diagram above).
- Its nice to have both automatic and manual control sometimes, and this is not a problem. The modules can, if needed, be turned off and on manually with an external switch. The switch can just be wired to the "Remote" terminals of the ABC modules in parallel to the turnout motor switching if you choose to add it.

Linking ABC module control to turnout position.

- Now we know how trains will approach each platform, the linking of ABC modules to the turnout position is easier.
- We will link the switches on each motor so that they "interlock" with the ABC control modules automatically.
- We have added connection diagrams covering connection to Cobalt switching on page 39. (If you use other point motor brands, the principals will remain the same but you will need to interpret the wiring accordingly)

Turnout A and B relative to ABC modules 1 and 2.

- We will set up turnout switching the loops and bay siding so that all of the turnouts are independently switched.
- We will connect the "Remote" terminals of ABC 1 and ABC 2 to the SPDT switches on the Cobalt turnout motors that control turnouts A, B and C. (To make it easier, the two modules in the bay platform will not need switching at all).

The logic will now be as follows.

- When turnout A is set for the upper loop, but turnout B and C are not, the ABC automated station stop in the loop is active.
- When turnout B and C are set for the main, but turnout A is not, the ABC automated station stop for the main is active.
- When turnouts A, B and C align for a clear through route, via either the loop or main, the train will not be stopped on that route.

Unique features, real performance and exceptional installability

Example #4 continued: Connection for turnout motor switches and DCD-ABC module via remote terminals

- Turnout motors A and B control the loop, but the line is not actually ever clear unless C has also been set to the main.
- Therefore C acts as an added safety interlock and will not allow the ABC modules to turn on unless it is also properly set.
- To do this, we wire the connections to the ABC board "Remote" terminals via the switches on all three Cobalt motors.

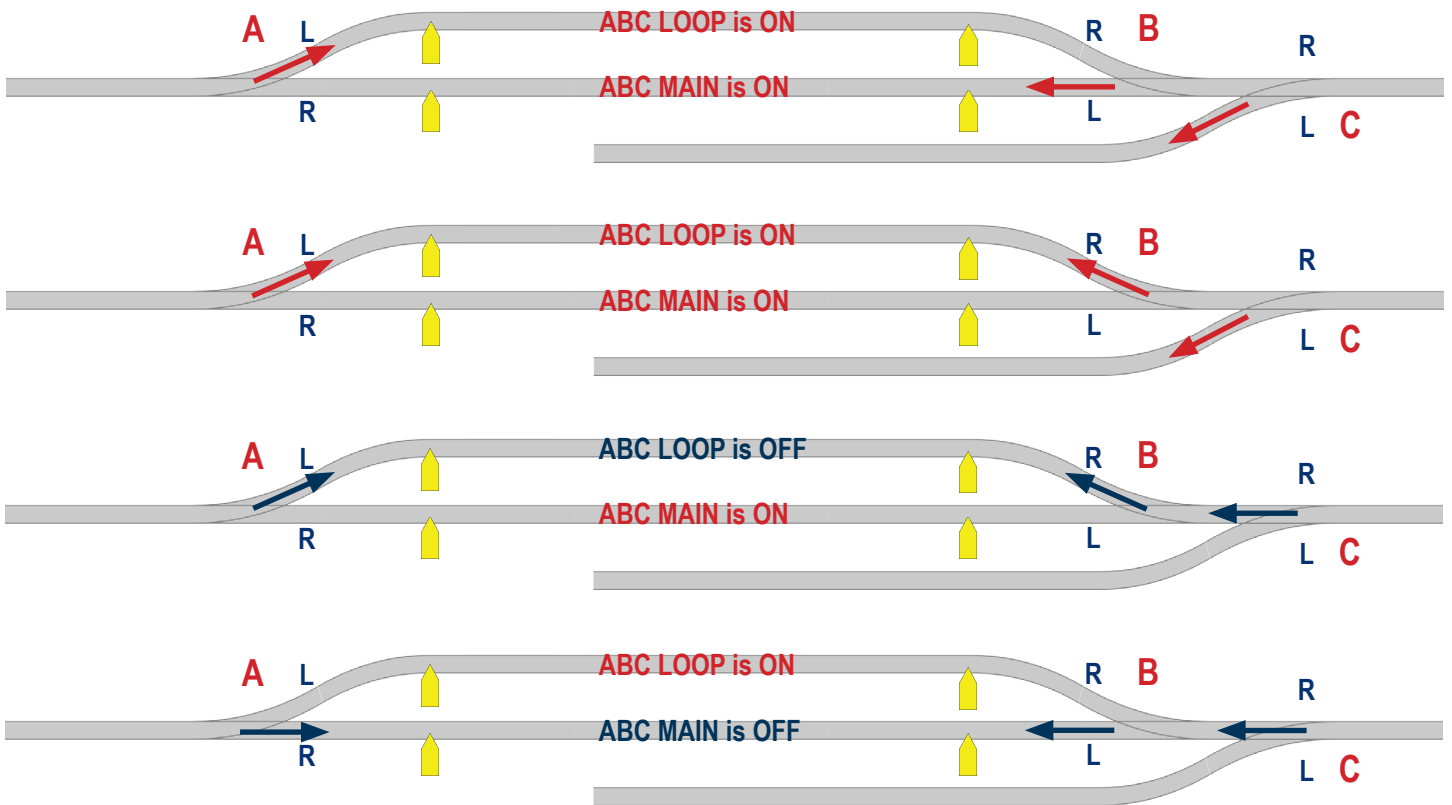

Turning ABC on or off?

If the remote terminals are open, then ABC is on. If shorted, ABC will be off

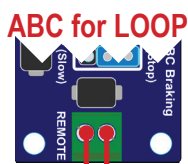

REMOTE TERMINALS
Of course, the ABC on/off jumper must be in the ABC ON position to use them.

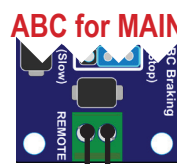

RED wire:
switches the ABC module for LOOP.

BLACK wire:
switches the ABC module for MAIN.

GREEN wire:
Interlocks the ABC modules for the loop and main

BLUE wire:
Interlocks the bay siding turnout (C) with ABC control for the loop and main

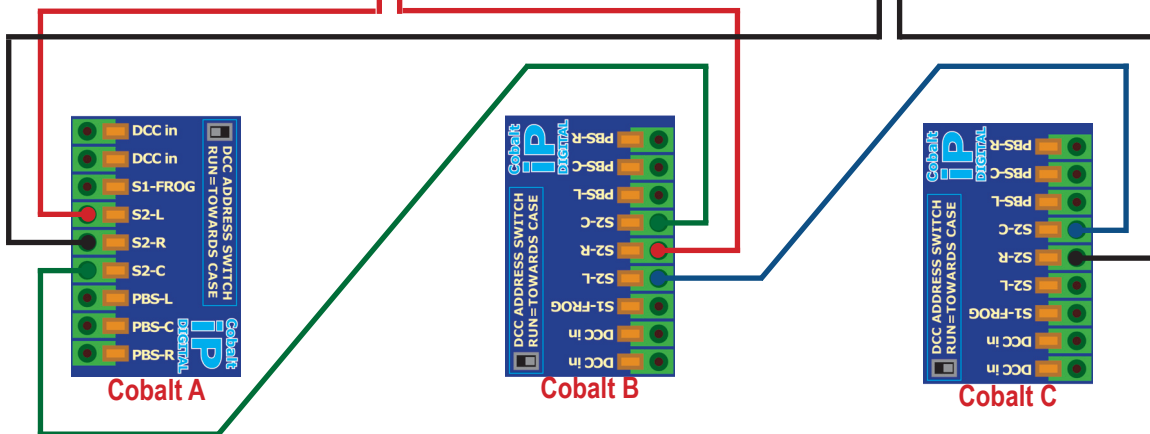

Example #5A: A fully automated hidden LOOP type storage yard with ABC & safety interlocks on entry and exit.

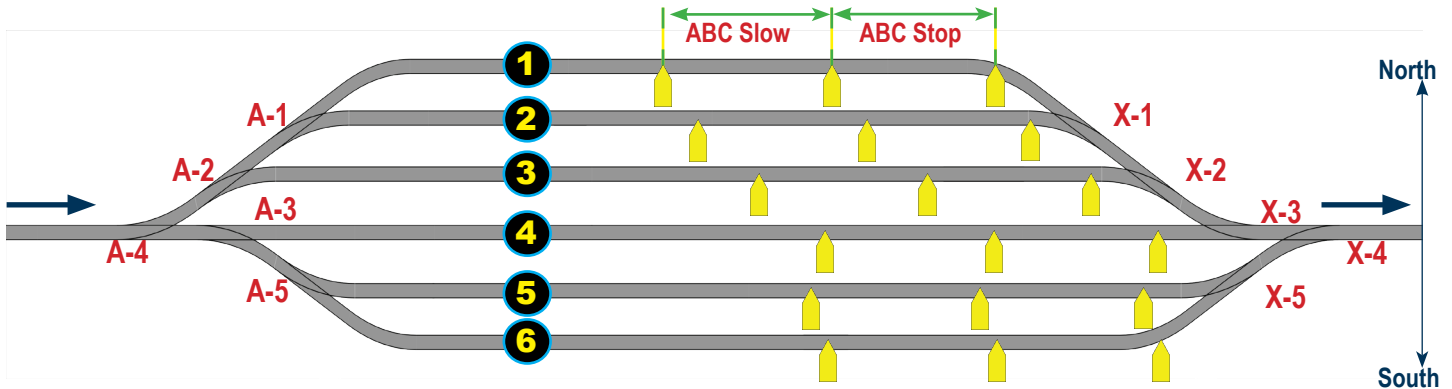

All of the ABC processes are covered in previous examples, so we are only going to describe “how to wire it” here. This will be enough for many - but if you need more, we will follow up with an extended description with more diagrams online. It will be called “ABC controlled storage yard” and you will find it in our manuals/advice section at www.dccconcepts.com.

General assumptions:

- CV48 has been adjusted to add delay / prevent locos speeding up when transiting from ABC slow sections to ABC stop sections.
- General wiring is as per normal DCC practice. As always, do it well and for best results do not compromise!
- Turnout motors are presumed to be from DCCconcepts Cobalt range: either Cobalt-SS, Omega, iP Analog or iP Digital. (This same approach will of course also work with other brands that have reliable SPDT switches for you to use.)
- Tracks are numbered 1 to 6, running from top to bottom.
- Entry & Exit turnouts are independently operated as the switches on the turnout motors will manage the ABC module switching.
- We will assume that yard arrival / entry is from the left, and the yard exit is towards the right.
- Turnouts will be named A-1 to A-5 (Arrival 1 to Arrival 5) and X-1 to X-5 (Exit 1 to Exit 5) in our notes below.
- Turnout position is described as north and south rather than normal or reversed or left and right to keep it understandable for all.

Other guidance:

- Entry & Exit ends of the yard should be independent as switches on the Cobalt motors will manage the ABC module switching.
- Because you can interface turnout motor switches with the external switching of the DCCconcepts ABC modules, interlocking of turnout motors and ABC control is easy - meaning that trains will ALWAYS stop where they should.
- Because the interlocking requires the route to be properly set before a train is released, once this is set up properly, a train cannot be driven out of the yard until the route is properly set, making it impossible for a train to run over a turnout that is set against it.
- When a train is stopped at the end of the storage yard tracks it will, by default, remember its speed settings. Therefore you could run an entire sequence of trains without doing anything other than setting entry and exit routes!
- Simple diode logic will let you select entry and exit routes with a single switch rather than needing individual motor control. Please see the diode matrix chart on page 43.
- The DCCconcepts DCW-DM1 diode matrix kit makes creating routes easy so we have used it here (see pages 42 and 43).
- To interlock ABC modules with the turnout switches, the “Remote” terminals of the ABC modules are linked to the SPDT switches on one or more Cobalt turnout motors. When the switch is OPEN, the ABC module is on, when closed, ABC module is OFF.
- Where a route uses more than one turnout motor, then the Cobalt motor’s on-board switches are wired in series, so that unless all motors are properly aligned, the module will not turn off and allow the train to proceed.
- A simple logic list will make setting this up relatively simple - some examples that may help you think your own designs through:
 - * Access route for track 3 is A-4 North, A-2 South
 - * Access route for track 5 is A-4 South, A-3 South, A-5 North
 - * Exit route for track 1 is X-1 North, X-2 North, X-3 North, X-4 North
 - * Exit route for track 4 is X-3 South, X-4 North

Unique features, real performance and exceptional installability

Example #5B: Wiring the Cobalt motor SPDT switches so that they interlock ABC. This ensures that **ONLY** the ABC board relevant to the route out of the yard that is properly set up is turned off - allowing **ONLY** that loco to move.

- We really only need to control the ABC Stop boards to stop and release a loco
- But - if you **DO** want to turn both off, wire the remote terminals of the ABC Slow & ABC Stop boards together in parallel.

Operations:

- If **ENTRY** and **EXIT** ends are set the same, then the train will continue.
- If **EXIT** is not the same as **ENTRY**, the train will slow down and stop.

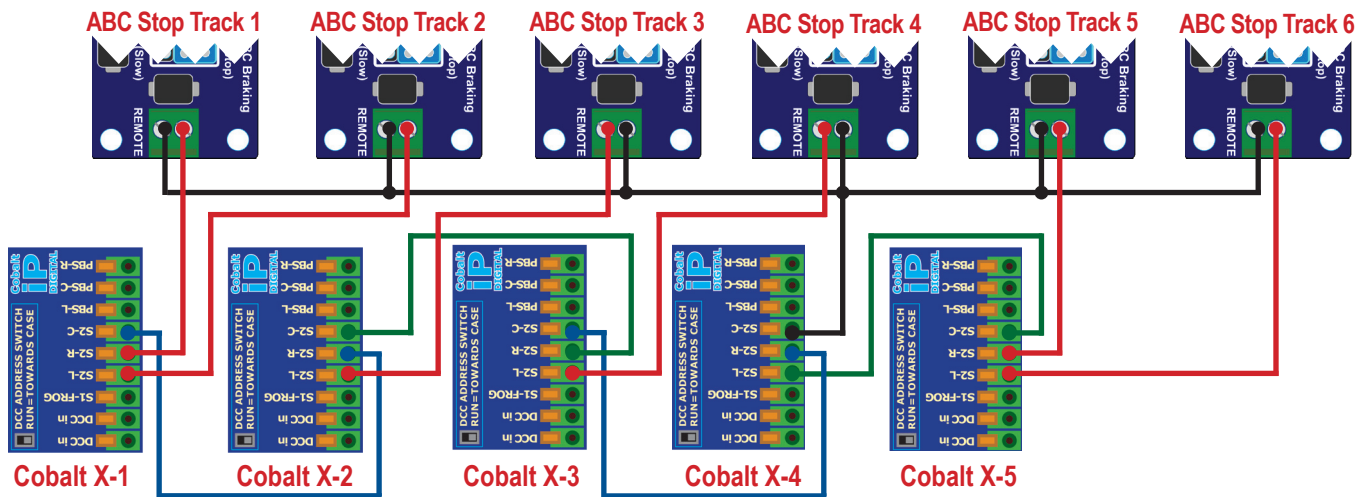
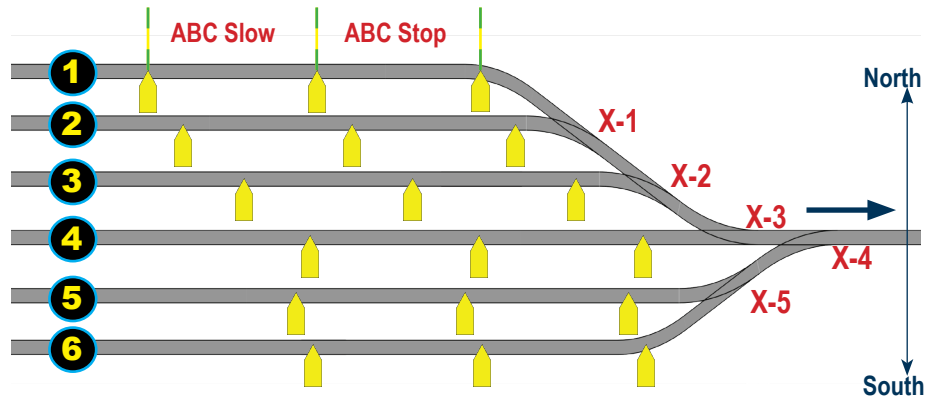

RED wire: Shows which wires control each ABC Stop module. Cobalt X-1 and X-5 each control two, the others just one.

BLACK wires: These are a common wire for all the ABC modules. Link it to Cobalt X-4 - it is then inter-linked to all other motors.

GREEN & BLUE wires: We alternated colour to make the wiring clearer. These wires complete the interlocking of the motors.

Note on wiring the Cobalt SPDT switches:

- Approach this one step at a time and it is quite easy to do.
- First wire the common and link it to X-4's COMMON switch terminal.
- Follow this by wiring the red switch wires, then add the green/blue. (No need for two colours of course)
- If you want **MORE** or **LESS** tracks, use this diagram and add or delete mid-positioned motors accordingly.
- If you need help with the wiring of a different yard design, then please contact us and we will do our best to assist you.

A note about operating this yard:

- You will need to adjust CV48 if your locos speed up when transiting from ABC slow sections to ABC stop sections (Page 31)
- Once the ABC boards are connected and the motors are wired for operation / interlocked as above, it is in fact ready to go if you wish to work manually changing one motor at a time
- If your DCC system allows it, you could easily create macros or "routes" for each entry and exit route.
- Alternately, diagrams C and D in this section show you how to set up simple "One button per route" diode matrix control.

Unique features, real performance and exceptional installability

Example #5C: Wiring the Cobalt motor Manual control switches so that one button can set each ENTRY route.

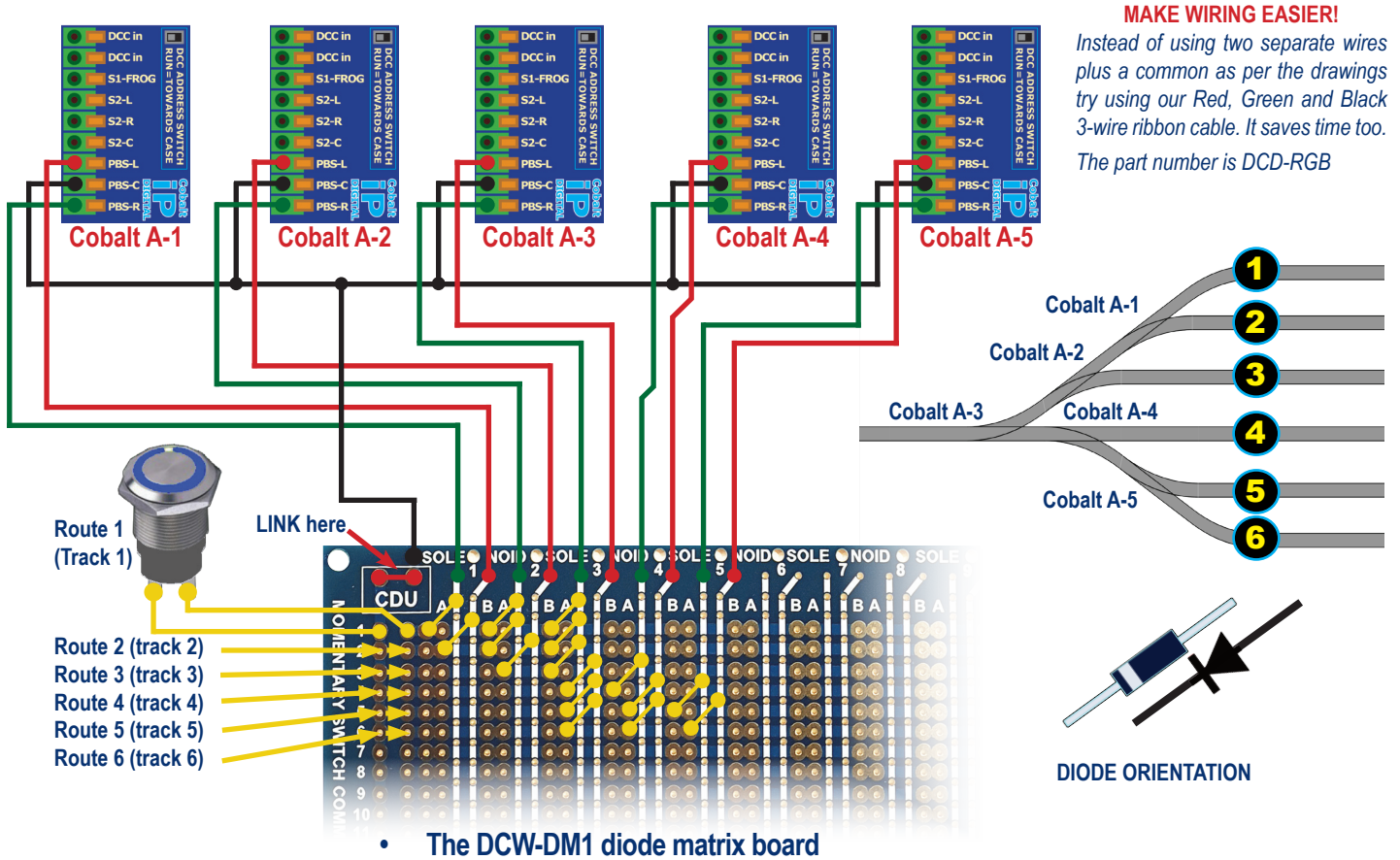

Both the entry and exit route-control diagrams will work equally well with Cobalt iP Digital or Cobalt-SS.

Of course they will also work well with our Cobalt iP Analog/Omega turnout motors in combination with our AD2, AD4, AD6 or AD8 FX series accessory decoders. You could also just create a "Route" or macro in your DCC system!

Don't be intimidated by the appearance of lots of wires. It is after all only the same set of connection 5 times!

- You can use simple push-button momentary switches for route control if you wish.
- Choose ANY normally off push button. (We do recommend that you buy good quality switches though - low cost switches are subject to failure and contact "Bounce".) Whatever you choose, the switches will NOT be subjected to high power.
- If you are using DCCconcepts Cobalt motors, you should NOT add power to the diode matrix at all as it will damage the motors. You should orient the diodes as per the inset image in each diagram.

Using solenoids instead of Cobalt:

- If you are using solenoids, you will need a power supply and a CDU. The DCCconcepts CDU-2 is by far the best approach as it has huge power ability and is one "plug in box" that does the lot with no wiring other than the output connections.
- For solenoid use, please swap all the diodes end-for-end but use the same layout (also replace the LINK with a CDU)
- Solenoids will use the left/right/common connections as per the Diode matrix board instructions. The switch connections would exactly be the same. The Diode matrix instructions in the DCW-DM1 pack cover all solenoid wiring.

Unique features, real performance and exceptional installability

Example #5D: Wiring the Cobalt motor Manual control switches so that one button can set each EXIT route.

MAKE WIRING EASIER!

Instead of using two separate wires plus a common as per the drawings try using our Red, Green and Black 3-wire ribbon cable. It saves time too.

The part number is DCD-RGB

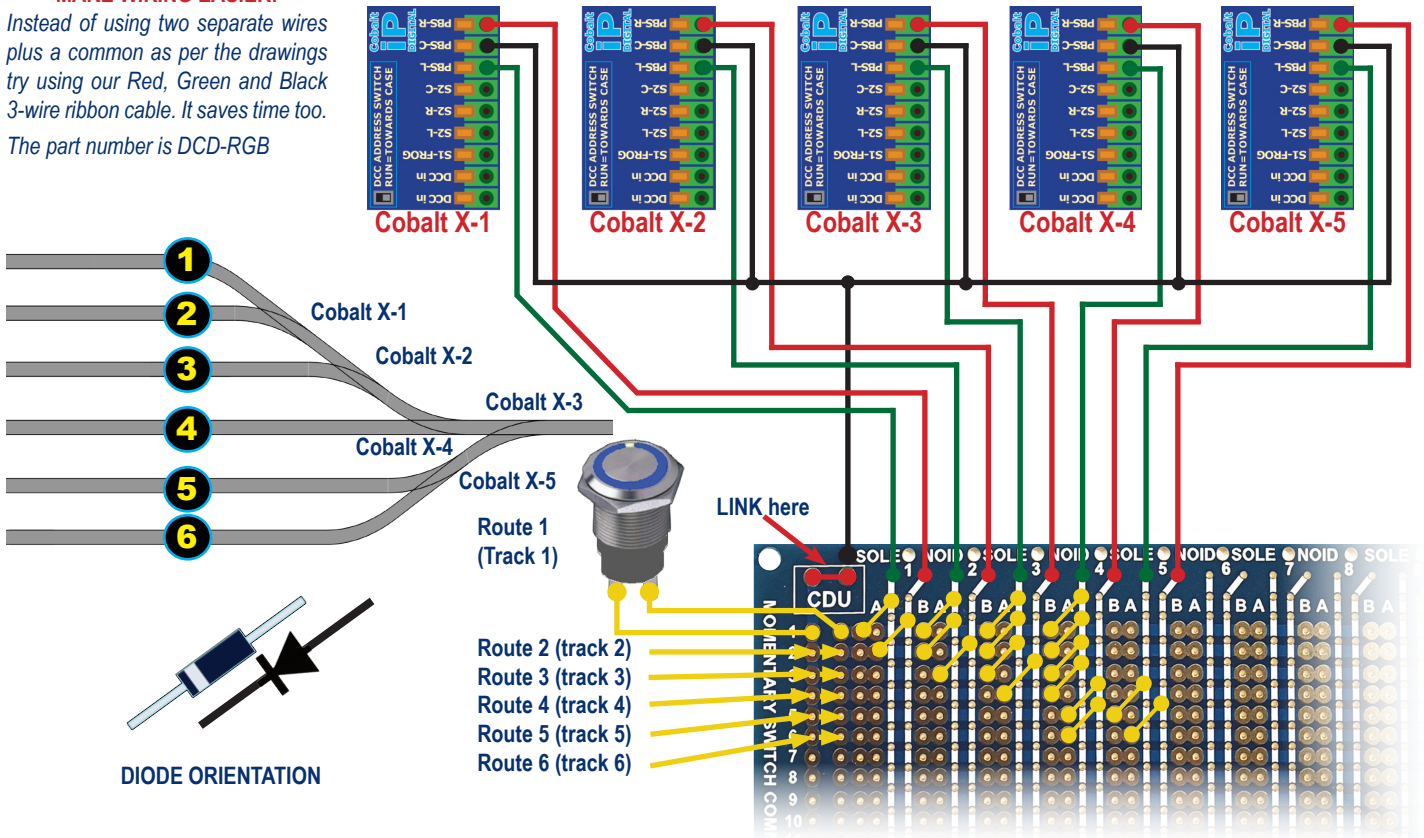

• The DCW-DM1 diode matrix board

Both the entry and exit route-control diagrams will work equally well with Cobalt iP Digital or Cobalt-SS.

Of course they will also work well with our Cobalt iP Analog/Omega turnout motors in combination with our AD1-HP, AD2, AD4, AD6 or AD8 Accessory decoders. You could also just create a "Route" or macro in your DCC system!

Don't be intimidated by the appearance of lots of wires. It is after all only the same set of connection several times!

- You can use simple push-button momentary switches for route control if you wish.
- Choose ANY normally off push button. (We do recommend that you buy good quality switches though - low cost switches are subject to failure and contact "Bounce".) Whatever you choose, the switches will NOT be subjected to high power.
- If you are using DCCconcepts Cobalt motors, you should NOT add power to the diode matrix at all as it will damage the motors. and you should orient the diodes at per the inset image in each diagram.

Using solenoids instead of Cobalt:

- If you are using solenoids, you will need a power supply and a CDU. The DCCconcepts CDU-2 is by far the best approach as it has huge power ability and is one "plug in box" that does the lot with no wiring other than the output connections.
- For solenoid use, please swap all the diodes end-for-end but use the same matrix layout as per page 42.
- Solenoids will use the left/right/common connections as per the Diode matrix board instructions. The switch connections would exactly be the same. The Diode matrix instructions in the DCW-DM1 pack cover all solenoid wiring.

DCCconcepts **Zen** BLACK ABC Shuttle.

Automatic Shuttle operation with intermediate station stops, all managed by your **Zen** BLACK decoder. The basic DCCconcepts Zen ABC shuttle is simplicity itself.

Once you have installed DCCconcepts ABC-capable Zen Black decoder, you will need only two DCD-ABC modules to act as stopping triggers for the shuttle train. If you would like to have one or more intermediate stops, just add more ABC modules.

- Orient the modules one way for “Stop & reverse”, the other for “Stop & continue”.
- Set CV27 to 4 to activate the shuttle ability.
- Set the timer CVs for end of shuttle stop and reverse (CV59). If needed, also set the Stop and Continue timer (CV60)
- You are now able to run a shuttle. Changing other CVs will let you adjust slowdown or other things if you wish.

SHUTTLE example #1: DCCconcepts ABC Shuttle - The basic end-to-end shuttle with no intermediate stops

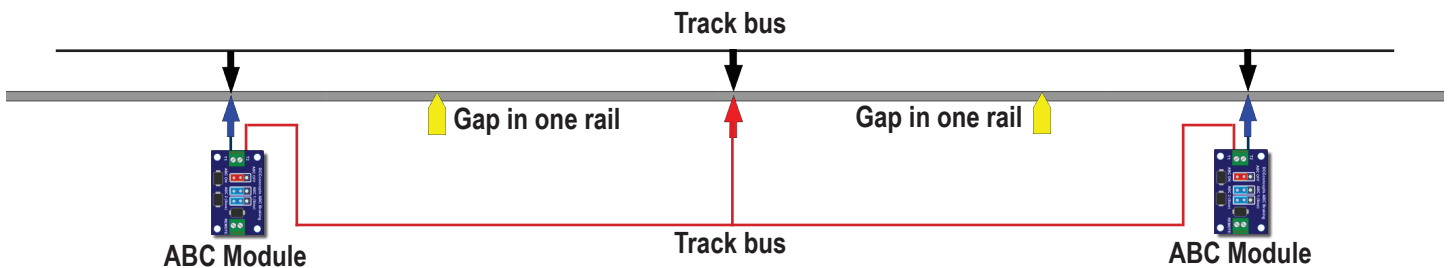

The basic DCCconcepts ABC shuttle is a simple thing to set up.

You will need only two DCD-ABC modules to act as the stopping triggers for the shuttle train.

- Gap the rails to create the end-stop sections. (As for other stop areas, one loco length plus stopping distance).
- Install the two ABC modules. Set the ABC module header switches to the ABC-2 position.

Decoder Set-up:

- Set the decoder - DCCconcepts ABC Shuttle activity is initiated by setting CV27 to 4.
- Set the stop timer CV59. The delay is 10 seconds for each step (experiment low, set final time later).
- Start the loco running with your DCC system, then leave the shuttle operation to your Zen decoder. (If it does not stop initially, then change ABC 1 to ABC 2 or vice versa by moving the Blue headers)
- If you want to adjust the rate at which the train stops, Adjust CV4. Alternately, adjust CV55/56/57/58.

Note please:

- Shuttle mode does not prevent normal operation. (providing ABC modules are off OR loco is in a non-shuttle area)
- A loco set to respond to shuttle mode can also be driven normally.
- You can take over driving simply by using the throttle control of your DCC system at any time. If the train is currently stopped at an end or intermediate stop, you can take over by pressing the direction button OR turning ABC modules off.

Enjoy playing with your shuttle train - it is a great way to get used to ABC braking and how it works and remember, if you get stuck, lost or confused, just set CV 8 to 8 to re-set the decoder to default settings & start again.

DCCconcepts Zen BLACK ABC Shuttle.

Automatic Shuttle operation with intermediate station stops, all managed by your **Zen** BLACK decoder.

SHUTTLE example #2: DCCconcepts ABC Shuttle - An end-to-end shuttle with an added station stop.

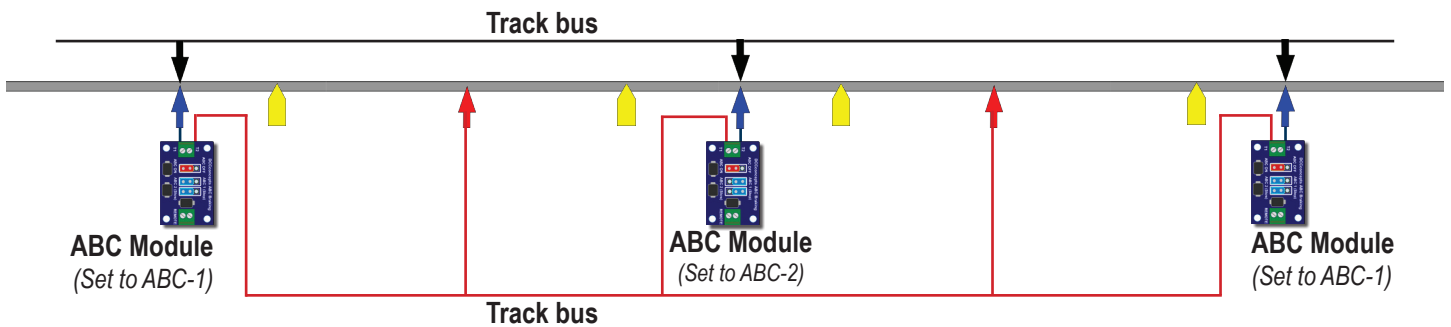

Adding one or more intermediate station stops to DCCconcepts ABC shuttle is almost no effort at all!

You can add one, two or a dozen or more station stops - and apart from setting the "stop time" in the decoder, there are no other adjustments needed if the line is a dedicated shuttle track.

It is very simple and low cost to add them as all you will need is one additional DCD-ABC module per station stop... Installation is also easy - just a couple of rail cuts to make and a few minutes to wire the ABC module (set to ABC2 to the rail).

- Gap the rails to create the intermediate section. (As for other stopping areas, one loco length plus stopping distance).
- Install the ABC module. Set the ABC modules two Blue switch headers to the ABC-1 position.

Decoder Set-up:

- Set the decoder - DCCconcepts ABC Shuttle activity is initiated by setting CV27 to 4.
- Set the INTERMEDIATE stop timer CV60. The delay is 10 seconds or each step (experiment low, set final time later).
- Start the loco running with your DCC system, then leave the shuttle operation to your Zen decoder.
- The loco should now stop and wait a while when it arrives at the intermediate station. (If it stops then reverses instead of proceeding, change the ABC module's Blue switch headers)
- If you want to adjust the rate at which the train stops, adjust CV4. Alternately, adjust CV55/56/57/58.

Note please:

- Shuttle mode does not prevent normal train driving in non-ABC areas of operation.
- A loco set to respond to shuttle mode can also be driven normally.
- You can also take over driving during a station stop by pressing the direction switch on your DCC controller then driving the train out of the section - OR by turning the ABC section off.

Enjoy operating your shuttle train - it is a great way to get used to ABC braking and how it works and remember, if you get stuck, lost or confused, just set CV 8 to 8 to re-set the decoder to default settings & start again.

DCCconcepts Zen BLACK ABC Shuttle.

Automatic Shuttle operation with intermediate station stops, all managed by your **Zen** BLACK decoder.

SHUTTLE example #3: DCCconcepts ABC Shuttle - More than one shuttle train running, with a passing loop in the middle for added interest and flexibility of operation.

Now the first examples have established what things are, we'll just focus on the lines and symbols to keep the drawings clearer!

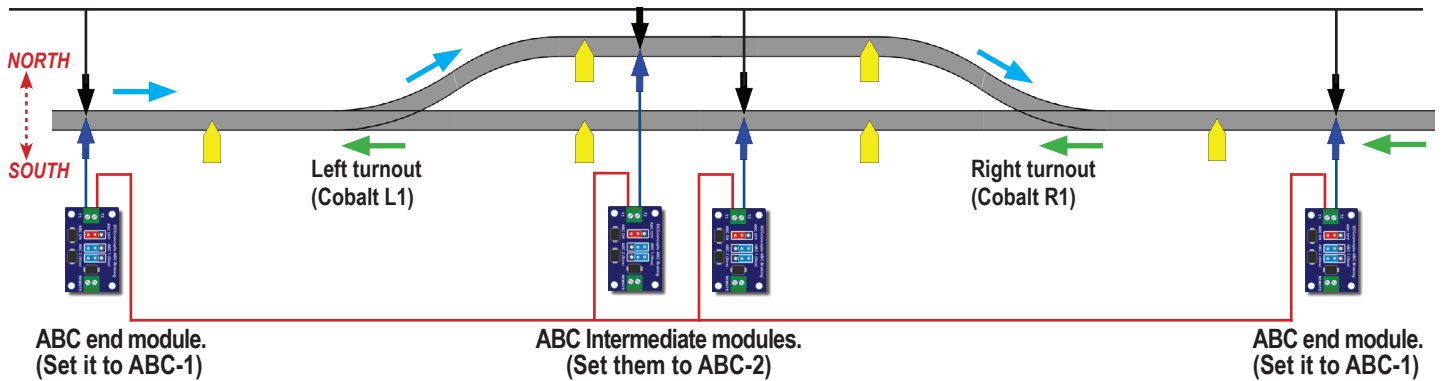

Setup, Settings and the interfacing of ABC modules with turnouts for this dual shuttle configuration.

The ABC modules:

- Wire as per the diagram.
- Set the two ABC modules at each end of the shuttle track to ABC-2
- Set the two ABC modules in the centre of the shuttle track to ABC-1

The Decoder settings:

- Set CV27 to 4 to set the decoder to shuttle mode.
- Set shuttle END-stop wait time with CV55.
- Set shuttle action for intermediate stop sections by setting CV56 to 2. This tells the decoder to stop & stay at an intermediate stop section until the ABC module is turned off. (We will link them to the Cobalt motors driving the turnouts to achieve this).
- Set up the decoder deceleration to your preference. (You can leave at default or use CVs 4, 55, 58 to influence this)

The interlocking of ABC modules and Cobalt motor-driven turnout control to prevent conflict:

Please see the drawing on the next page for how this is done.

- Using standard UK practice, a train heading West > East (pale blue arrows) would take the route through the upper loop and a train heading East < West (pale green arrows) would transit the centre area via the lower loop (main).
- Interface the remote terminals of ABC modules L1 and L2 with the Cobalt turnout motors SPDT switches so that they are either on or off depending on the turnout position.... OR can allow direct transit without stopping.
- Wire the switch terminals of the Cobalt turnout motors so that you have several options, each selected by a single button. (1) straight through via loop (2) straight through via Main (3) Alternate turnout position to stop trains at the station and finally, (4) release trains when stopped at the station via option 3
- The above can be automated with some thought. Perhaps, add detectors or create a route via your DCC system to switch the turnouts digitally. (Possible with either Cobalt iP Digital or iP Analog / Omega via an AD-Series DCC decoder).

Unique features, real performance and exceptional installability

DCCconcepts Zen BLACK ABC Shuttle.

Automatic Shuttle operation with intermediate station stops, all managed by your Zen BLACK decoder.

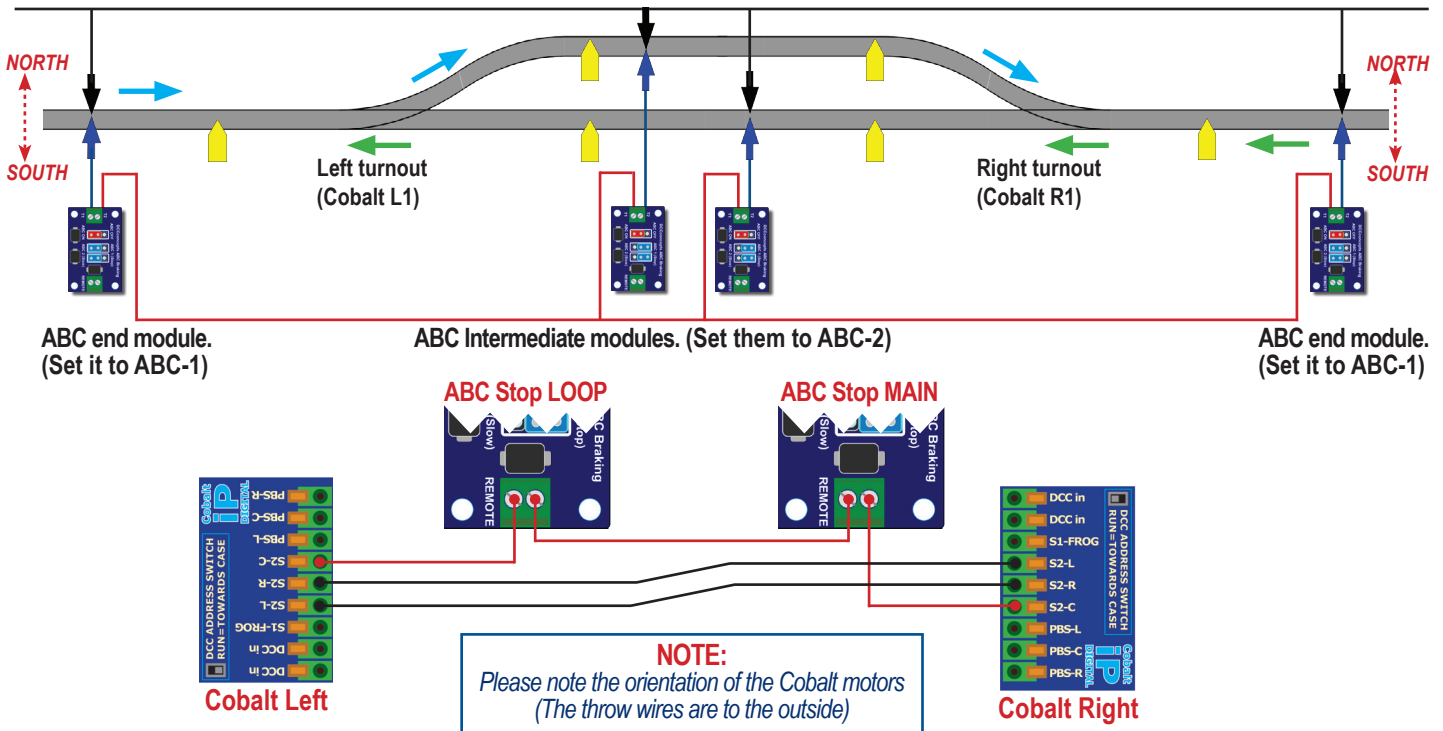

Wiring the ABC modules:

- This diagram shows how to wire the ABC modules, interlocking them to be ON when L1 = North and R1 = South.
- In all other switch positions (L1 = North, R1 = North or L1 = South and R1 = south), ABC modules will be off or inactive.

Controlling the Cobalt motors:

- You could use Cobalt Alpha, your DCC handset or route control (a macro) to change the motors if you wish.
- Basic control: using standard SPDT switches, this is how we do it. Indication is via the switch toggle position as below.

“ABC Shuttle” Station stops OFF (Both L1 and R1 set to loop)

“ABC Shuttle” Station stops active (L1 Set for loop, R1 set for main)

“ABC Shuttle” Station stops OFF (Both L1 & R1 set to main)

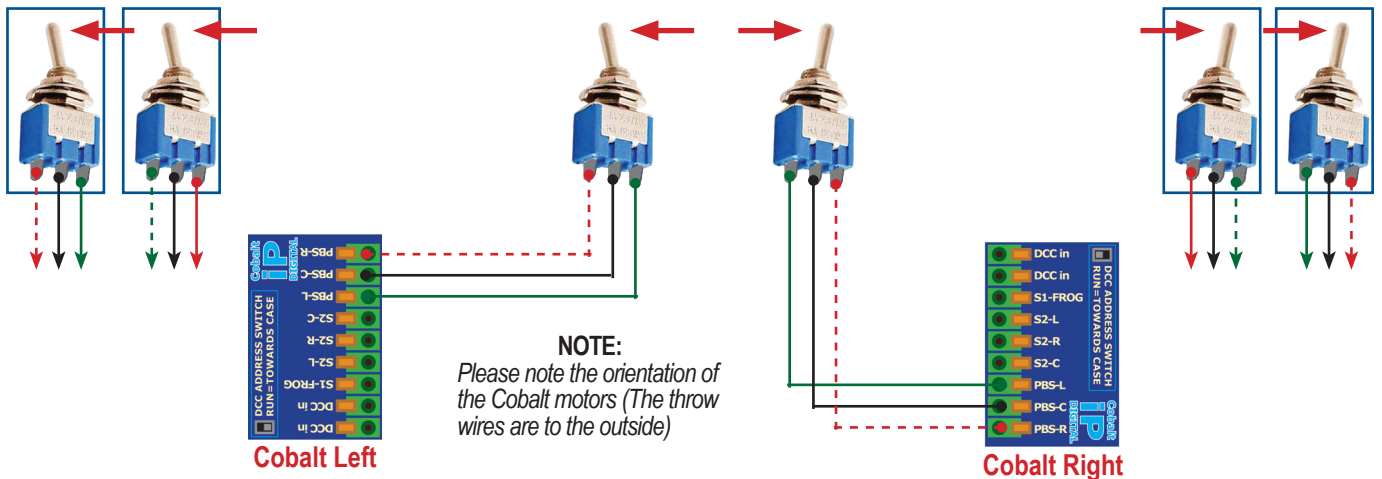

Unique features, real performance and exceptional installability

The DCD-BODC control module: Connecting the DCD-ABC control module & using the onboard header switches. Brake on DC has a simpler structure than ABC. Basic principles are the same for all uses, so just one diagram is needed here.

Wiring the DCD-ABC module - Connections.

- Connect the DCC BUS terminals to the DCC power bus (The DCC track power bus - see diagram below).
- Connect terminals T1 & T2 to the track power bus (keep the same red/black relationship as the DCC BUS wires)
- Connect the REMOTE terminals to any switch that can give you an on-off condition for the BODC board if desired.

Operating the DCD-BODC module - The header switches.

- To turn the BODC section on or off at the PCB level move the RED header.
- If you want to use an external SPST on/off switch to turn the BODC module on or off at will from the panel, connect it to the REMOTE terminals.
- To invert the BODC signal to change the STOP direction, move the BLUE header (Loco stops hen FWD or loco stops when in REV are the options)
- For automated control of the BODC board on/off condition, connect a Cobalt turnout motor switch, relay or similar device to the REMOTE terminals.

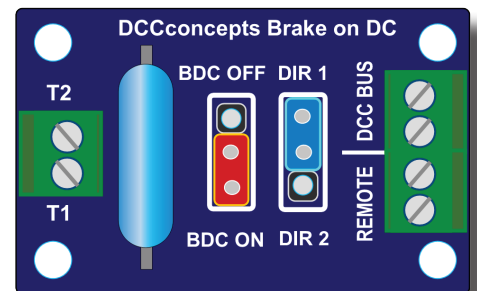

Example #1: Basic BODC use and connection, BODC stopping using one DCD-BODC module.

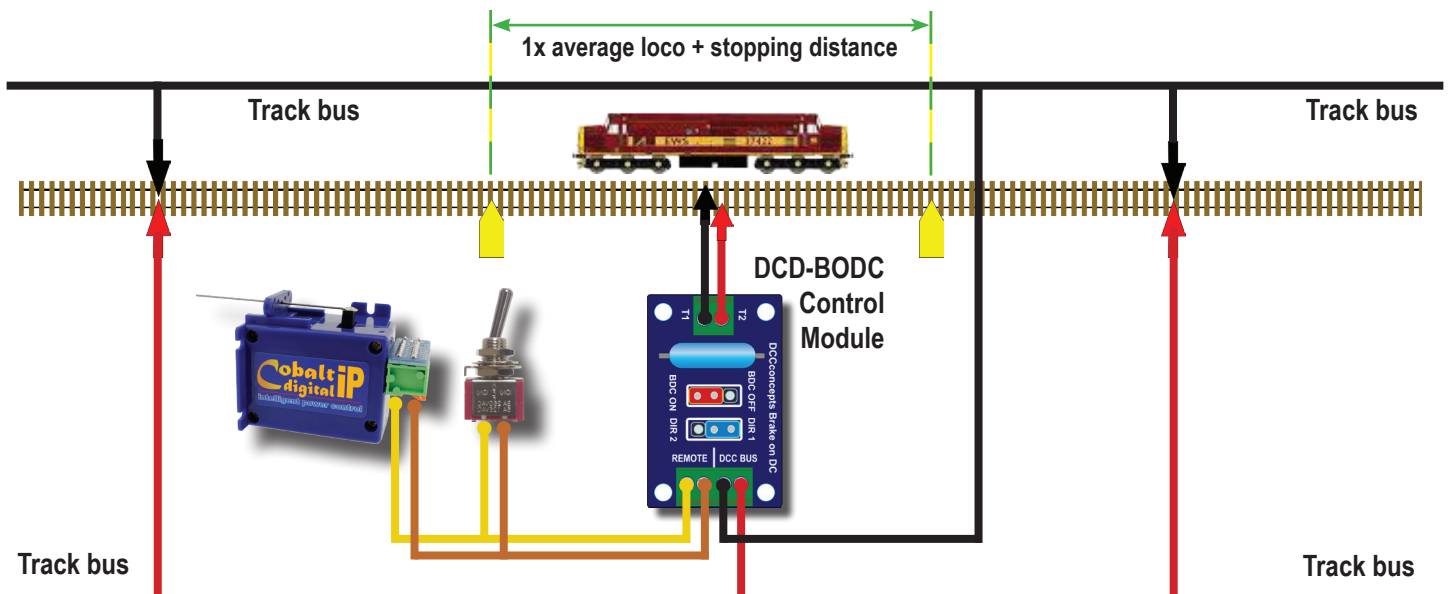

Learning about BODC - SETUP and CV changes to activate Advanced BODC for a single section

- Cut one rail, making the BODC stop section as long as 1 loco plus your preferred / planned braking distance (as above).
- Connect wiring and the DCD-BODC board to the test track as per this diagram.
- Set CV27 as per your choice in the chart below, and enjoy experimenting with Advanced Zen Brake on DC operation.

CV27=	Expected ZEN Advanced Brake on DC action if CV is set to that value	Related CVs
16	Advanced Brake on DC. Stop if BODC on, right rail more (+) , left more (-)	DC Running OFF
32	Advanced Brake on DC. Stop if BODC on, right rail more (-) , left more (+)	DC Running OFF
48	Advanced Brake on DC. Stop in either direction if the BODC unit is ON	DC Running OFF



Unique features, real performance and exceptional installability

ADDED NOTES:

As we continue to play with our ZEN decoders, we sometimes find things that we would like to add to the manuals.

This page will contain some further clarifications and tips on decoder use as we find them.

- Reversing out of an ABC section: To be able to simply press “reverse” and drive out of an active ABC section, the loco needs to have entered that section in forward. Therefore, please orient locos accordingly if using ABC.
- CV27 differences - ABC module reactions are always relative to forward or reverse with a locomotive if CV27 is set to 1 or 2. So, if you have CV27 set to 1 or 2 and you physically turn a loco around, you will need to swap the ABC module orientations too. However if CV27 = 3, then action will be bi-directional without ABC module change.
- Power interruption - if power is removed while the loco is stopped within an ABC stop section, then the loco can only be reversed out (REV on controller, not alternate direction) when power is restored. As a general guide, other than for stop sections at any terminus or stub ended yard, do not turn the layout off until all locos are properly stopped in a normal driving area of the layout.
- Do not use POM while a loco is in an ABC a slow or stop section. If you do it WILL be recorded by the decoder but the changes you make may not actually take effect until the loco enters a normal running track area.



Zen Decoders are imagined, designed and manufactured by DCCconcepts Ltd
Our showroom and offices are located in Settle, North Yorkshire BD24 9RP, England
Phone: +44 (0) 1729 821 080 * sales@dccconcepts.com * www.dccconcepts.com