

Cobalt

AD1 & AD4

dcc and dc compatible accessory decoders

We thought long and hard about the creation of our AD1 and AD4 accessory decoders...

Examining existing competitive products quickly showed that there was no shortage of clever products.

Most of those we tested worked reasonably well of course, but what we also found was over-complication, difficult set-up needs and hard to read manuals.

We also found remarkably low power handling among stall motor accessory decoders along with what were somewhat inconvenient programming methods needing addition of jumpers and the like.

Set-up often required complex programming & several otherwise nice products also had limitations on very desirable options such as the ability to have remote / DCC and easy local control with pushbuttons as well as other things that just made things harder than they needed to!

Our decision was therefore to create a stall-motor type accessory decoder that is built well, simple to understand, easily set-up, stable in operation and needing no complex wiring yet with versatility and flexibility of use.

We hope you will agree that the AD1 and AD4 meet our target and fulfil your need in the way you wanted!

So what's inside this manual?

We know that Cobalt point motors are being welcomed by both DC and DCC modellers so we have also made AD1 & AD4 both DC and DCC compatible.

Wiring and installing AD1 & AD4 really is so simple that even a novice modeller will find them easy to use, however they are also very flexible, so as with our Cobalt point motor manual, we have chosen to take the time to tell you not only how to set them up, but also how to use them in several ways that you may find useful.

Still need more help?

Try as we will we know that there will always be more questions than we thought of here and that sometimes, we will describe something in a way that is still not 100% clear to you..or perhaps still needs some more detail or qualification in relation to your specific layout.

If that happens, or if you have any questions at all about installation or operation possibilities, please feel free to telephone or e-mail us.

You can find us at: sales@dccconcepts.com and we will do our very best provide whatever help you need.

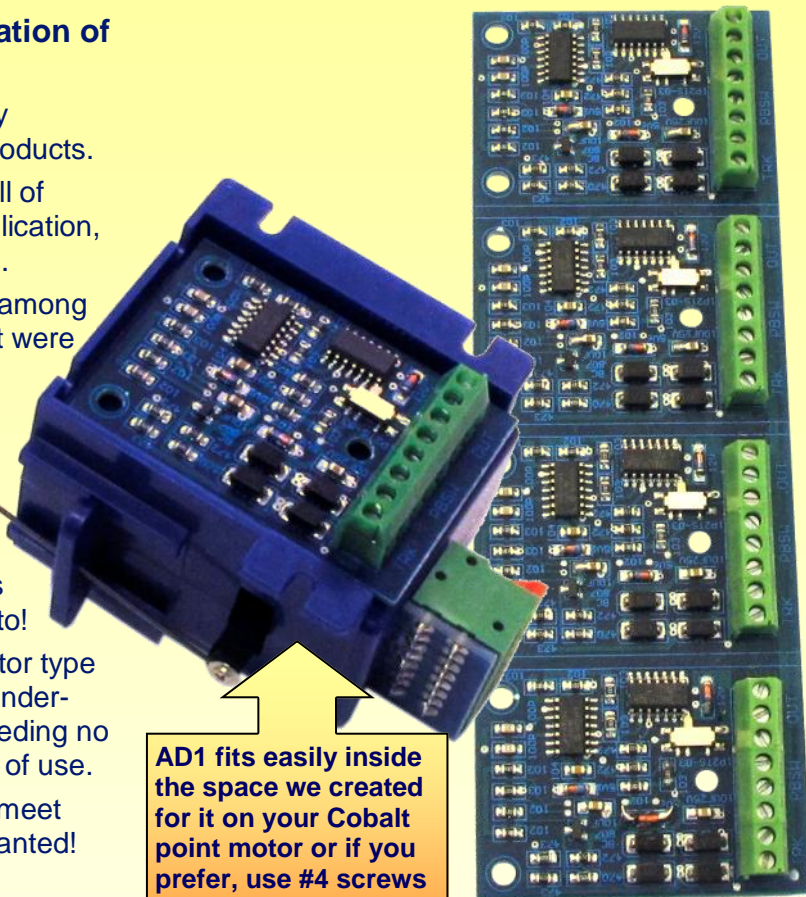

AD1 fits easily inside the space we created for it on your Cobalt point motor or if you prefer, use #4 screws or double sided tape to mount it anywhere you think suitable!

COBALT AD1 & AD4 MANUAL CONTENTS

- | | |
|---|---|
| 1 | Introduction |
| 2 | Specification, general information and features |
| 3 | Basic wiring information - AD1 |
| 4 | Basic wiring information - AD4 |
| 5 | Setting the address for AD1 and AD4 |
| 6 | Easy route control with AD1 and AD4 |
| 7 | Automation using AD1 & AD4 |
| 8 | Using AD1 and AD4 with DC layouts |
| 9 | <i>The Cobalt AD1 and AD4 Warranty</i> |

Modellers and model railway clubs are welcome to use this information for "own use" in any way they wish however no re-publication or web use of any kind is permitted without prior permission. Any appropriate commercial client use will always be acceptable with prior authorisation.

Cobalt AD1 & AD4

Specification and general user information

The DCCconcepts AD1 and AD4 Accessory decoders are easy to wire, simple to install, easy to program and versatile in operation.

*** Simple wiring:**

As few as four wires for an AD1 and one or two Cobalt, 10 wires for the 4-way AD4 are all that is needed. Add just two wires more per point motor, and you can have pushbutton control and a control panel as well as DCC control and automation!

*** Simple set-up:**

A simple switch puts Cobalt accessory decoders into learn mode, and once you have told it its address... one more click and its operational.

(For DC operation, there is NO address needed)

*** Simple Installation:**

AD1 fits conveniently into the recess on one side of your Cobalt point motor - Or if you prefer, you can fix it locally or anywhere you like with either #4 screws or double sided tape.

*** No special or heavy wire needed.**

Current draw is low so you can wire any AD1 or AD4 and its associated switches with relatively fine wire - 6 core 7x.02 alarm wire or even telephone cable is more than adequate, so neat and tidy wiring is easy, low cost and convenient.

*** No soldering at all.**

With self locking connectors on Cobalt and screw terminals on AD1 and AD4, wiring is quick, easy and should you want to change things, simple to undo and rearrange.

*** Higher power than others.**

Cobalt AD1 and AD4 can comfortably handle two Cobalt point motors per channel.

*** Easy automation without complication:**

You can now use those "macros" or "routes" that your NCE, Lenz, Digitrax, Gaugemaster or ESU ECOS can set-up with no added complications

You can also easily trigger operation of AD1 and AD4 with reed or treadle switches, detectors or indeed anything that will respond to the presence of a train or wheel - So you can easily automate Wyes & reverse loops for hands free operation!



Super easy to use

Slide switch for programming

* Up to operate

* Down to learn

(image shows the switch set to the operate position)

2 Wires to DCC Power Bus

2 Wires to Momentary Pushbutton SW

2 Wires to the Point motor/motors (can control 2 easily)

Ad1 and adAd4 facts & specifications

W x H x D	Length AD1 34.5mm AD4 142.5mm (Overall)	Width AD1 50mm AD4 50mm (Overall)	Height AD1 10mm AD4 10mm (to bottom of PCB)
Approvals	AD1 & AD4 meet all valid CE/ROHS/NMRA Standards		
Power Input	Direct from the DCC booster/track output <u>or</u> 12v DC		
Output voltage	Appx 9.5 V DC with NMRA standard DCC track voltage		
Address range	AD1 and AD4 support addresses between 1 and 2044		
Program method	Onboard switch to enter program mode. Program while connected to track bus only. Both AD1 and AD4 can be programmed quickly and easily by any DCC system with the ability to control Accessories. Please note that with AD4 all 4 decoders are programmed independently		
Control methods	Via DCC system handset, trigger via detector or similar devices, computer system software and either single <u>or</u> multiple pushbutton switches. AD1 and AD4 both also work well on DC power with pushbutton switches.		
Connections for AD1 decoder	Easy to use solder-free screw terminals. With terminal strip facing you, 1+2 are track/Bus power, 4+5 are pushbutton connections and 7+8 are connections to point motor(s). Terminals 3+6 are not used at any time.		
Connections for AD4 decoder	Connections are exactly as per the AD1 however you will only need to make ONE connection from terminals 1+2 to the track bus to power all 4 decoder units		
Current Draw	AD1 and AD4 draw zero current unless operated - then current drawn is 21~22mA <u>including</u> Cobalt point motor. Maximum safe continuous load on each output is 80mA		
Mounting options	AD1 can easily be mounted directly into the specially created recess in your Cobalt point motor using Double sided foam tape. Alternately we have provided 3 x 3mm mounting holes in each decoder for # 4 screws. We have ensured a clear copper area around each screw head for safe installation without washers. If possible use "stand-offs". Please do not over-tighten.		

Cobalt ad1~ad4 Address change is as easy as it can be. Just set the slide switch to program & set it back to operate!

Cobalt AD1 & AD4

Best practice for AD1 & AD4 wiring

(A) Best practice for DCC accessory wiring:

For smaller layouts, simply using track power for low power accessories such as turnout/point motor decoders designed for stall motor devices like Cobalt is fine... but::

As the layout grows and complexity increases, so does the power requirement, and all of the added devices will start to also affect the integrity of the DCC signal or wave-form so we strongly recommend that you consider establishing a second power bus just for accessories at the very start.

Its not complicated - Just a duplication of the track bus.

- Initially, its enough to simply branch off at the controller end and run two sets of the correct weight twin wire for track and accessory bus power.
- As a "next step", add a separate overload protection device for the accessory bus and track bus. That way if you have a derailment or problem that shorts the main, your accessory bus will still be "live" and you can still change turnouts/points etc.
- Finally, as the layout grows larger and more complicated with lots of DCC controlled accessories, you should consider adding a separate power booster.

- If the LEDs light wrongly in relation to the Turnout position, reverse the orientation of the LED connections in relation to the lead they are in series with.
- Now when you reverse polarity, one LED will light, the other will not, indicating turnout position clearly.
- TIP: If you use 4 or 6 wire alarm wire between decoder /LED/switches and control panel it will give you consistently colour coded wiring all in one tidy cable! Alarm wire is low cost too!**

Diagram for (A)

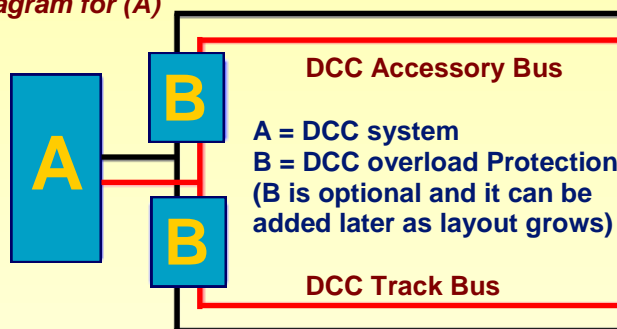

WIRING AD1 (AD4 is on the next page)

(B) Wiring AD1 to a Cobalt turnout motor:

This is simplicity itself. No soldering needed either!

You will need just 4 wires for DCC control, 6 if you want to install a control panel with switches too!

- Connect 2 wires from the power bus or track to the 2 "TRK" terminals of AD1.
- Connect 2 wires from the "OUT" terminals of AD1 to the 2 motor drive terminals of the turnout motor.
- If you want manual as well as DCC control, connect 2 wires from the PBSW terminals to any standard low cost power ,momentary pushbutton switch.

PS: Yes, you can connect two point motors to ONE AD1 so that 1 x AD1 accessory decoder controls a crossover.

(C) Adding LED panel lights the easy way:

Because Cobalt and similar DC powered turnout motors are finally controlled via a reversing DC voltage, we can use this to our advantage and easily install LED indicators.

- For this all you'll need are 2 LEDs of any colour you prefer. No resistors will be required for any colour.
- Wire the two LEDs so the (+) of one is connected to the (-) of the other, then wire these combined LED leads in series with one wire from the AD1 or 4 to one side of the turnout motor.

Diagram for (B)

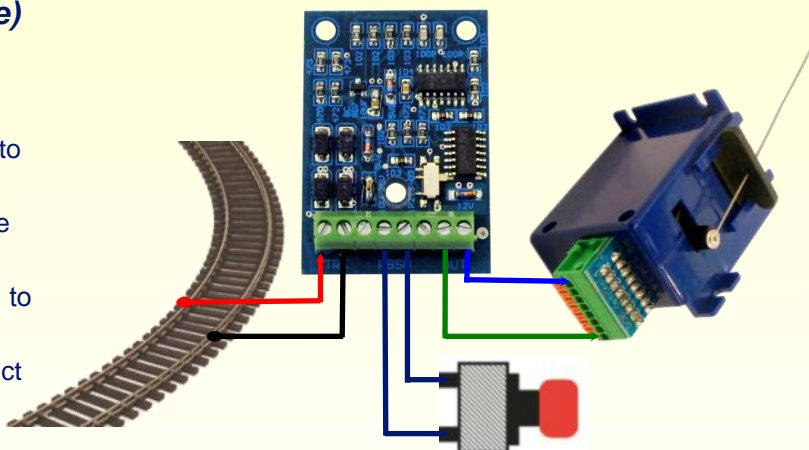
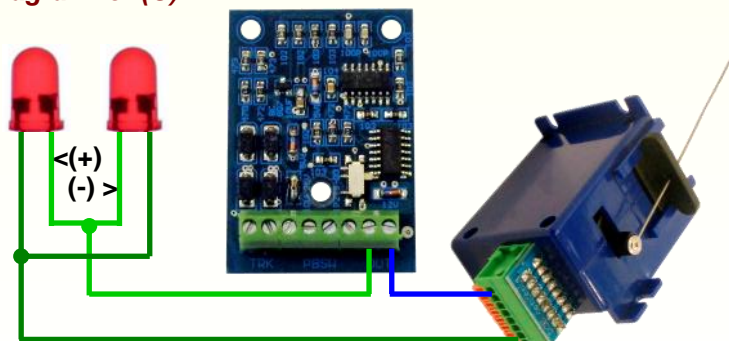

Diagram for (C)



Cobalt

AD1 & AD4

Best practice for AD1 & AD4 wiring

WIRING the Cobalt AD4 4 way accessory decoder

We really did mean it when we said we wanted to keep it as easy as we could for you, so apart from one small exception, the AD4 is identical to AD1 in all respects.

That one difference is very simple: While we have still provided a pair of power input (TRK) terminals for each individual accessory decoder on an AD4, you only need to add power wires to ONE and all will receive power.

(A) Wiring AD4 to track or accessory bus:

Choose whichever pair of TRK terminals on AD4 are the most convenient for you and connect these to the track or accessory bus. You only need to connect ONE pair.

(B) Wiring AD4 to a Cobalt turnout motor:

Please treat each accessory decoder as individual and wire exactly as per the AD1 instructions. A single decoder output can easily handle both motors in a crossover.

(C) Adding LED panel lights the easy way:

Please treat each accessory decoder as individual and wire exactly as per the AD1 instructions.

An alternate way to wire LEDs as panel indicators

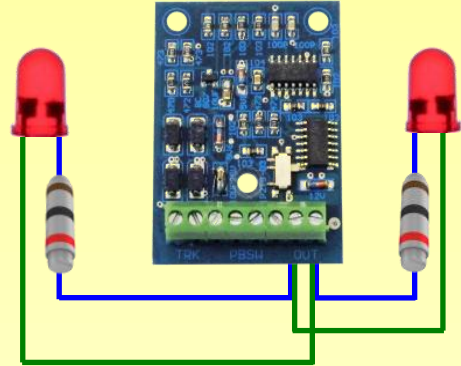

EXPERT TIP: We have found that it's best to set the address for your AD1/AD4 accessory decoders before adding pushbuttons. If you do install pushbuttons before programming and you find that the buttons do not respond properly, don't worry: Just re-set the AD1/AD4 address & everything will work as it should.

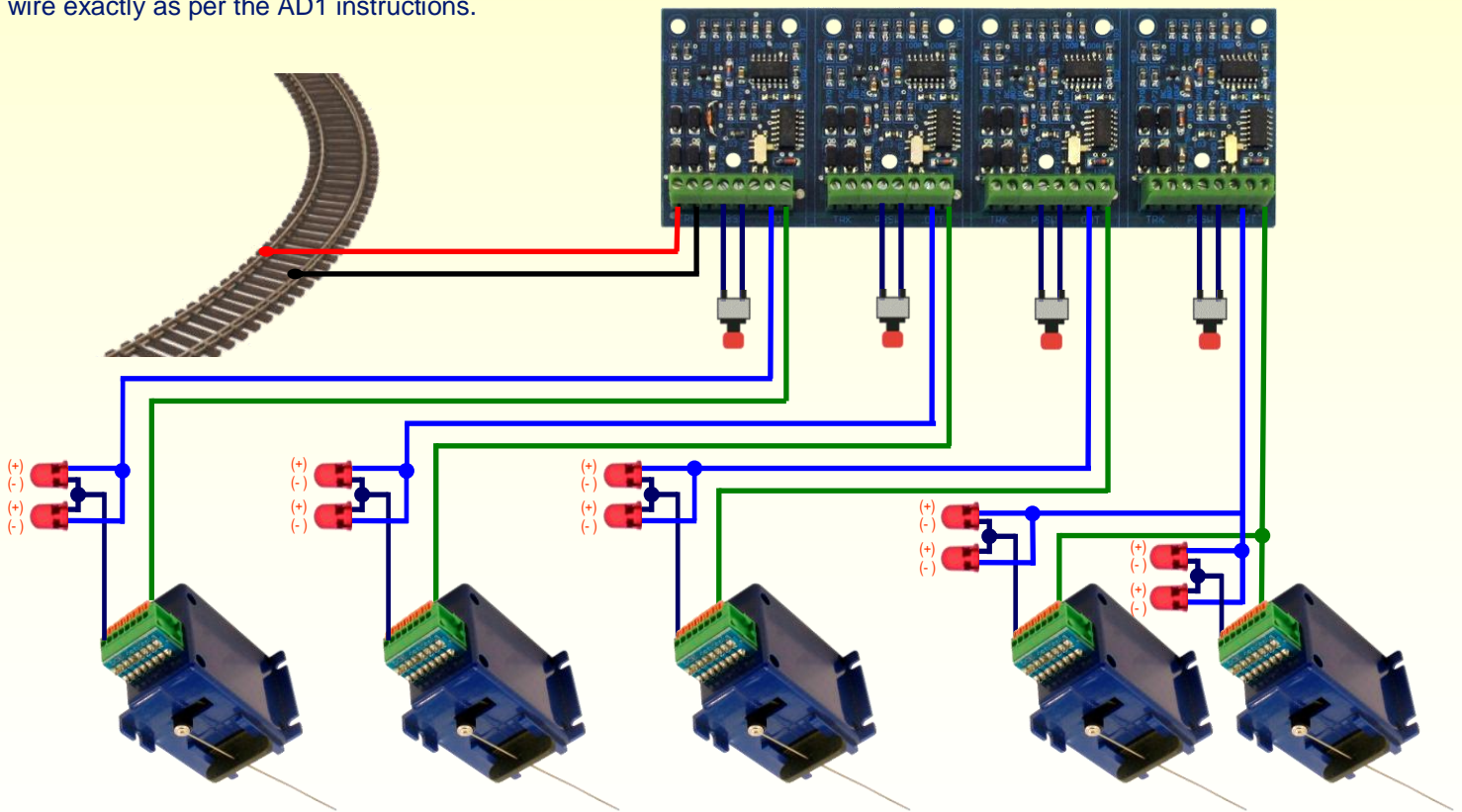

You can see how super-easy it is to add 2 or more control panel LEDs per point motor with almost no extra effort at all!

These two form a crossover and both are powered from ONE output on the AD4

Cobalt AD1 & AD4

Setting the address of AD1 and AD4

The DCCconcepts Cobalt AD1 and AD4 accessory decoders really are easier, simpler and quicker to set up than ANY other Accessory decoder available. With most DCC systems, it takes only 4 or 5 button pushes to teach our accessory decoders their address!

Setting the address / programming method (DCC only - Not required for DC use)

AD1 and AD4 do not need ANY form of CV setting or complex programming at all in order to set their address and all set-up and operation is done while they are connected to the track, track bus or accessory bus.

AD1 and AD4 have been created to be compatible with all relevant NMRA DCC standards and can be set-up quickly and easily and will perform reliably with any DCC system which is capable of operating an accessory decoder.

Putting your AD1 or AD4 accessory decoders in & out of "Learn" mode

Your AD1 or AD4 decoder will need to be connected to DCC track power before you can teach it a new address. Please refer to the photograph to the right.

You will see a small silver slide switch with a white "flag" close to the screw terminal strip on the lower right hand side. This switch is used to enable "learning" mode on each AD1 and on each individual decoder of an AD4.

To put the decoder in "learn" mode use the tip of a pen or similar item to slide the switch towards the terminal strip.

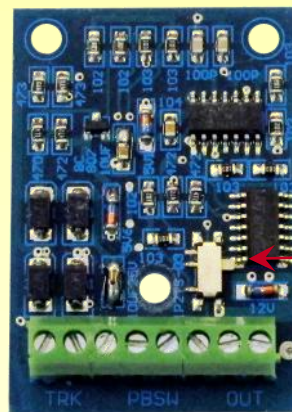

Accepts any address from 1 to 2044 as per standards

Super easy to use
Slide switch for programming

- * Up to operate
- * Down to learn

(image shows the switch set to the operate position)

Once the decoder has been told its address, just return the switch to its upper position and it will now respond to the address which you entered. You can of course set and reset the address as often as you wish.

Setting the address with NCE systems:

- Move the AD1/AD4 switch to the "learn" position.
- Press "SEL ACCY"
- Enter the number you want it to respond to in future
- Press "Enter"
- Press 1 or 2
- Move the AD1 / AD4 switch to the "Run" position and the decoder will now remember its address.

Setting the address with LENZ systems:

- Move the AD1/AD4 switch to the "learn" position.
- Press "F" Then press *5"
- Enter the number you want it to respond to in future
- Press "*" (Asterisk)
- Move the AD1 / AD4 switch to the "Run" position and the decoder will now remember its address.

Setting the address with Digitrax systems:

- Move the AD1/AD4 switch to the "learn" position.
- Press "SWCH"
- Enter the number you want it to respond to in future.
- Press "OPTN"
- Move the AD1 / AD4 switch to the "Run" position and the decoder will now remember its address.

Setting the address with ESU systems:

- Refer to ECOS manual—page 22 for 50200 colour ECOS or page 11 of the ESU navigator manual.
- Enter the turnout in the ESU database as required
- Place the AD1 or AD4 into learn mode
- Operate the required turnout number
- Move the AD1 / AD4 switch to the "Run" position and the decoder will now remember its address.

Setting the address with MRC/Gaugemaster Prodigy Advance systems

- Press "ACCY" then Enter the number that you want the decoder to respond to in future
- Press "Enter" then press 1 or 2 as if you are changing the turnout or operating the accessory.
- Move the AD1 / AD4 switch back to the "Run" position and the decoder will now remember its address.

Always use this approach to setting the address - you cannot use CV programming with the AD1 or AD4.

Cobalt ad1~ad4 How easy can it get? Just 4 wires & about 6 button pushes are all that's needed to be ready to go!

Cobalt AD1 & AD4

Route control is built into your DCC System

We are asked VERY often about yard automation or the switching of yard ladders without the need for individual control of turnouts, especially where these may be hidden storage areas.

Did you know that easy and simple to use DCC Route Control is already built into your DCC system?

Well in most cases it is... and once you add our Cobalt point motor and Cobalt AD1 and AD4 accessory decoders it will be possible for you to create and control entire complex routes & track junctions with just the push of a control system button or two and there will be NO need for additional complex wiring, switching, or a diode matrix or computer system!

Previously, because commonly used high current solenoids easily overload the sequential reaction ability of DCC accessory decoders and totally overwhelm the ability of even larger power supplies which cannot switch several solenoids in very quick succession, this ability has had to remain unused... but now thanks to Cobalt and the Cobalt AD1 and AD4 you can at last unlock this advantage of DCC control! This is made possible by two factors.

- (1) Cobalt is a low current stall-motor device that needs almost no power to change consistently and reliably.
- (2) AD1 & AD4 accessory decoders have an active memory, so they receive commands as fast as your DCC system can spit them out... acting on them in the correct order when they are ready to do so for totally reliable results.

There are also ways to make it very economical.... For example, both ends of a loop can be controlled by 1 decoder. (There's no need to do any preparation for this other than installing and addressing the AD1 and AD4 decoders)

The following brands can all set up and operate routes with no need to add anything to the system other than accessory decoders like AD1 and AD4 that are able to remember and operate when ready to act on a group of commands sent out in a fraction of a second. Please check your owners manuals to see how its done, and to find out how many steps each route may have, and how many routes your controller will be able to store.

ESU ECOS and Navigator, Bachmann Dynamis, Digitrax, NCE, Lenz, Zimo, Uhlenbrock

(Other brands may well be able to do or route control however we have included only those we're sure of here)

We can't include examples using all of the above brands here as we do not have the space - but if you use NCE PowerPro or PowerCab, here is how you can do it with your DCC system.

Setting up routes with NCE systems: (NCE calls them "Macro's")

- Press MACRO then Press 8 followed by ENTER - The screen will now show 1= PROG 2 = REVIEW - Press 1
- Enter the number you wish to give to this route (Macro) and then press ENTER
- Enter the number of the first accessory decoder/turnout to change and press ENTER
- Press 1 or 2 depending on which way you want that turnout to throw
- Enter the number of the next accessory decoder/turnout to change and press ENTER
- Press 1 or 2 depending on which way you want that turnout to throw

Repeat as above for each accessory decoder/change that is wanted. When all are entered, press ENTER straight after the last throw selection and the screen will now show 1= PROG 2 = REVIEW again. You can now either press "REVIEW" and step through the route to check it or just press ENTER and be back at the standard control screen.

Operating the Route you just created:

- Press MACRO and then simply enter the number that you allocated to that macro/route.

That's all there is to it.... NCE can, by the way, store 16 routes each 8 steps long with PowerCab and 256 routes each 10 steps long with the Power-House Pro system. Routes/Macros can be daisy chained for very complex route control.

Using Macros or Route control you can change every turnout from 1 to 7 to set the RED route by pressing only 2 buttons on your DCC systems controller or handset!

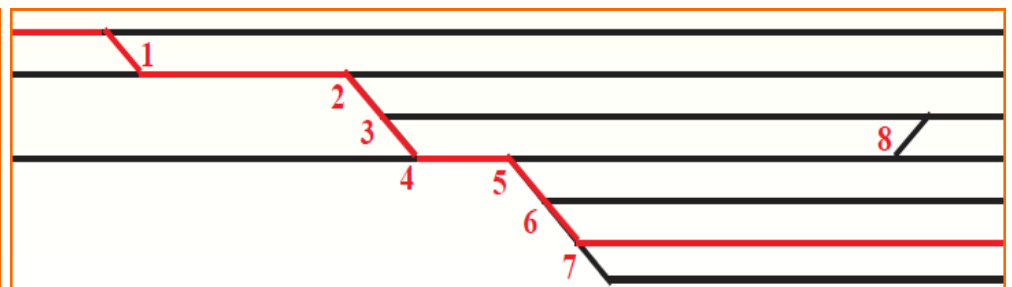

Cobalt ad1~ad4 How easy can it get? Just 4 wires & about 6 button pushes are all that's needed to be ready to go!

Cobalt AD1 & AD4

Easy Automation using AD1 and AD4

In addition to direct switch control on DC and switch or direct system control and automation/route control with DCC or computer systems, AD1 and AD4 are also easy to operate automatically using ANY form of detector and ANY form of momentary switching that you might choose to adopt for use on your layout.

AD1 and AD4 will work equally well with DC power or DCC layouts and do not care whether detectors use an active voltage or simple impedance change at their outputs.

Because the AD1 and AD4 switching terminals “toggle” in response to changed voltage or impedance, DC modellers can easily control track related and direction-critical automation by adding a simple diode to allow track switches to conduct only with trains travelling in one direction.

Modellers using computer or DCC system linked commands as output responses from decoders can, in addition to using the switch terminals as direct commands, also at the same time combine automated route control or other automation routines that give specific directional response instructions as required via the track bus input terminals.

AD1 and AD4 can comfortably be driven directly from a micro-switch or a detector or via a relay switched by a detector. They will also respond to signal decoders whether momentary or latching.

All you need do is to connect switch terminals 4 and 5 to the device that you wish to use for control.

Remember too... Each AD1 / AD4 is controlling a COBALT point motor which has another two SPDT changeover switches available, so if you wish to change signals or other accessories at the same time as activating AD1/4 and Cobalt, you can easily do so via Cobalt's built-in switching.

Have fun with them - and don't be afraid to experiment!

Which wire to use with Cobalt AD1 and AD4?

Because both Cobalt point motors and Cobalt AD1 and AD4 are low power devices, heavier wire really isn't needed. You can therefore use finer easy to handle wire as small as 7 x 0.2mm (22~24 gauge) if you wish.

Most often when we wire them we use 4 or 6 wires....

Our favourite wire for this is either 4 or 6 wire alarm installation wire... We like this wire as it is the ideal gauge of copper, already consistently colour coded and has a nice white cover that we can write on to designate where its from. It is low cost too!

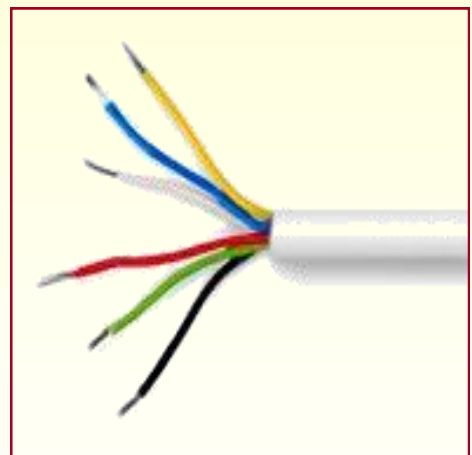

Mounting AD1 and AD4

- (1) Double sided tape works fine. You don't need much but please use a quality tape such as 3M as cheap tape may have acidic adhesive which is not good for circuit boards.
- (2) We've provided 3mm holes in both AD1 and AD4 and made sure that a screw head will not touch PCB tracks.- Use pan head screws and do not over-tighten. We recommend that you use plastic stand-offs if possible. These are simply plastic tubes that keep the PCB above the mounting surface. Available at low cost from electronics parts stores.

Cobalt AD1 & AD4

Using AD1 & AD4 on DC layouts

DC wiring just doesn't get any easier!

An AD1/AD4 DC or DCC decoder, a 12v DC plug pack, two power wires, two wires to a momentary pushbutton switch & two LEDs for control panel indication set back-to-back in one of the two wires from the decoder to the point motor.

No, its not the lowest cost option for wiring points on a DC layout but the accessory decoders are a very reasonable price and when you also add up the OTHER savings you will make, its certainly not expensive either!

Think about it... No need for an expensive high power transformer, no need for a capacitor discharge unit, no need for expensive and hard to adjust added switching on solenoids, you can use light wire instead of heavy and only about 1/5th as much is needed, NO under-baseboard soldering needed - in fact almost no soldering at all apart from switches and LEDs for the panel.

You will also cut wiring time by more than 75%, make installation and wiring MUCH easier... increasing reliability at the same time!

AND of course there is one more advantage: your layout will be totally ready for DCC in the future, as you will need to change nothing at all when you convert to DCC control.

THERE IS NO NEED TO SET AN ADDRESS WHEN USING DC POWER

12 volts DC Regulated Power supply
(1 amp wall type is ok as that is enough for 40+ Cobalt motors)

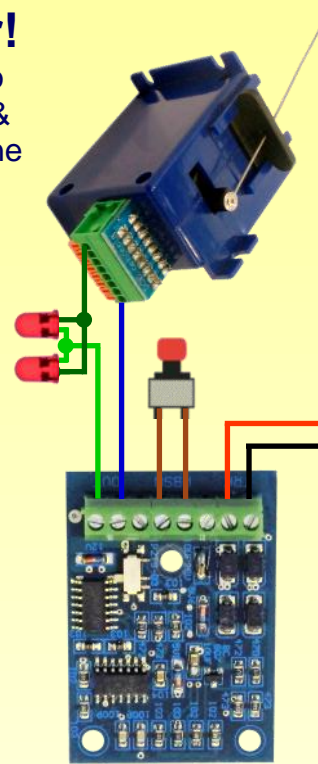

Look carefully at the AD4 wiring diagram to the left of this text:
See what we mean? It really is a huge advantage using AD1 or AD4 as even though you have full panel control and LED indicators on the control panel, only 2 wires ever need to go out and under the layout to power the point motors and even those will need NO soldering thanks to the smart solder-free connections that we chose to fit to Cobalt!

12 volts DC Regulated Power supply
(1 amp wall type is ok as that is enough for 40+ Cobalt motors)

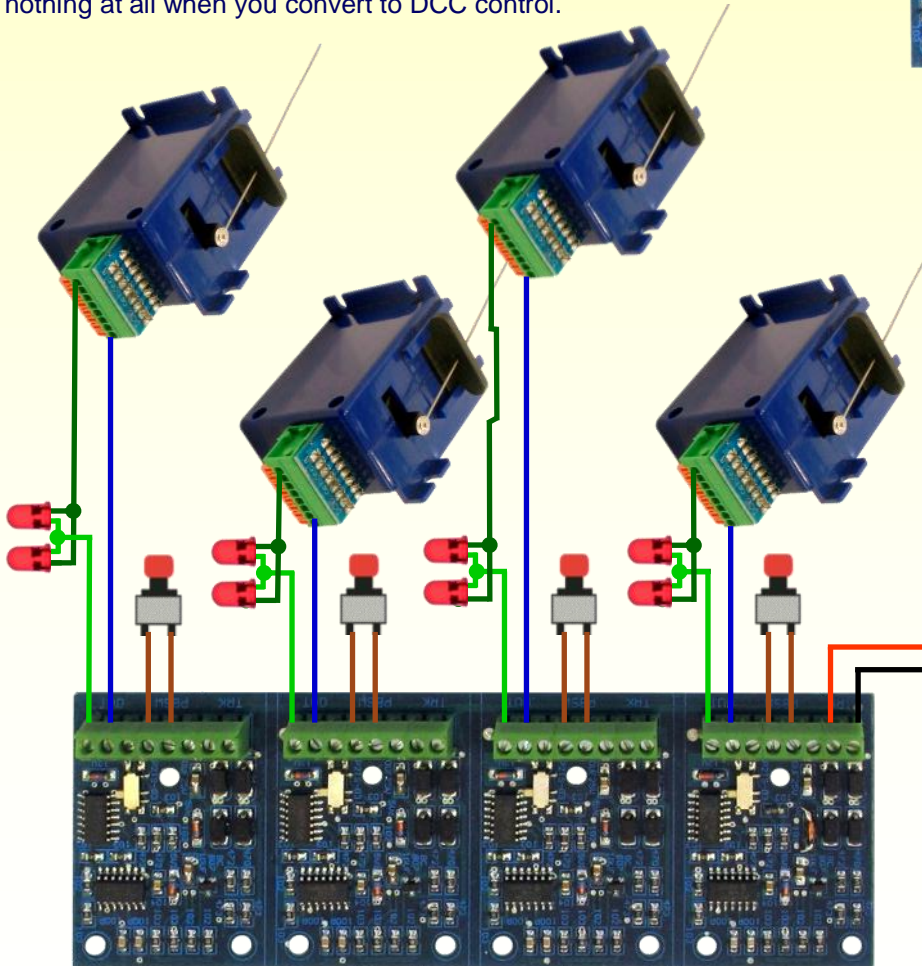

Coming Soon... AD4PK - A pack of 4 normally off SPST momentary push button switches with optional red, green and black colour caps & 8 Red / 8 Green LEDs

The Warranty

Cobalt ad1 & ad4

As with all of our products, we have chosen the very best materials and taken great care with design, testing and quality control, with a high level of in-manufacture and pre-packing tests.

This, plus the use of only the most modern equipment and quality parts means that reliability is built into every ad1 and AD4 we make, so we are happy to offer you a warranty that reflects that quality.

The Warranty... Simple, fair and clearly stated in plain English.

(This Warranty is not transferrable and applies only to original owners who purchase their Cobalt AD1 and AD4 accessory decoders from an authorised stockist).

Having designed them to last, we are pleased to offer Cobalt AD1 and AD4 accessory decoder owners a 1 year warranty and 1 year part exchange guarantee when they are installed & used in accordance with the instructions provided here & on the packaging, on an indoor model railway, in any scale.

The warranty and 2nd year guarantee apply when the AD1 and AD4 are used in any reasonable application as a device for automation of any brand of low current stall motor type point motor, whether it is used for turnout control, automation of other accessories or signals or any other appropriate use.

The warranty and 2nd year guarantee apply providing that your AD1 or AD4 has been installed and used with respect for its power handling and is mounted so that it will not be exposed or subjected to water or corrosive liquids, has been properly wired in accordance with these instructions, operated within recommended supply voltages and power has been supplied to it by an NMRA compatible DCC control system without put voltages within the specified range or a stable 12 DC power source.

The first year after purchase....

If your Cobalt AD1 or AD4 or any part of it fails under any fair and reasonable operating conditions within 12 months of purchase please return it to your retailer along with a copy of purchase receipt.

If returning by mail (or enquiring by E-mail) include a description of the installation and how it failed.

Providing that examination proves that the failure was not due to physical abuse, water or similar damage, over-voltage or excessive current loading on switch contacts, your retailer is authorised to make this decision locally without further reference to DCCconcepts and so once warranty cover is agreed you will promptly receive a new Cobalt turnout motor from your retailer free of charge.

In case of uncertainty: *If your retailer is unsure of any issue relating to the failure he may choose to refer the claim to us at DCCconcepts Pty Ltd along with your contact information and in that case we will promptly assess the failure and if warranted, supply your replacement directly from our offices.*

For the following year....

If your Cobalt AD1 or AD4 or any part of it fails under what are reasonable operating conditions at any time after the initial 12 months of purchase, please contact DCCconcepts Pty Ltd directly, advising us of the circumstances and possible cause of the failure (if known).

Once the required description of the failure and other required information has been received (including proof of purchase) we will then decide whether or not to ask you to return it for evaluation.

As sophisticated electronic items AD1 and AD4 are not always economically repairable so we will provide you with a replacement product at part cost.

The replacement cost will already include airmail postage and it will be accepted via credit card only.

Within Australia: AD1 - \$8

AD4 - \$25

Outside Australia: AD1 - \$10

AD4 - \$27