

Cobalt

Turnout control redefined

Installation instructions: Easy offset mounting for awkward places.

If there is a need to offset the mounting of your Cobalt turnout motor due to baseboard beams etc in the way, then try this... this method will work even if there is a beam directly under the tie bar of the turnout.

You will need the following materials in addition to the Cobalt Turnout motor.

- (1) Brass tube with an internal diameter of approximately 0.8~0.9mm
- (2) Spring steel wire . We use 0.8mm but a little either way is fine. Spring steel wire is low cost and usually available at hobby shops, (especially those who sell flying models as it is also used for undercarriages)

You will need the following common hobby tools.

- (1) A razor saw or heavy disposable knife blade to cut the tube (cut with a knife by pressing down firmly and rolling back and forth)
- (2) A drill the same size as the outer diameter of the tube - probably 1.0 to 1.1mm.
- (3) A cut off wheel or hardened cutters for the spring steel wire (Or you can file a nick either side of the wire at the cut point and break)
- (4) Solder, flux & soldering Iron OR a good strong easy to control glue. (Loctite also works as it is steel wire)

Parts reparation:

Cut the following from the brass tube.

- (1) Two short lengths, each about 3~4mm (not critical). Clean them up after cutting to remove any ragged edges.
- (2) One length about 15mm. Mark 5mm from its end and squash the 5mm end flat. Mark the centre of the flat section and drill a 0.8~0.9mm hole close to the end.
- (3) One piece that is the total of the length needed to be flush with the top of the sleepers (ties) and also extend 8~10mm below the baseboard.

Cut a length of the spring wire.

Its total length should be 55~65mm PLUS the length of the brass tube in 3 above.

Prepare the turnout area.

Look for the hole in the tie bar and measure 10mm from that hole parallel to the track... Orientation towards the toe OR heel of the turnout is OK, but make sure that the hole misses the baseboard beam that is in the way. It's OK to adjust length in order to allow for sleepers (ties). Use a drill bit that is the same diameter as the brass tube so that it will be a smooth sliding fit.

Check that the hole clears the beam then insert the tube and glue it in place flush with the sleeper (Tie) tops.

Prepare the spring wire.

Mark 3mm from the end, bend sharply to 90 degrees.

Place this 3mm end into the tie bar hole and mark the point where it passes over the brass tube you glued into the hole. Be sure this is right then bend at a sharp 90 degrees.

Insert the spring wire:

You should now be able to insert the long end of the spring steel wire into the brass tube with the 3mm end dropping into the hole in the tie-bar. If not, take the time to remake it until it does (spring steel wire is low cost so its worth persisting to get it right).

With the 3mm end in the tie bar and the rest inserted into the

Hold the wire down firmly on the tube top, grip the free end of the spring steel wire under the baseboard close to the brass tube and bend at 90 degrees so it points directly away from the beam that caused the problem.

You now have a crank that, when moved left & right from below the baseboard, will move the turnout tie bar for you.

Add the flattened brass tube to complete the crank:

Take the tube with the flat section and slip it onto the end of the crank. Solder/glue in place with the flat part horizontal.

Preparing Cobalt for installation:

Using a 9v battery or power supply, centre the Cobalt actuator wire. Temporarily put the wire in its mount hole in the actuator bar and mark it at a point about 2mm below the top mounting surface . Cut the actuator wire at the mark

Take ONE of the two short lengths and solder or glue it 6mm from the top of the actuator wire, then re-insert into its hole and add the retaining screw.

Orient the Cobalt fulcrum bar so that the holes are at the bottom and with the actuator wire inserted into the centre hole, slip it into its guides. Add a Cobalt foam pad or double sided tape to the top of Cobalt.

Final installation:

Centre the tie bar and hold in position with tape or thin packers. The actuator wire of Cobalt should be centred, with the fulcrum bar placed about half way between top and bottom in its guides.

Place Cobalt with it facing the end of the crank wire, and thread the Cobalt actuator wire through the hole in the flattened brass tube that is on the crank wire. Secure Cobalt temporarily with the foam tape only and then add the other short length of brass tube at the tip of the actuator wire to secure the crank properly.

Test, moving Cobalt's fulcrum bar up or down until the turnout works reliably. When all is well, screw Cobalt in place.

This diagram should explain it all clearly:

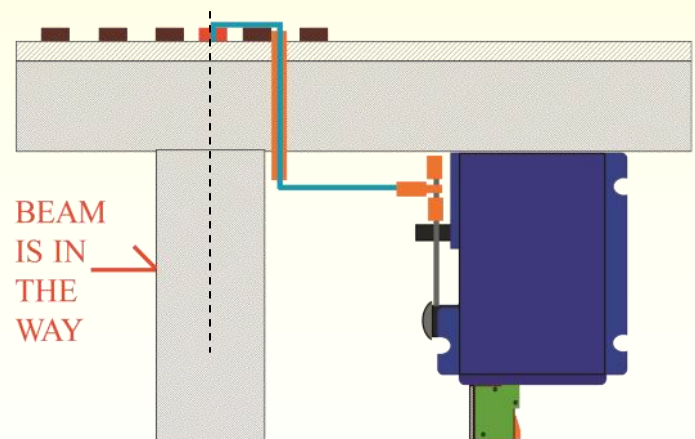

Legend for drawing:

- | | |
|---------|-------------------|
| Red : | Tie Bar |
| Orange: | Brass tube parts |
| Cyan: | Spring steel wire |