

Cobalt AD-S8fx Solenoid Decoders

(Also applicable to AD-s2fx)

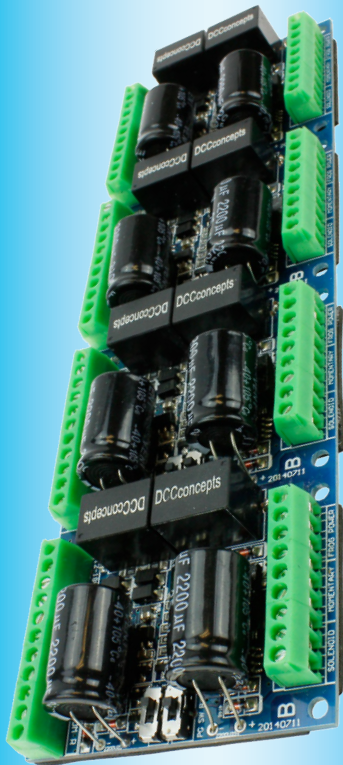

OWNERS
MANUAL

Overview: Cobalt AD-S8fx Decoders

The perfect way to change solenoids on DC or DCC layouts

Please be sure to read these instructions before installing your AD-S8fx Decoder. DCCconcepts AD-S8fx decoders have been designed from the outset to work perfectly on both DC & DCC controlled layouts and each output is able to reliably change two Peco, seep, Hornby, or similar point motors simultaneously.

AD-S8fx Decoders can be connected directly to DCC track power or a DCC accessory power bus and need no added power supply or wiring when used with DCC (15v DC is required for DC layouts).

Unlike other brand Accessory decoders which run out of energy, AD-S8fx decoders are able to reliably fire all outputs at once (for Route control, Diode matrix control, Macro or Computer control) as each individual output stores all the power it needs on-board.

AD-S8fx decoders always remain ready to do whatever you wish reliably every time, without draining available DCC track power.

Power use is intelligently managed on-board, so you don't need a big power supply even when used on DC layouts - Any regulated 15v DC supply that can deliver about 1.5 amps should be just fine!

AD-S8fx also has some exclusive added features:

AD-S8fx also has all the features that solenoid users could wish for:

- * Frog polarity control for live frog (electrofrog) pointwork.
- * LED outputs ready for you to add lights to your control panel.
- * Dual momentary contact switch option so you can have both digital & manual control of your points - switching contacts are triggerable with hall, diode matrix or detectors for automation.

Overview: Cobalt AD-S8fx Connection

DCCconcepts AD-S8fx decoders have screw terminals for most common connections to make wiring easier for you. The use of all terminals is also marked clearly on the PCB. The LEDs however do need soldering. The LED solder pads are underneath the PCB. Please do NOT tin the wire ends when using screw connectors - it is less reliable long term. Just strip the wires carefully and twist them tightly.

We recommend the following wire choices for AD-S8fx.

- (1) Solenoid wiring: DCCconcepts 32x0.2 3-plait solenoid wire. (if not available, please use 32x0.2 wire if possible, 16x0.2 minimum for shorter runs (Plait it too. Plaited wire is neat and tidy. Plaiting also helps the decoder manage voltage spikes created when a solenoid operates).
- (2) Switch, LED & IO wiring: 7x0.2 to 16x 0.2 is OK (light wire is OK). (Your choice may be different depending on where you put your AD-S8fx decoders, however 6-core alarm wire can be an excellent choice as it gives you 3 wires for switches and 3 more LED etc in one tidy cable).
- (3) Frog Wiring: 16x 0.2 or even 7x 0.2 are OK (Dropper wire sizes). (Please keep frog power wires as short as possible. We suggest you adopt a consistent colour for frog wires - green is the usual choice).

AD-S8fx has all wiring positions clearly marked on the PCB. Before wiring your AD-S8fx decoder please read these instructions from start to finish and then take note of the following advice:

* Plan your wiring colour codes. A little forethought makes it much easier to maintain your layout as time goes on.

* Because the LED connections are UNDER the PCB, you will need to complete wiring for the LEDs before fixing the AD-S8fx in place.

Important: AD-S8fx has a high power CDU on each of its outputs. Allowing the lower face of the PCB to contact conductive areas, metal tools, etc. will cause serious damage to on-board electronics.

Overview: Cobalt AD-S8fx Connection

(Continued)

- * Make sure your soldering iron is ESD safe. A soldering iron with voltage or mains leakage at the tip can be very dangerous AND it will cause damage to the AD-S8fx electronic circuits.
- * Make sure your mounting or work surface is clean. Also make sure it is clear of metal objects that can cause accidental short circuits.
- * Make sure layout power is turned off before connecting AD-S8fx.
- * The LED outputs do need soldering. Therefore it may be easier for you to pre-wire them before installing the AD-S8fx into its final position.

Overview: Cobalt AD-S8fx Connection

DCCconcepts AD-S8fx Solenoid decoder connection structure.

- * For clarity, we show only one 2-output section of the AD-S8fx here.
- * Each output has a similar layout. Only ONE power input is needed, and a single power input provides power to all 8 x AD-S8fx outputs.
- * Layout of the 3-way connections is always "Left - Common - Right".

(More wiring diagrams are provided on the next page)

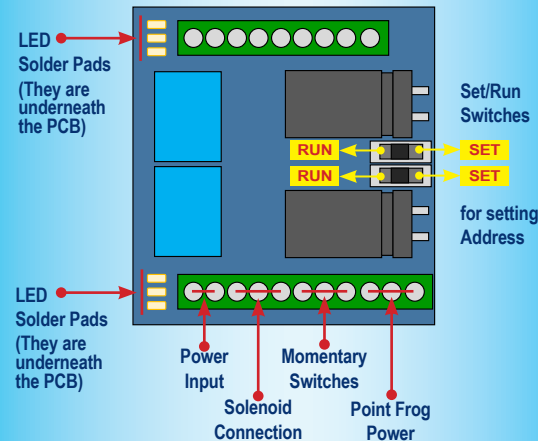

All connections are clearly printed onto the PCB

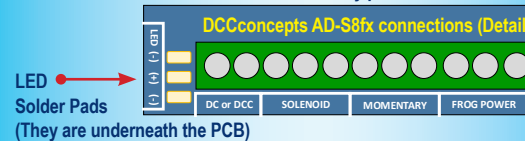

An 8-way AD-S8fx Solenoid Accessory decoder looks like this

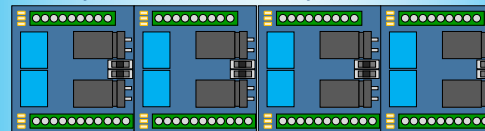

Cobalt AD-S8fx can do everything you need!

Overview: Cobalt AD-S8fx Connection

As you can see, each of the EIGHT ADS accessory decoder outputs provides you with everything you will need for perfect control and operation of any twin-coil solenoid point motor.

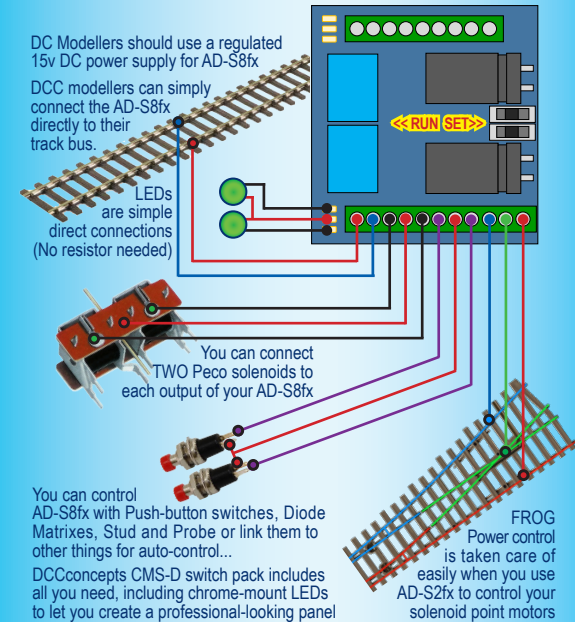

You can control AD-S8fx with Push-button switches, Diode Matrixes, Stud and Probe or link them to other things for auto-control...

DCCconcepts CMS-D switch pack includes all you need, including chrome-mount LEDs to let you create a professional-looking panel

Example: Cobalt AD-S8fx Connection

SOLENOID and FROG

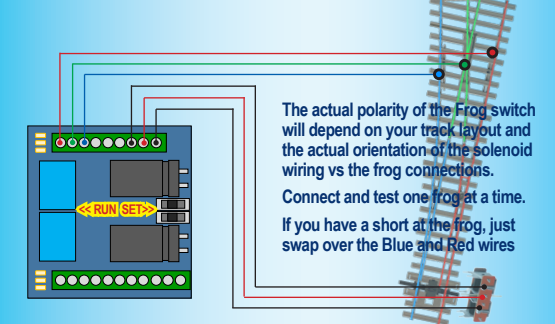

* Need help? please email us at:

Sales@dccconcepts.com

* Or visit our website at:

www.dccconcepts.com

* Or call us on +61 8 9437 2470 (10-5)



Example: Cobalt AD-S8fx Connection

POWER, LED and SWITCHES

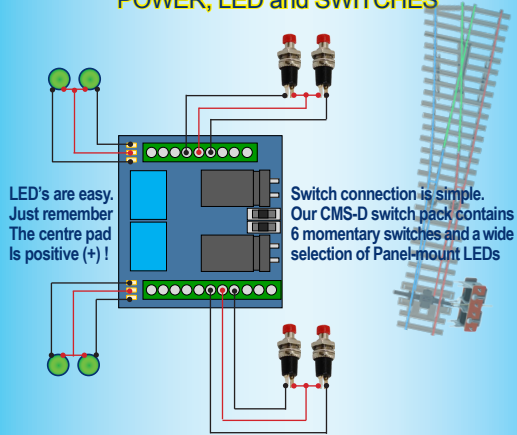

- Power Connections (only one power input powers all outputs)
- * DCC Modellers - connect AD-S8fx directly to the Power Bus
- * DC Modellers - please use a 15v DC regulated power supply

Important: AD-S8fx has a high power CDU on each of its outputs. Allowing the lower face of the PCB to contact conductive areas, metal tools etc. will cause serious damage to onboard electronics.

Setting the Address

Giving your DCCconcepts ADS decoder its own address is very easy.

Just remember to use ONLY these DCCconcepts instructions as all other DCC manufacturer instructions are valid only for their own accessory decoders.

You do NOT ever need to connect ADS decoders to a programming track

For ALL handset and console-based products that use a simple and direct "Press-the-button" routine to change a point/turnout, do as follows:

* Connect the AD-S8fx to the track power bus or the dcc accessory power bus.

* Decide on the number that you wish to give each AD-S8fx Decoder output

* Carefully move the "Set/Run" switch of that output to the "SET" position

* Follow your control systems instructions for Operating a point at that address. Use just the number only - do not add any leading zeros. (3 = 3, not 0003)

(Complete the operation totally - from "select address" to "changing the point").

* Return the "Set/Run" switch to the Run position and your ADS decoder will now respond to that address - it really IS that simple!

For ALL Screen-based products such as ESU, Z21, Hornby E-link and similar products you may first have to set up a track diagram or add a new point (turnout) to the controller system's accessory control library. Next, using your controller instructions, first complete the on-screen track plan or enter any information needed for the new accessory. Once that is done, and you have chosen which turnout on your on-screen display you want to control, all you need do is follow the instructions above.

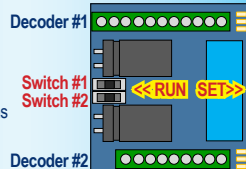

The Cobalt Collection - Point Motors & Signal Levers

While the first Cobalt product was a unique form of point motor, the DCCconcepts "Cobalt Collection" has already evolved to be much, much more than that.

Our Cobalt range now includes a wide range of Point Motors, Signal Levers and extremely high-feature level Accessory Decoders... accompanied by an economical and versatile range of Accessories. Cobalt continues to evolve and now includes many other products, each unique in its class. Before too long, the Cobalt Collection will include everything you will ever need to control the layout.

Cobalt Ω (omega) Point Motor

Successor to the original Cobalt, Cobalt Ω looks very familiar but it has been totally re-tooled inside and out to make them even better. Cobalt may look the same as before... but Cobalt Ω has a revised internal gear structure, is even quieter than its predecessor and now features THREE on-board SPDT switches for extreme versatility.

We have also added a simple to use voltage range-change switch giving you totally reliable performance over a very wide power supply choice (We like to operate at 9v, but really anywhere from 6 ~18 volts DC is just fine).

Current users of Cobalt motors will find the Cobalt Ω operates in total harmony with their existing Cobalt motors. The only significant wiring change being the position of the connections. These are now moved to terminals 1 and 2 (same as Cobalt iP and iP Digital) to keep all "New Generation" Cobalt motors in harmony.



Cobalt iP Analog Point Motor

While the shape is familiar, our Cobalt iP Analog has the same super-quiet operation and 3 on-board switches of Cobalt Ω plus a simple to use "Swap direction" switch to let you synchronise the changing of direction with software / macros or route control.

We have also added something very special inside.... The iP in the Cobalt iP Analog name means Intelligent power control! Cobalt iP Analog self-manages power use for the same drive speed irrespective of voltage (7~23v is OK).

When it's standing still, Cobalt iP Analog draws only enough power to listen for the next command and even when operating, it draws only 40~60mA. That is in fact less than the current draw of one super bright LED! Cobalt iP Analog really is the best choice for larger, busy layouts!



Cobalt iP Digital Point Motor

Cobalt iP Digital includes all of the features of iP Analog and more! Connection-wise, we've added a second set of momentary push button switch contacts for fully independent left/right "change direction" control (instead of 1-button toggled action).

Cobalt iP Digital is comfortable with 7~23v DCC track power and is super-easy to install as it's delivered self-centred and ready to go!

Cobalt iP Digital also has three simple-to-use software commands built in. We've made use of these easy by utilising standard "Address-setting procedures" to activate or deactivate them. These new software options activate or deactivate the self centering function and also let you "flip the change direction".

This allows you to synchronise or change operating direction so that it matches perfectly with track diagrams on screen-based control systems & with any brand of layout control software, route control or similar digital control methods.

(It also makes it possible to install Cobalt iP digital facing either the Toe or Heel of the point, so installations in tight places are easier!)

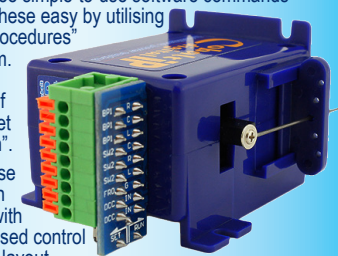

Cobalt-S Traditional Signal Levers

Cobalt-S is something very special. For the first time, the average modeller in ANY scale can have a signal-box lever that operates just like the real thing. Even better, the Cobalt-S lever really is the most versatile control device ever offered by anyone, as it can literally control everything ever made... by any brand - in any scale.

Cobalt-S includes both a momentary contact SPDT changeover switch and TWO on-on SPDT changeover switches, giving it the ability to work with AC, DC or DCC control and literally capable of operating every item ever designed for use with a model railway.

At 140mm high, it is a substantial product that is very satisfying to use... the lever and mechanism itself is solid brass, the contacts are high quality long-life phosphor bronze and the case is a tough engineering plastic.

Cobalt-S oozes quality and as a result it is guaranteed for life! The full Cobalt-S range can be seen at www.dccconcepts.com...

Please drop in and take a look soon!



Cobalt Accessories

Each & every Cobalt product has a matching range of accessories.

These are of course perfect for Cobalt product operation and they represent exceptional value as we always include many options in the pack.

We pre-wire some switches to make installation easier too.

The full range of accessory packs is shown and explained clearly on our website at

www.dccconcepts.com...

Please visit us there soon!

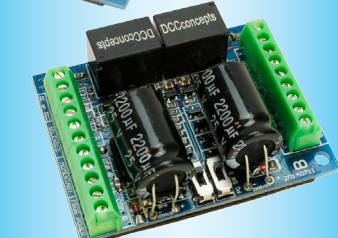
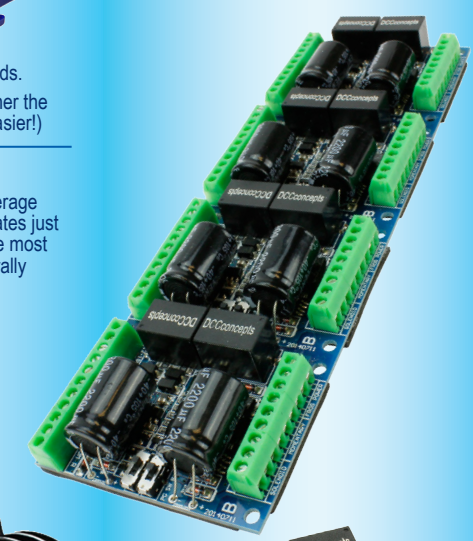

AD-S8fx is easy to set up & easy to address!

To add icing to the cake, ALL three new Cobalt point motors now come pre-centred and ready to install. (Cobalt iP Digital also has a unique set of software commands to activate self-centering). We now also include our die-cut "foam mounting pads" free with every Cobalt point motor.

DCCconcepts
Thinking Outside the Square!