

Cobalt digital

Introducing Cobalt Digital - the best turnout motor available... Quick & simple to install, incredibly easy to wire, super reliable & very, very simple to program & set-up for DC, DCC or manual control.

Cobalt digital is quick to install

Cobalt needs only a simple hole through the baseboard & can be secured by the screws we provide or even just double sided tape if you've paint-sealed the baseboard.

Alignment is as easy as it gets and easy to use built in adjustment allows huge flexibility in baseboard thickness.

Cobalt can also be mounted sideways for efficient operation of semaphore signals & crossing gates if you prefer!

Cobalt digital is easy to wire

Cobalt digital needs just two wires connected to operate with DCC - and just two more plus a standard pushbutton switch add the choice of DCC or manual operation.

(substitute DCC power for a 12v regulated DC power supply and those same 4 wires will have it working on a non-digital DC or AC powered layout too!).

For your DCC layout, add ONE more wire and you have frog polarity control... Adding Panel lights is easy in either DC or DCC mode thanks to built-in switching, and with all of this taken care of there is STILL a full S.P.D.T. switch free for control of isolated sections to protect approach tracks or your choice of signal or other devices.

Cobalt digital is simple to set-up

Cobalt digital has an easy to see and easy to use switch right on the connector PCB that will let you set or reset DCC accessory addresses in moments - Just acting as if you are controlling it sends the program information so you NEVER have to use complicated CV programming sequences or a special programme track.

DC modellers need no setup at all - all you need do it connect a 12 regulated power supply and add a simple pushbutton switch for total control with zero effort.

Cobalt digital is incredibly versatile

Cobalt Digital works extremely well and is both gentle and



powerful enough to give super reliable results with any gauge or scale from super tiny T scale, through (continued) to Z and N, and on to TT, OO and HO, S, O and Gauge 1. Cobalt digital can be equally well controlled by DCC, DC or a simple pushbutton toggle switch.

Low current draw and simple wiring is just the start... Your layout wiring and potential for turnout related control is made very versatile by the addition of two onboard switches that will allow you to do it all... panel lights, frog power control and signal interlocking: Cobalt digital has it already built-in and nothing more is needed, ever.

Cobalt digital is extremely reliable

Cobalt Digital has been made using top quality materials and is tested at every step of its manufacturing process... then tested once more before we ship them to you!

We are so confident that we offer a comprehensive lifetime warranty for all mechanical, switching and motor drive parts and an extended warranty for digital components. We think warranties should be honoured properly too, so we guarantee to hold plenty of spare parts in stock at all times to back our warranty service.

Cobalt digital

Cobalt digitals 'simple sophistication'

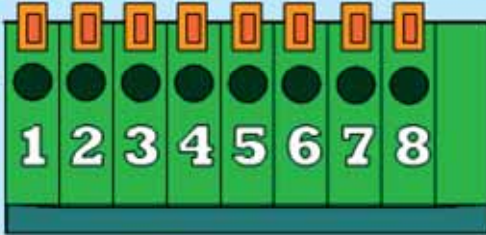

View looking directly at the solder-free connector.
Cobalt digital draws almost no power so light wire is just fine!



View looking at the underside of the PCB
(the switch is easily moved with a pen tip etc - Do not use too much force please!)

As you can see from the image, Cobalt digital is easy to wire.

- At its simplest, all you need to do is to connect terminals 1 and 2 to DCC track power and you are done.
- Add one more wire to terminal 3 (F terminal) and you have full frog polarity control. (See page
- Add 2 wires to terminals 4 and 5 (PB terminals) and connect to a simple low cost "normally off" momentary pushbutton switch & you have both DCC and panel control.
- Use terminals 6, 7 and 8 (marked Common, Left and Right) to control signals, to control power to isolate rail sections to prevent over-run when the point is set against an oncoming train or in fact, to control whatever you like - its all built in ready for you do anything you ever dreamed of!

EXPERT WIRING TIP:

When stripping wires for wiring Cobalt Digital, don't just pull the insulation off! Make it easy first time by doing it the way real professionals do & never have stray strands!

- Use light wire - about the same weight as "droppers" (for example 7x.2mm or 16x .2mm is more than enough)
- strip about 10mm of insulation. Use strippers or a knife to ring-cut insulation then twist the free end between your fingers as you pull it off - Try it now to see how neat it is.
- Depress the orange tab & insert the wire all the way in.
- This gives a super tight twist to the strands and totally guarantees that there will be NO loose strands!

Cobalt Manual Contents

- 1 Introduction to Cobalt Digital
- 2 Basic instructions, Specification, Connection
- 3 Installation guidelines
- 4, 5, 6 Wiring for DCC control and its options
- 7 Wiring for 12v DC control and its options
- 8 Common control of Loops and crossovers
- 9 Wire a turnout for best running & reliability
- 10 *The unique Cobalt Digital Warranty*

Cobalt facts & specifications

	28.5mm (34mm over mount wings)	44mm (67 mm over connector)	40mm (48mm over mount wings)
W x H x D			
Approvals	Cobalt meets all European CE standards		
Using DCC @ 14.5v	22mA when static. 18mA when changing. Controllable via DCC or momentary push button switch. Do NOT exceed 16.5v DCC		
Using DC @ 12.0v	A 12v regulated DC p/supply needed. 20mA when static. 16mA when changing.		
Easy wiring	Totally solder-free. Fine wire OK. Strip wires 10~12mm and twist tightly. Hold back tab & insert fully before releasing.		
Versatile control	Can be controlled Digitally, via conventional DC power & with panel switches		
Mounting ability	Vertical for turnout operation, horizontal for semaphore signal or vertical lift crossing gates etc. All screws provided.		
Noise level	Quietest of all motor drive turnout control devices at recommended voltages		
Control type	High gear ratio guarantees that it will not "relax" at the end of throw. Wide adjustment and positive, gentle action.		



Cobalt digital

Adding an address to Cobalt digital

Teaching Cobalt digital its address is incredibly easy to do.



Cobalt Digital
Never, Ever
needs you to access
CV's or use any
form of complex
programming or
any program track.

- (1) Install and wire your Cobalt Digital ready to use. If you prefer to set the address before installation just connect terminals 1 and 2 to your DCC track or Power bus.
- (2) Using the tip of a pen or similar, carefully move the PCB mounted switch (as above) over to the **SET** position.
- (3) Follow your controllers standard method for operating an accessory decoder, using the address you wish Cobalt digital to remember. (some examples shown below)
- (4) Using the tip of a pen or similar, move the PCB mounted switch carefully all the way back to the **RUN** position.

Your Cobalt digital will now remember the number you used in step 3 as its address and respond each time you use it.

Examples of typical actions by brand.

NCE POWERCAB & POWER PRO, GM/MRC PRODIGY

Put Cobalt digital into "set" or learning mode with the switch.

Press the "Accessory" key. Now enter the number you want to allocate to that turnout / that Cobalt digital and press enter followed by either the 1 or 2 key. The Digital Cobalt will "acknowledge" by moving slightly.

Now, carefully return the Cobalt digital set/learn switch to the "run" position and test that it operates on the number entered.

(NCE Information from Page 33 of the NCE PowerCab manual)

ESU ECOS *(Please disable rail-com to ensure reliable communication)*

Put Cobalt digital into learning mode with the switch.

Enter a new accessory as per ECOS 50200 manual page 23/24. (starting at part 13). When entering it use the number you want it to respond to (treat the setup procedure it as if it was already addressed)

Leave timing at the default of 0.25 seconds and set it up as momentary operation.

Once it is set up in ECOS refer to page 24 part 13 and act as if operating your Cobalt digital.

HORNBY ELITE *(disable railcom to ensure communication)*

Put Cobalt digital into learning mode with the switch.

(Refer to p38 of the Hornby Elite manual for more details)

Press ACC. And the screen will show the last accessory or turnout number used. Press ACC again if an alternative number is required.

Rotate either Control 1 or 2 until the number that you wish to teach to the Cobalt digital is shown, then Press the appropriate Control knob to confirm.

Return the Cobalt digital switch to the "run" position.

LENZ SET 100 *(disable railcom to ensure communication)*

Put Cobalt digital into "set" or learning mode with the switch.

Press the F Key then Press 5 to access the turnout control menu. Now enter your chosen number for the Cobalt digital that you have set to "learn" mode. Once you have entered the number, press enter followed by either the + or - key.

Return the Cobalt digital switch to the "run" position.

(Lenz accessory information from P21 of V3.6 LH100 manual)

DIGITRAX ZEPHYR

Put Cobalt digital into "set" or learning mode with the switch.

Press the **SWITCH** Key then use the numeric keypad to enter the turnout address that you want Cobalt digital to remember. Follow this by pressing the c/- key or the t/- key

Return the Cobalt digital switch to the "run" position.

IF IN DOUBT REFER TO YOUR OWN SYSTEM MANUALS

Reversing direction of commands:

Sometimes you'll want Cobalt Digital reverse its action in relation to "closed or thrown". To do this simply turn Cobalt Digital 180 degrees. Where this is not possible because of baseboard construction we recommend that you use the Standard Cobalt & AD1 Accessory Decoder.

Railcom users please note:

Railcom's communication methods can sometimes interfere with communication between accessory decoders or Cobalt Digital & the command station making addressing of accessory decoders difficult. We therefore strongly recommend that Railcom is disabled while you are teaching Cobalt Digital or an AD accessory decoder its address.

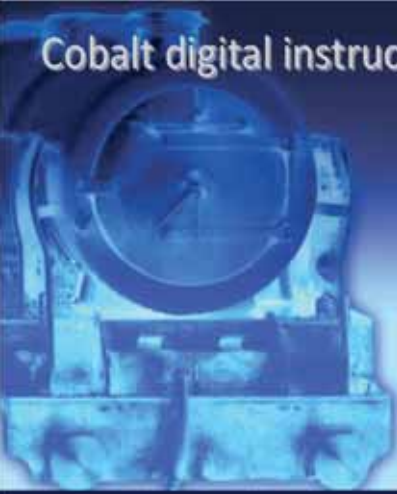

Cobalt digital

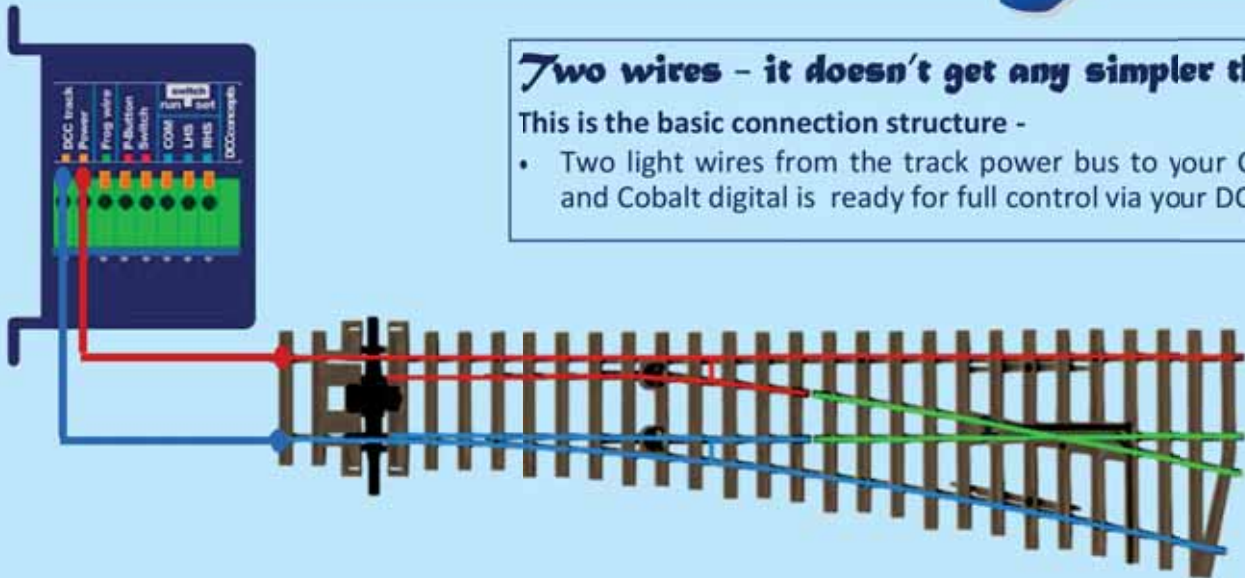

Two wires - it doesn't get any simpler than this!

This is the basic connection structure -

- Two light wires from the track power bus to your Cobalt digital and Cobalt digital is ready for full control via your DCC system!

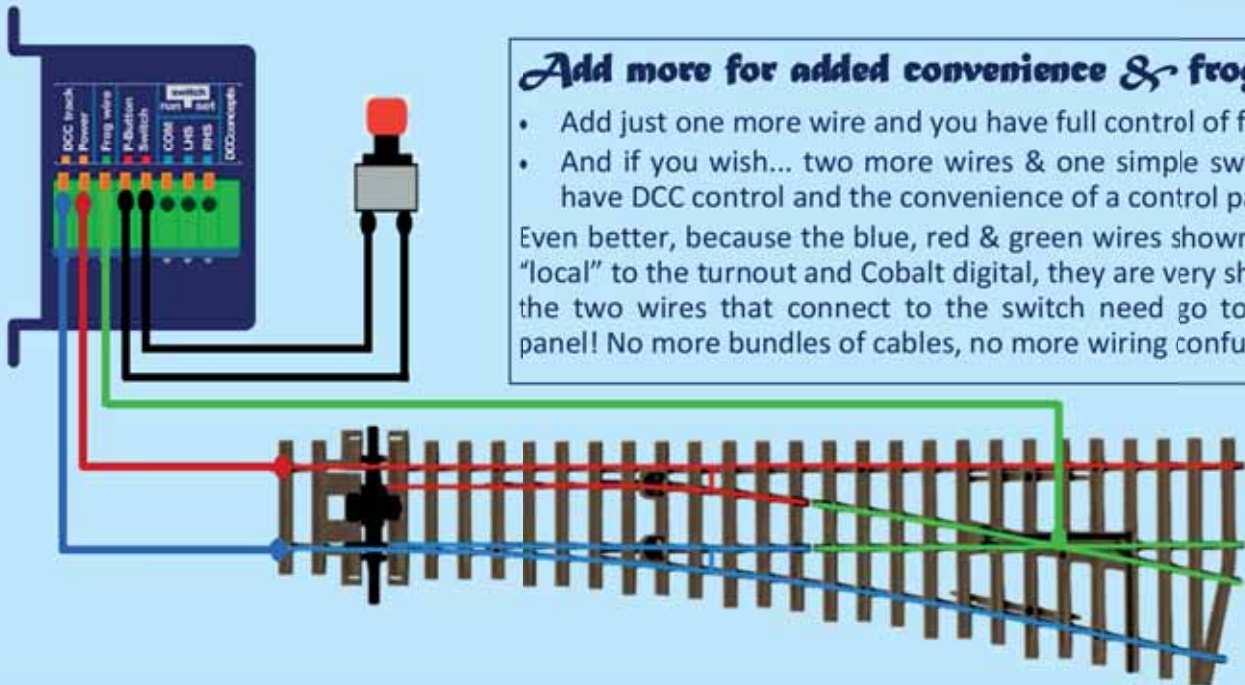

Add more for added convenience & frog power!

- Add just one more wire and you have full control of frog polarity.
- And if you wish... two more wires & one simple switch and you have DCC control and the convenience of a control panel as well!

Even better, because the blue, red & green wires shown here are all "local" to the turnout and Cobalt digital, they are very short and only the two wires that connect to the switch need go to the control panel! No more bundles of cables, no more wiring confusion at all!

Cobalt digital's 'Pushbutton control' ability: its the baseline for very easy automation too!

Its very simple... Press it once and the turnout changes, press again and it will change back. You can connect one switch to both motors on a loop or crossover too. Its much more than that though... Add a detector or instead of a pushbutton switch & it can change the turnout as a train approaches, preventing accidents. Use your imagination!



the best of everything Cobalt and Cobalt digital are designed and created by DCCconcepts. The Cobalt range is distributed in the UK by Gaugemaster Controls

Cobalt digital

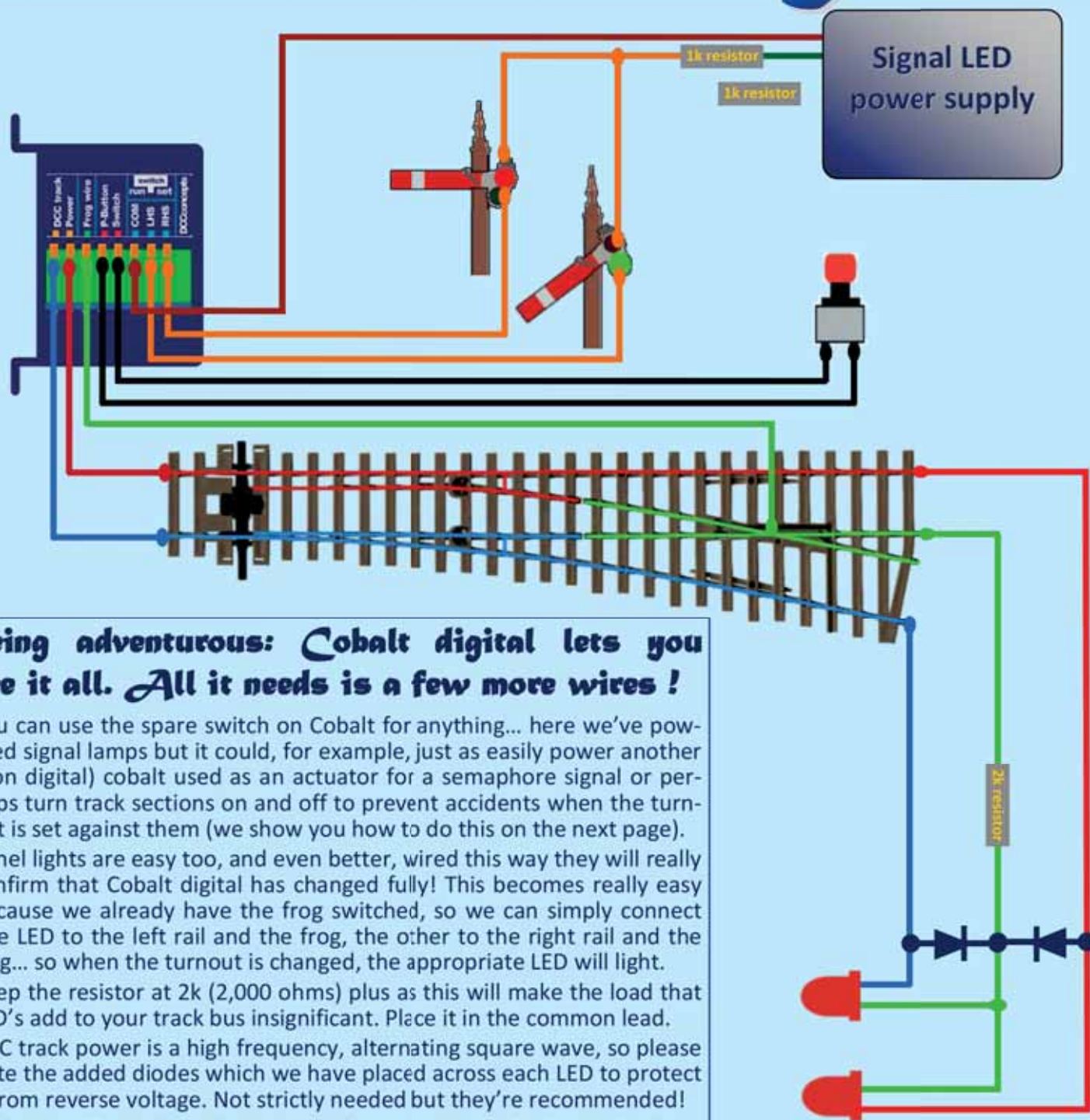

Being adventurous: Cobalt digital lets you have it all. All it needs is a few more wires!

- You can use the spare switch on Cobalt for anything... here we've powered signal lamps but it could, for example, just as easily power another (non digital) cobalt used as an actuator for a semaphore signal or perhaps turn track sections on and off to prevent accidents when the turnout is set against them (we show you how to do this on the next page).
- Panel lights are easy too, and even better, wired this way they will really confirm that Cobalt digital has changed fully! This becomes really easy because we already have the frog switched, so we can simply connect one LED to the left rail and the frog, the other to the right rail and the frog... so when the turnout is changed, the appropriate LED will light.
- Keep the resistor at 2k (2,000 ohms) plus as this will make the load that LED's add to your track bus insignificant. Place it in the common lead.
- DCC track power is a high frequency, alternating square wave, so please note the added diodes which we have placed across each LED to protect it from reverse voltage. Not strictly needed but they're recommended!
- With the LEDs and pushbutton switch, we now have 5 wires going back to the control panel. Use 6 core alarm wire & it will stay neat & tidy.

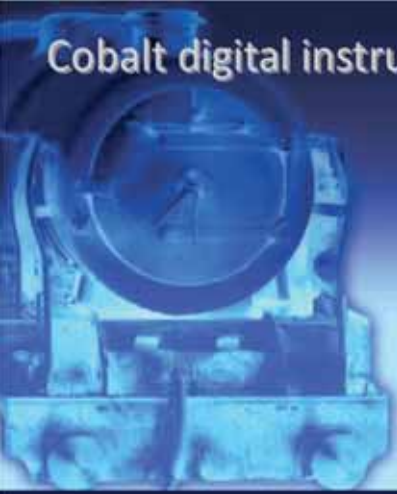

Cobalt digital

Safety interlocking to prevent access to a wrongly set point!
 As with the previous page, we have frog switching & button control, but we now connect the frog to the common terminal of the spare built-in switch, using it to turn off power to whichever of the PURPLE isolated sections has the point set against it

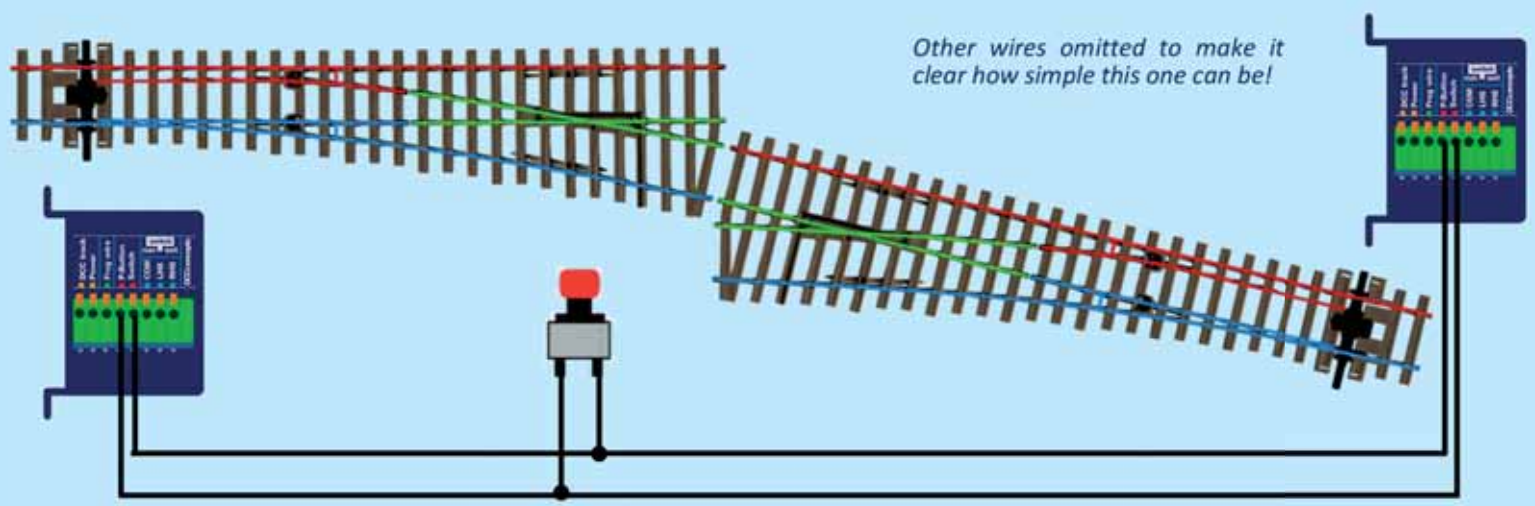
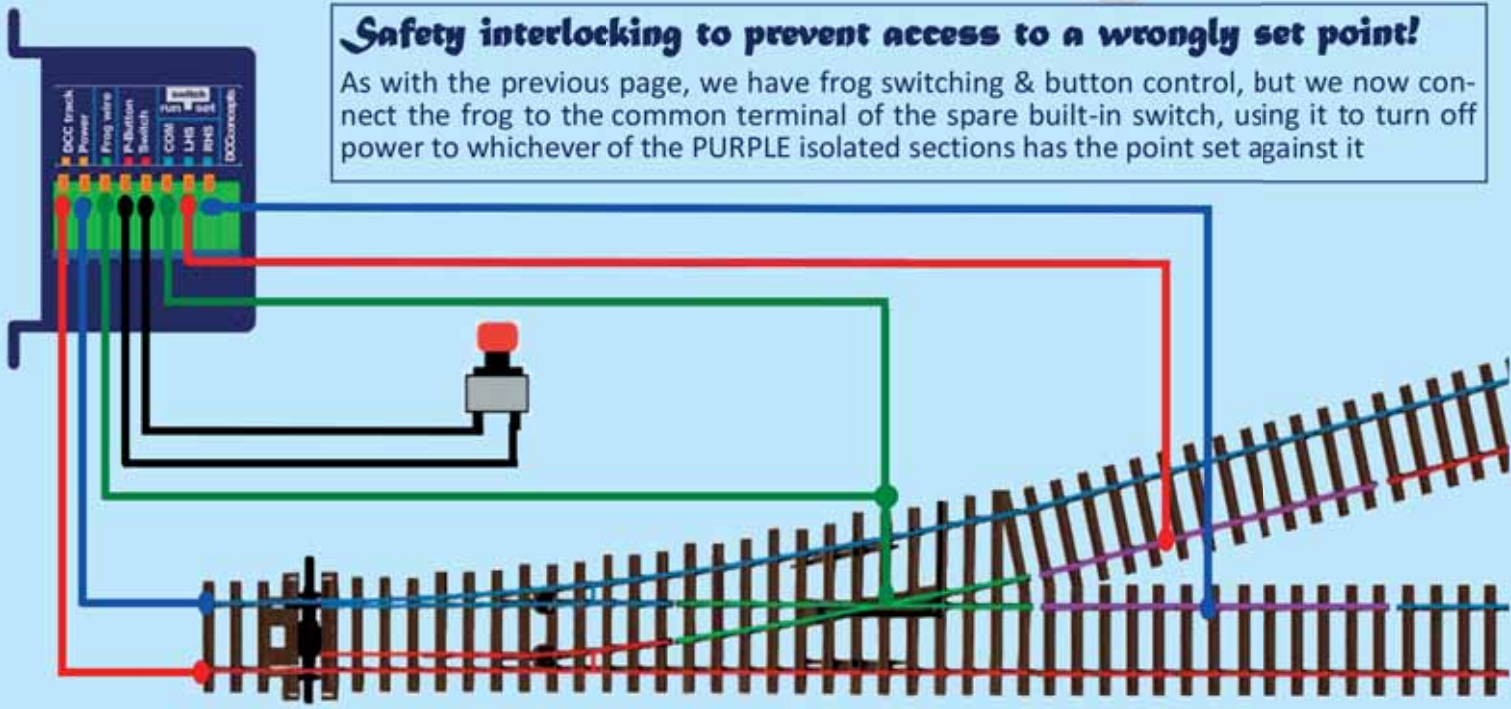

Yes - two or more Cobalt digital can comfortably share one pushbutton switch!
 For either loop control or control of crossovers (or a full scissors crossing if you like) you can use a single accessory address and a single pushbutton switch, making control... and your control panel, simple to operate with. (& you'll have LOTS of spare switch positions to control signals, interlocking or related diamond crossing frogs!)

Cobalt digital

Cobalt digital makes your DC powered layout wiring much easier than you ever thought was possible!

- Connect Cobalt digital to a 12volt DC regulated power supply. As it only draws any power when changing, a small wall type power supply is ideal.
- Add 2 more wires & 1 simple switch and you have full control. Only 1 button is needed as it "toggles", changing each time it is pushed.
- The power supply for Cobalt digital and the track are of course different when powering it with DC so you will need to use the "spare switch" for frog power. (The left hand drawing below covers this).
- Providing that a totally separated power supply is used and no other part of the circuit is "in common" with track power, you can use the SAME switch (as shown below, for frog power under DC control) to switch panel or signal lighting too... Just double up on the wiring!
- You can't use the "frog" terminal to switch the frog on a DC layout but you CAN still use the frog terminal for panel lights or signals. Its simple! The right hand drawing below covers this. In this drawing, blue is (-)

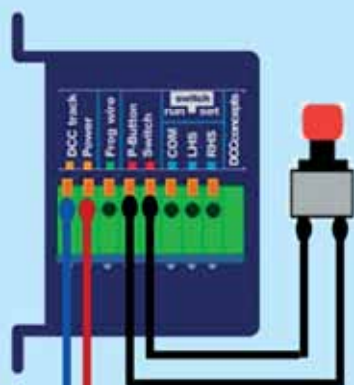

12v DC Regulated power supply
(Any 1 amp 12v DC wall plug supply is OK)

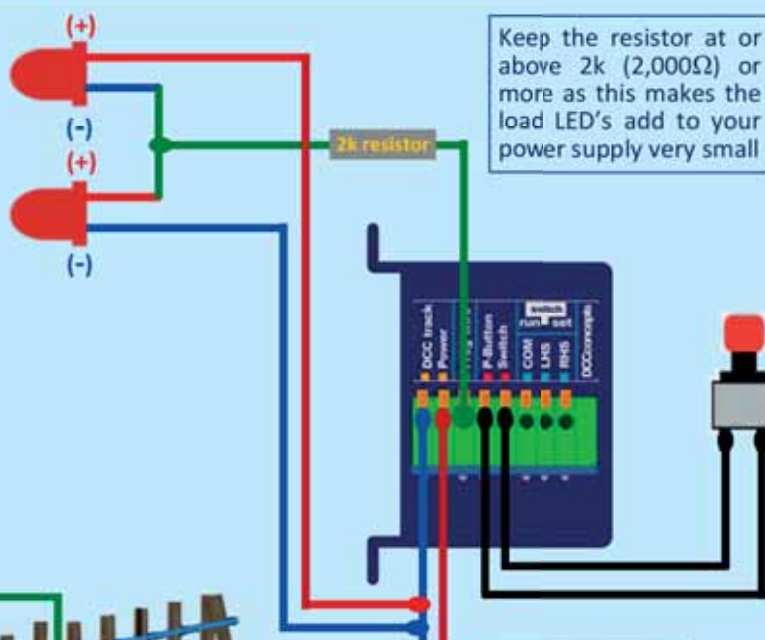
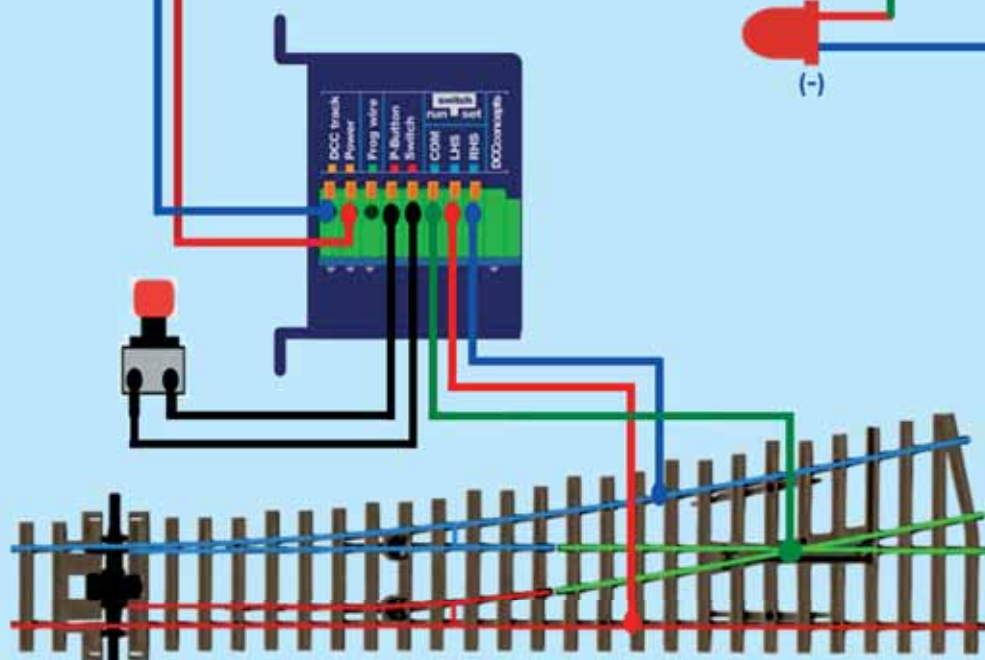

Keep the resistor at or above 2k (2,000Ω) or more as this makes the load LED's add to your power supply very small

12v DC Regulated power supply
(Any 1 amp 12v DC wall plug supply is OK)

Cobalt digital

The DCCconcepts Cobalt Accessory pack range has been created to cover all possible needs.. Items to make installation easy to get right first time, Handy Ballast label stickers, Custom shaped Foam pads and even parts you may need to manage future re-installation

Accessory, installation and Accessory packs

The TEMPLATE Pack: DCP-TMB

Includes the all-metal Cobalt template suitable for use with all popular gauges from (N to gauge 1) & we also include the drill you will need to make the pilot holes for easy mounting and the drilling of the tie bar for the actuator wire!

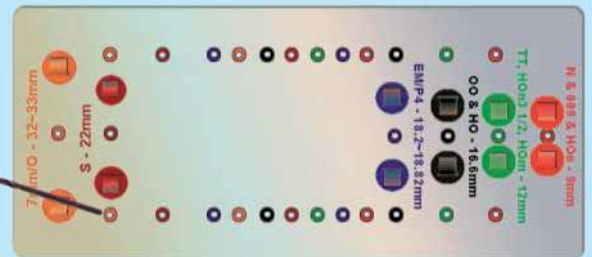

The ADDED VALUE Pack: DCP-CMC

This is a really useful pack that is excellent value. It is packed full of items that help to make installations easier

- 12x pre-printed "ballast look" labels to cover the actuator hole
- 6x double sided foam pads for Cobalt mounting
- 1x 7mm HSS drill bit for drilling the actuator wire hole
- 1x 0.8mm HSS drill bit for drilling pilot holes
- 3x spare actuator wires for Cobalt turnout motor
- 3x spare washer head screws for Cobalt turnout motor
- 12x 12mm #4 screws for Cobalt turnout motor mounting

The "Ballast Label" & foam pad pack: DCP-CMFP

Easier and quieter installation—and no more ugly baseboard holes to be covered before ballasting!

This excellent value low cost pack includes a dozen each of our very tough pre-printed "older ballast look" Mylar coated stickers & our pre-cut double sided self adhesive foam pads for a very easy and super-silent Installation of Cobalt.

The Ballast stickers: Made of durable Mylar, they are printed with scale sized "weathered ballast" and self adhesive, However they cleverly have glue ONLY where its needed, leaving the tie bar area clear for free movement.

The Foam pads: Super sticky, these pads fit the top of Cobalt perfectly and make physical installation incredibly easy.

The glue is very stable and strong and if you take the trouble to seal the baseboard where they will be placed you can remove the screws after 24 hours for an even quieter Cobalt Digital installation.

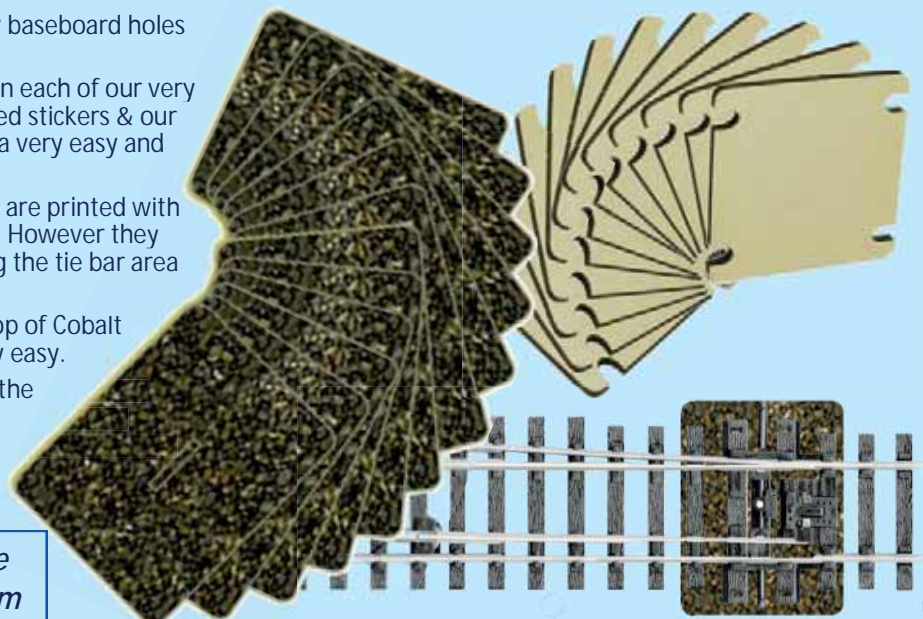

For even more Cobalt accessories, please see our website at www.dccconcepts.com

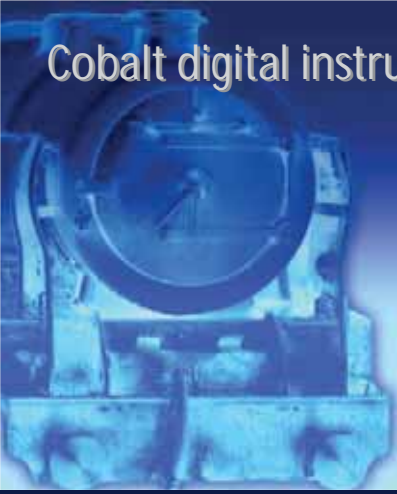

Cobalt digital

GET RID OF SNAP ACTION SPRINGS!

Cobalt has a smooth, positive action and there is no need whatsoever for any over-centre springs or snap action type devices in the turnouts that it powers.

Besides - why would you want them to "snap" over, when the steady movement of Cobalt is more reliable and prototypical!

So... for best results and greater realism...REMOVE the snap-springs from Peco or similar points and turnouts.

It really is easy - The inset pictures opposite show you how.

Turnout with a plastic pin.

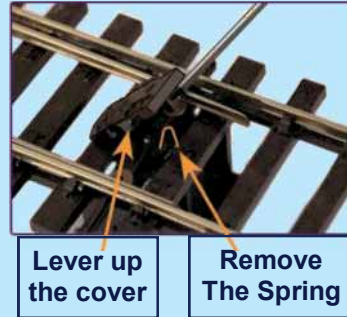

Turnout with metal tabs

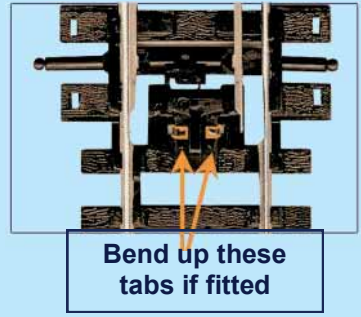

(1) Depending on the turnout, the spring cover will be held either by a friction-fit plastic pin or two metal tabs. Either prise up the cover (if you can see no metal tabs it will be held by a plastic pin) or bend up the metal tabs as shown above and raise the cover to see the fine phosphor bronze spring.

(2) Gently grasp the spring with tweezers or fine pliers & remove it completely... Now replace the spring cover and if it was held with metal tags, bend them back into closed position. Its that easy to do and takes only a moment.

USE ONLY LIVE FROG TURNOUTS.... And pre-prepare them for the best performance and reliability!

There is no greater frustration than building a layout using insulated frog turnouts "because it looked easier to wire them" and then finding that there are intermittent shorts at the frog, that point blades that use tabs to collect power stop working reliably as soon as they're ballasted & weathered... or that short locomotives stall on them when running slowly... as they will, as small loco's always run slowly in yards & sidings - and that's where the all of the turnouts are!

So... You really should use only Live frog turnouts. There's simply no doubt that live or "electro-frog" type turnouts are the best choice for reliability on any permanent layout & as they also usually cost no more - its just a sensible decision!

Even then we can make things better... And this has been made easier recently by Peco, as they now pre-prepare much of what needs doing, making it a ten minute job the make their electro frog turnouts about as good as they can be.

Its a simple process, as the diagrams below show. (Peco turnout used as an example)



Step 2 - attach the droppers

(1) attach a green wire to the frog. This should be wired to the common terminal of one of Cobalt's built in SPDT switches.

(2) Attach whatever colours you have chosen for your own track power to the blue and red rails. These wires go to the other two terminals on Cobalt SPDT switch.

Now, when you change the turnout, the polarity of the frog will change to match the route and you will have perfect running!

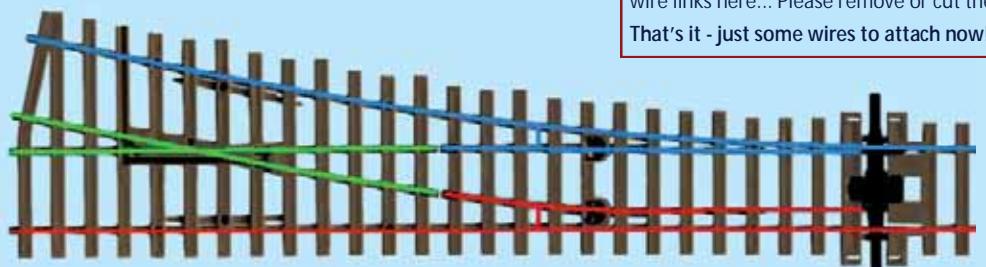

Step 1 - improve the power flow

(1) turn it over. You will see a wire attached to the frog area. Pull it from its slot ready to attach a dropper (it will be connected to the Frog wire terminal of Cobalt Digital under DCC control, or as per instructions on P7 of this manual on a DC powered layout)

(2) There are 2 orange bars on the drawing to the left. These are wire links you should add (solder them between stock and closure rails).

(3) There are two red lines. Older turnouts will need the rails cut here. Newer turnouts already have the rails gapped., but there will be wire links here... Please remove or cut them.

That's it - just some wires to attach now!

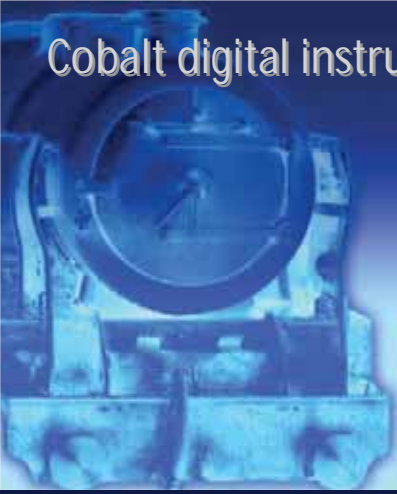

Cobalt digital

We have chosen the very best materials and taken great care with the design of our Cobalt turnout motor, using only the highest quality materials and incorporating such refinements as super low wear PCB switch contacts and a super strong and reliable drive system that can cope with a wide range of applications. The integrated accessory decoder conforms to all NMRA specifications and will work reliably with all known DCC systems and on DC when used with a properly regulated 12v power supply. Reliability is assured under all reasonable operating conditions .

The LIFETIME Warranty... Simple, fair and clearly stated in plain English.

(This Lifetime Warranty is not transferrable and applies only to original owners who purchase their Cobalt turnout motors from an authorised Cobalt stockist.)

Having designed Cobalt digital to last, we are pleased to offer you a lifetime warranty for its drive motor, the integrated decoder and all electro-mechanical parts when Cobalt digital is used and installed in accordance with the instructions on an indoor model railway in any scale. And powered by a standards compliant DCC system or properly regulated 12v DC power supply

The warranty applies when Cobalt digital is used in any reasonable application as an actuator for point/turnout control, signal control or any similar or related model railway purposes, providing that it is installed with respect and has not been subjected to water or corrosive liquids, has been properly wired in accordance with these instructions, operated within recommended supply voltages and power has been supplied to it by a properly rectified DC power supply or any NMRA compatible DCC decoder with a voltage and power output which meets our specifications.

Caution: Cobalt digital is tough however there are some parts that need respect such as the connector and programming switch. Physical damage of any type is not covered by this warranty. We do therefore ask that you use an appropriate device such as a pen tip, toothpick or small screwdriver when using the connector or moving the built-in programming switch as excess force can damage these parts.

The first year after purchase....

If your Cobalt turnout motor or any part of it fails under any fair and reasonable operating conditions within 12 months of purchase please return it either to us or your retailer along with a copy of your purchase receipt.

If returning by mail or (enquiring by E-mail) include a description of the installation and how it failed.

Providing that examination proves that the failure was not due to physical abuse, water or similar damage, over-voltage or excessive current loading on switch contacts, your retailer is authorised to make this decision locally without further reference to DCCconcepts and so once warranty cover is agreed you will promptly receive a new Cobalt turnout motor from your retailer free of charge.

In case of uncertainty: *If your retailer is unsure of any issue relating to the failure he may choose to refer the claim to us at DCCconcepts Pty Ltd along with your contact information and in that case we will promptly assess the failure and if warranted, supply your replacement directly from our offices.*

For the rest of the time you continue to own Cobalt....

If your Cobalt turnout motor or any part of your Cobalt turnout motor fails under what are reasonable operating conditions at any time after the initial 12 months following purchase, please contact DCCconcepts Pty Ltd directly, advising of us how Cobalt or any of its components has failed.

Once the required description of the failure and other information has been received (including proof of purchase) we will then decide whether to ask you to return it for evaluation, repair or replacement, or... if it is a simple issue and if it will save you post cost and time, with your prior agreement we may simply offer to supply you with the parts needed to carry out the repair yourself.



Cobalt and Cobalt digital are designed and created by DCCconcepts. The Cobalt range is distributed in the UK by Gaugemaster Controls