



***This manual applies to DCCconcepts ZEN, ZEN BLUE+ and ZEN BLACK Series decoders.  
(Some features are however only available in decoders from ZEN software version 12)***

**We have often been asked for a more detailed decoder manual, so here it is!**

### **Please note:**

*The exciting features available from Zen Blue+ and Zen Black decoders were the main motivation for the creation of this very detailed manual, but if you have our original DCCconcepts ZEN decoders, this manual is for you too! That is because as while there are definitely added things that only Zen Blue+ or Zen Black can do, many of the features, functions and CV settings you see here are also applicable to the original Zen decoder range.*

### **An introduction plus several highly detailed manuals:**

- Page 1~4: Introduction, specification, Zen decoder wiring and connections.
- Page 1~49: DCCconcepts ZEN BLUE+ and BLACK decoders - The FULL comprehensive manual.
- Page 1~ 15: Part 1: DCCconcepts ZEN BLUE+ and BLACK decoders - Motor control, Adjustment, Stay-Alive connections.
- Page 16~27: Part 2: DCCconcepts ZEN BLUE+ and BLACK decoders - Detailed lighting examples and Active Function setup.
- Page 28~48: Part 3: DCCconcepts BLACK decoders - DCCconcepts advanced ZEN ABC Braking, DCCconcepts advanced ZEN Stopping, ZEN's unique "Automatic Shuttle" control ability and ZEN simplified "Brake on DC".
- AND... Page 49: Addendum and NEW notes on decoder features, installation, use and set-up.

**All manuals are available online at [www.dccconcepts.com](http://www.dccconcepts.com)**

### **A few words from us... and our manual's "creator":**

- *Most things in here quite simple to do - and we have done our best to describe it all as simply as possible.*
- *CVs are covered in order AND also as part of each specialised area too, so you will always find what you need.*
- *Where setup is complex, we have included examples with every step covered so you can just copy them.*
- *Things like our unique approach to ABC automation are actually quite simple but there ARE some quite complex applications and diagrams in that area too . Blame me for that - sorry! It is NOT because you have to do it that way - it is just because we are excited at just how much our advanced ABC approach can achieve... and I really, really wanted to show you what it could do for you with very little extra effort!*
- *I also want to encourage you to "Have a go" at some of the things we have discussed here, because there is so much more than most modellers ever see, hidden inside every Zen decoder that we create.*
- *From all of us: We hope you enjoy it - thank you for sharing your hobby time with us.*



**Zen Decoders are imagined, designed and manufactured by DCCconcepts Ltd  
Our showroom and offices are located in Settle, North Yorkshire BD24 9RP, England  
Phone: +44 (0) 1729 821 080 \* [sales@dccconcepts.com](mailto:sales@dccconcepts.com) \* [www.dccconcepts.com](http://www.dccconcepts.com)**



**Unique features, real performance and exceptional installability**

### **Introduction to ZEN and a little more about the things covered in this comprehensive manual:**

**Zen** decoder software has always been smooth, clever and easy to use but our new BLUE+ and BLACK decoder ranges take this to a new level, with extended and improved automatic braking abilities and simple-to-use ONE step locomotive set-up. Our Decoder design ideas do not just accept loco-space problems or installation difficulty... so they are designed to fit where others very probably will not. After all - great features and the best performance are of no value to you unless you can fit a decoder in a loco!

**Zen** decoders are assembled in an automated facility. Electronic parts have a "best before" date as critical things such as solderable surfaces need to be new for high reliability, so all parts deliveries are always "just in time".

The PCBs that we use are created within hours of assembly so that board surface preparation is still fresh and all surfaces are 100% free of defects and contamination at the time of assembly.

Actual assembly is then carried out by fully automated machinery with superb accuracy.

Critical things such as machine-applied fluxes and solder baths are replaced well before recommended dates so that dry joints cannot happen and defect-free assembly and subsequent reliability can therefore be guaranteed.

Finally, once assembled, all of our decoders are tested at least 3 times before we package them for sale, so we know that they all work perfectly when we sell them and you can be quite confident that reliability is assured.

### **Stay-Alive: Zen BLUE+ and BLACK decoders :**

**Zen Blue+ and Black decoders have improved "Brown out" protection, so we no longer provide Stay-Alives in each pack. We have also made other changes to Zen stay alive support. You will find full details of this on page 15.**

- Zen decoders now have a plug-and-play 3-wire connector for the attachment of Stay-Alives.
- Rather than make Zen stay alives bulky and hard to install, they are now in two parts. A small plug-and-play control board and a selection of varying plug-and-play capacitor banks that you can select to fill your specific need for each locomotive.

### **Warranty Information:**

**Zen** decoders are made with great care, so we are able to have a simple & easy-to-live-with approach to Zen warranty.

- If any Zen decoder with no visible external damage fails to perform as it should, please return it. If we cannot revive it with a simple factory reset, then we will replace it for you free of charge.
- If a Zen decoder has heat damage, a burn mark on the heat-shrink or any other form of accidental physical damage, then we will replace it for you at 50% of the new decoders recommended retail price.

### **Decoder pack inclusions:**

Every **Zen** decoder is supplied complete and ready to install.

**Zen BLUE+ decoders:** Supplied complete with any required harness and a detailed manual.

**Zen BLACK decoders:** Supplied complete with any required harness and a detailed manual.

(Selected models may also be supplied with one DCD- ABC module for you to experiment with)

### **Additional ABC parts and Accessories:**

We are confident that **Zen BLACK** owners will want to exploit the advantages of our ABC automated stopping system so we have also added some new accessory packs that include these very simple braking control boards.

**DCD-ABC.3** - A pack of three ABC Automatic Brake Section control boards.

**DCD-ABC.6** - A pack of six ABC Automatic Brake Section control boards.

**DCD-BDC.3** - A pack of three BDC Automatic "DCCconcepts Simplified Brake on DC" section control boards.

**DCD-BDC.6** - A pack of six BDC Automatic "DCCconcepts Simplified Brake on DC" section control boards.

**DCD-HDR.6** - A pack containing 6 spare headers, 3x Red, 3x Blue.

**Please look at page 15 and our website for details of Stay-Alive, harnesses and other accessories.**



Zen Decoders are imagined, designed and manufactured by DCCconcepts Ltd  
Our showroom and offices are located in Settle, North Yorkshire BD24 9RP, England  
Phone: +44 (0) 1729 821 080 \* sales@dccconcepts.com \* www.dccconcepts.com



thinking outside the square  
concepts

**Unique features, real performance and exceptional installability**

**Part 1: DCCconcepts ZEN Blue, BLUE+ and BLACK decoders  
General Specifications, Motor control, Loco Running and Adjustments.**

Model	Peak	Continuous	Functions	Connector	Size (mm)	Actual decoder size
BLUE+ models have a BLUE background. BLACK models have a BLACK background.						(When page is printed at 100%)
<b>Z218.6 Black</b>	1.1 A	750mA *See notes	6fn x 100mA	21 and 8-pin	23 x 16.5	 (ABC) 6 Function
<b>Z218.4.2 Black</b>	1.1 A	750mA *See notes	4 x 100mA fn plus 2 x low power function	21 and 8-pin	23 x 16.5	 (ABC) 4 + 2 Function
<b>ZEN Mini Black</b>	1.1 A	750mA *See notes	4 x 100mA	8-pin wired	19 x 11	 (ABC)
<b>ZEN MIDI Black (New High Power)</b>	2.0 A	1.2A *See notes	6 x 100mA	8-pin wired	22 x 13	 (ABC) 6-function High Power
<b>ZEN N18 Blue+</b>	1.1 A	750mA *See notes	4 x 100mA	Next-18	15 x 10	
<b>ZN8D Blue+</b>	1.1 A	750mA *See notes	4 x 100mA	8-pin direct	16 x 8.5	
<b>ZN8H Back</b>	1.1 A	750mA *See notes	2 x 100mA	8-pin wired	16 x 9	 (ABC) 2-Function
<b>ZN6D Blue+</b>	1.1 A	750mA *See notes	2 x 100mA	6-pin direct	14 x 9	
<b>ZN68 Blue+</b>	1.1 A	750mA *See notes	2 x 100mA	6 and 8 pin	14 x 9	
<b>Z360.6 Black</b>	1.1 A	750mA *See notes	6 x 100mA (Six full power functions)	8-pin direct	16 x 14	 (ABC) 6-Function
<b>ZBHP Black (Buddha)</b>	5 A	3.5 A (Conservative)	6 x 250mA (Six full power functions)	12 terminals	42 x 27	 (ABC) 5 amp 6-Function

**POWER NOTES:** We have been very conservative in claimed power specifications. As a result, while we use parts that are identical in real-world power specification to those of our competitors, we claim only 750mA power handling where they may claim 1 amp or more. We do this because in reality, they are forgetting to tell you that while their decoder MAY take an amp, it will do so for only a second or two without potential problems! (In reality load any HO decoder to anywhere near an amp and you CAN expect excessive heating in just a second or so. All decoders are weakened or damaged by high heat levels and will definitely burn out if left with that sort of load.) Our more conservative rating will help you have a long life for each decoder. You need to consider this because the load on a decoder is not just the motor current. Every light/LED or other powered accessory has to share the available power, and when the train is long or under load, the current draw of a fully featured loco will often exceed expectations. Load generates heat, and constant load just stresses everything, so being a little conservative in the way you think about power handling will lead to greater long term reliability.



Zen Decoders are imagined, designed and manufactured by DCCconcepts Ltd  
Our showroom and offices are located in Settle, North Yorkshire BD24 9RP, England  
Phone: +44 (0) 1729 821 080 \* sales@dccconcepts.com \* www.dccconcepts.com

**Unique features, real performance and exceptional installability**

**Wiring and Connections for Zen Decoders.**

All Zen decoders follow the DCC standards exactly, using correct colour codes, connectors and pin diameters so we can be certain that, providing the loco manufacturer also does what they should, a plug-and-play connection will always work!

**TOP TIPS for reliable installations:**

- **Run the loco in on DC before installation:** Do this on the layout if you have a DC controller. If you do not have a DC powered test track, then we recommend use of a rolling road. <https://www.dccconcepts.com/product/rolling-road-multi-gauge-8-axe/>
- **Suppression capacitors:** While they can be left in if you are not confident, we always recommend removing capacitors from the locomotive if you can. They are often small biscuit-coloured discs that can be cut away without affecting other wiring. (They are part of the DC suppression circuit of the loco and are not required with DCC. If they are left in place they may, in some cases, affect the quality of communication between loco motor and decoder, preventing the best possible fine-tuning)
- **Clean the wheels and the areas where pickups make contact:** This also applies to new locos. You will be very surprised just how much black muck will come off them when you use a cotton bud and alcohol for the cleaning. Of course, also clean any track that will be involved with the decoders initial setup and running. Excellent wheel-to-track contact is needed for this.
- **Insulate any unused wires:** Your decoder may have more functions than needed and some wires may not need connection. It is, however, important to make sure that these wires are insulated at the end so that accidental contact is not made with the loco chassis or other "live" parts of the loco. Where space is tight, cut them shorter first. When we do this we leave 20mm (about 3/4") and then insulate. This should ideally be fine heat-shrink, however dipping the wire ends into some non-metallic nail polish and letting it dry is a low cost and easy-to-do option (dip or brush it on it twice to be sure its properly insulated).
- **Take your time and work in a well-lit, clean area:** Patience will reward you with good results.
- **If you are unsure, ask:** We are here 7 days a week and will always welcome questions. Contact details at bottom of page.

**ZEN STAY ALIVE INSTALLATION & WIRING**

Zen Stay-Alives are now modular - and "Plug-and-Play".

Making the Stay-Alive smaller is a challenge: however if we separate the power management from the storage, it becomes thinner, able to be placed in smaller places and will therefore be much easier for you to fit inside your locomotives.

There are several sizes of Stay-Alive available: See our website for details.

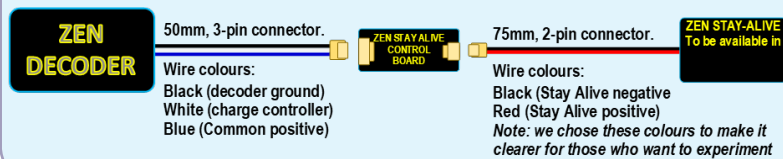

The very common 8-pin NEM 652 locomotive socket. (This is the view from the top of the loco socket)



The N scale 6-pin NEM 651 locomotive socket. (This is the view from the top of the loco socket)

This socket has no Blue + wire for lights! The lighting is always on half-wave power (grounded via the chassis).



**The HIGH POWER ZEN BUDDHA 6-function decoder.**

This decoder has interactive overload protection against overload or short circuits. Continuous load exceeds 3.5A, peak is 5A for loco drive. Use wire able to take these power levels. Created for large scale locomotives.

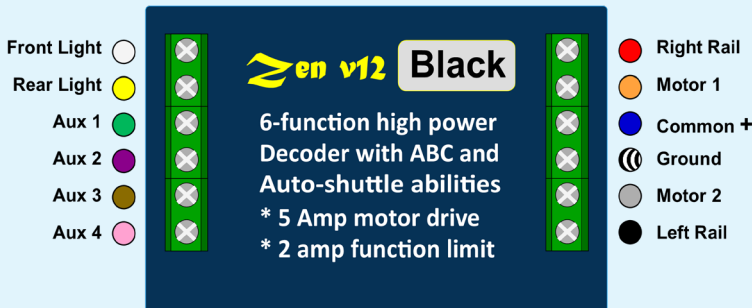

**21-pin MTC socket.**

(Again, this is what you see from the top of the loco socket)

Please note there are TWO versions of the Zen 21-pin decoder. One has 6 functions at full power, the other has Aux 1 and 2 at full power, but Aux 3 and 4 are at lower power levels. Your new loco could need either, so please check carefully!



There ARE other connectors such as Next 18 & PLUX, but they are generally plug-and-play only and not "user adjustable".



## Unique features, real performance and exceptional installability

**PART 1 - DCCconcepts ZEN BLUE+ & BLACK decoders - motor control, loco running and adjustment:** ZEN decoders comply with DCC standards & work perfectly with all properly designed DCC systems. This section explains general setup and motor-control.

ZEN decoder "motor control" gives you options well beyond normal loco operation as you are also able to configure the Zen motor drive circuit to power accessories such as turntables, cranes or other motor-driven devices. Motor speed can be fixed or variable and you can choose to operate via either conventional speed control, directly via forward/reverse controls OR via direct function-button control.

### NOTE PLEASE:

- If this is a NEW installation, please do the first steps on the Program track as this will be current limited and can often protect a decoder if there is something wrong with the loco, the installation or the decoder wiring. Then...
- If you are adjusting any movement or similar thing, then it will be better to do this on the main track, as you can make the changes and immediately see them (you can for example even adjust settings while the loco is moving!)
- Sometimes you will see 0 (Zero) as the default for a CV. This can mean either "Off" or "Maximum" depending on the CVs purpose.
- We suggest you use the 128 speed step setting when adjusting any motor control CV related to loco movement for best results.
- If you make an error, get lost or have results that are unexpected, you can re-set ZEN decoder to default by setting CV8 to 8.

<b>CV1</b>	Short address	Default = 3	Range = 1~127 (99)	<i>NO leading zeros please. i.e. #8 is simply 8)</i>
------------	---------------	-------------	--------------------	------------------------------------------------------

Use CV1 if you wish to set the SHORT address of the decoder. Usually this is between 1 and 127 (1 to 99 with Lenz). We do however recommend that you use the LONG address if possible, leaving this at the default of address #3. (Using the long address will let you use the actual locomotive number printed on its cab side, so you will not have to remember what it is!)

<b>CV2</b>	Starting Voltage	Default = may vary	Range = 1~255
------------	------------------	--------------------	---------------

Use CV1 to adjust the speed step at which your locomotive starts to move. If the loco moves off too fast at controller speed step 1, then reduce CV2 in steps if 1 until it crawls away on speed step 1. If the locomotive is reluctant to move off until the controller shows several speed steps, then increase it until it crawls away on speed step 1.

<b>CV3</b>	Acceleration	Default = 12	Range = 1~255
------------	--------------	--------------	---------------

Use CV3 to adjust the way that your locomotive moves off. This CV simulates load and mass so it will delay the loco start slightly and slow the acceleration vs. the control knob position, making the loco move more realistically. Settings well above our default of 12 may mean that your loco/train will take some distance to reach the speed you set, so experiment to find your ideal setting. We DO suggest that you always have some momentum, even if it is short, as this will smooth out the loco performance. (VERY important if you use 28 SS as this actually just makes the loco speed jump 4 speed steps at a time)

<b>CV4</b>	Deceleration	Default = 12	Range = 1~255
------------	--------------	--------------	---------------

Use CV4 to adjust the way that your locomotive slows and stops. This CV also simulates load and mass so it will make the loco slow down realistically by slowing the deceleration vs. the control knob position, making a loco move more realistically. Settings above our default of 12 will mean that your loco/train will take a longer distance to stop, so experiment to find your ideal setting. We DO suggest that you always have some deceleration set, even if it is short, as this will smooth out the loco performance. (VERY important if you use 28 SS as this actually just makes the loco speed jump 4 speed steps at a time)

<b>CV5</b>	V-Maximum	Default = 0	Range = 1~255
------------	-----------	-------------	---------------

Use CV5 to adjust the TOP speed of your locomotive downwards (it is already at maximum by default). Lowering this CV can make a loco more prototypical as, for example, a shunter (switcher) will have a lower top speed than other trains. As a guide, the chart related to CV25 will give you some ideas here. ALWAYS set CV 5 and CV6 (mid-speed) at the same time please, as both will contribute to the overall running performance. By the way - lowering CV5 and CV 6 will also compress the total speed range while leaving the same number of speed steps available, so it will refine loco control quite nicely.



Zen Decoders are imagined, designed and manufactured by DCCconcepts Ltd  
Our showroom and offices are located in Settle, North Yorkshire BD24 9RP, England  
Phone: +44 (0) 1729 821 080 \* sales@dccconcepts.com \* www.dccconcepts.com



**Unique features, real performance and exceptional installability**

<b>CV6</b>	V-Mid	Default = 0	Range = 1~255
------------	-------	-------------	---------------

Use CV6 to adjust the MID speed of your locomotive downwards (it is already at mid voltage by default). ALWAYS adjust CV6 if you change CV5. A linear acceleration will be maintained by setting CV6 and 50% of CV5 settings. However lowering this CV to LESS than 50% of CV5 settings can make a very pleasing difference to the way a locomotive accelerates from a stop. The best way to start to experiment is with CV6 = 33% of the CV5 setting and adjust up or down from there. CV6 should not exceed 66% or be less than 20% of the top speed, or results may be unpredictable. (If you get lost, then reset is CV8 = 8)

<b>CV7</b>	Manufacturer Version. <u>Not Adjustable</u> . Please see notes.
------------	-----------------------------------------------------------------

CV7 contains the software version information for the production batch in which the specific decoder was made. CV7 is only for manufacturer use so it is locked and not user changeable, but you can look at it if you wish. (Knowing this number may be useful if you are talking to us about your Zen decoder as it will help us to correctly advise you about some things.)

<b>CV8</b>	Manufacturer number <u>and</u> the Decoder Reset CV
------------	-----------------------------------------------------

CV8 contains the officially registered DCC manufacturer number for DCCconcepts. DCCconcepts ZEN will always be 36. CV8 is also the "Decoder Reset" CV - So: if you instruct your controller to change CV8 to 8 during either program track use or when using "Program on the main", the decoder will be totally re-set to its ex-factory default for all CVs, and the decoder address will become number 3 again. (After reset, CV8 will still show 36, as this is locked-in at all times)

<b>CV10</b>	BEMF cut-off step	Default = 0	1~128, but the recommended range is 1~80
-------------	-------------------	-------------	------------------------------------------

In this case the default of 0 equals ex-factory pre-set. We recommend you leave it at default unless you really need to adjust it. The value you enter into CV 10 directly correlates to the speed step at which the BEMF action will greatly reduce and/or cut out. For example, if you want to use BEMF to aid starting, but keep direct control (without automatic speed control on gradients for example) for the rest of the speed range, use CV10. To adjust when BEMF stops acting, simply enter any value into CV 10 that is between 1 and 128. The number you choose will then be the speed step at which BEMF stops acting on your locomotive.

<b>CV13</b>	Function outputs active on DC (this covers functions 1 to 8)	Default = 255 (0)	Set Range = Chart below
-------------	--------------------------------------------------------------	-------------------	-------------------------

CV13 lets you choose which lights, etc., will remain on when you are running your loco on a DC layout or under DC control. Please use the chart below. Select the functions that you wish to be ON when running with DC, then add up the numbers and enter that value into CV 13. For example, enter 7 into CV13 if you want Front and Rear lights plus F3 and F4 to be on with DC.

White wire (Front or head light) and Yellow wire (Rear light or tail light)	FL or RL	1
Green wire or Function 3	(Aux 1)	2
Purple wire or Function 4	(Aux 2)	4
Brown wire or Function 5	(Aux 3)	8
Pink wire or Function 6	(Aux 4)	16



<b>CV9</b>	<b>CV11</b>	<b>CV12</b>	<b>CV14</b>	These are not user-adjustable CVs. Please do not attempt to use them.
------------	-------------	-------------	-------------	-----------------------------------------------------------------------



Zen Decoders are imagined, designed and manufactured by DCCconcepts Ltd  
 Our showroom and offices are located in Settle, North Yorkshire BD24 9RP, England  
 Phone: +44 (0) 1729 821 080 \* sales@dccconcepts.com \* www.dccconcepts.com



Unique features, real performance and exceptional installability

<b>CV15</b>	Decoder UNLOCK #	Default = 0 (off)	Range = 1~255
<b>CV16</b>	Decoder LOCK#	Default = 1	Range = 1~255

Use CV 15 and CV 16 together to lock or unlock a ZEN decoder, a VERY useful thing if you have multiple decoders in one train and want to set functions differently, etc. (example, EMU or DMU with multiple power cars and lighting set up in the coaches). By using decoder lock, you can have the WHOLE TRAIN in the programming track and by using the selective locking and unlocking abilities of the decoder, reprogram one decoder at a time without affecting them all. A very useful thing indeed!

CV 15 holds the decoder-specific KEY numbers for the locking system. Setting CV15 to any number above 0 activates that key number and initiates decoder locking. The default is 0 which means locking is OFF.

CV16 is the decoder-specific LOCK number. It is already set to 1 (ONE) so it is ready for the first key by default.

Use CV16 first in order to set up the LOCK numbers in each decoder. (Ideally, do it prior to decoder installation). Allocate the CV16 number for each. We suggest that you start at 1, and set the subsequent decoders to 2, 3, 4, etc. (You can use any number sequence you want up to 255, but keep it simple as you'll need to remember them).

AFTER setting CV16, set CV15 on all decoders to be installed in that train to the first number in your CV16 sequence. Now install the decoders & prepare to program (The first decoder will already be unlocked if you used the above guide).

Set this decoder up as you want it to be then lock it again by changing its CV15 number to any number higher than the highest CV16 number in the sequence. (e.g. if you have 4 decoders with CV16 set to 1/2/3/4, then set CV15 to 5).

Now set the CV15 value in the second decoder to a value of 2 to match its CV16 number, and it will be unlocked. Program the decoder then change its CV15 number to 5 to lock it. Repeat this process with decoders 3 and 4 in the sequence.

At any point, you can go back and change CV15 so that it again matches CV16 to unlock and re-adjust any of the decoders. (NO programming can be done with a decoder locked including a CV8 = 8 reset. However, CV15 remains accessible, and with Zen decoders, if you DO forget the CV15 lock number, you can simply set CV15 to 0 (ZERO) to unlock the decoder)

<b>CV17</b>	Long Address (High and low byte)	Default = 0	Range = 1~255
<b>CV18</b>		Default = 0	Range = 1~255

Your controller will usually set the contents of CV 17 and CV 18 for you automatically when you choose to use a long address!

A long address can be anywhere between 0001 and 9999. (Note: in digital addressing, a zero is as valid as any other number, so while 3 is a short address, 0003 is long. Therefore never insert leading zeros unless you really DO want them there)

Recording a long address needs more memory than can be held in one CV so two are used.

There IS a way to calculate these numbers, however you should not really ever have to do it as fortunately your control system will do this for you automatically. If you are interested in how it is done and want to try to do it manually, please search online for "DCC long address calculator" and you will find several examples to look at and learn from.

Choosing the long address: Those new to DCC often use short addresses (set in CV1) in sequence, which is fine as long as you have only a couple of locos, but what happens when you have many - or run trains infrequently so numbers may be forgotten? We strongly recommend that you think about using long addresses, using the numbers allocated on the real thing and already printed on the cab-side of almost every model locomotive.

For many prototypes these are 4 digit addresses so they can be used directly. Others use longer numbers which are a combination of the loco class and its individual number or regional number plus individual number.... Either way, if you use them consistently as the basis for your "Long addresses", you will never forget a loco number again!

If you DO forget a loco number, you have two simple ways of recovering the loco using your controller. You can either put the loco on the programming track and "read" the decoder - or do a decoder reset, which will automatically reset the address to #3.



**Unique features, real performance and exceptional installability**

<b>CV19</b>	Consist Address	Default = 0	1~127
-------------	-----------------	-------------	-------

There are TWO types of consist. CV19 records the address for ADVANCED consist. Simple consists or “double heading” is handled entirely within the DCC controller, which temporarily allocates a standard CV1 short address to both locomotives.

We are discussing only “Advanced consist” here. A consist in this context is usually made up of two or more locomotives, selected to work together to handle a train temporarily. Once in a consist, the two locomotives will work together as one. More commonly used in places like USA or Australia where trains are larger and frequently require more than one locomotive, they are still used in other areas for heavy or special trains, so it is useful to understand how to create and address a consist.

Consist Addressing is similar to Short Addressing in that Zen decoders accept consist values from 1-127. You will have the choice of number from 1 to 127, but controller “Automatic assignment” of address will usually be in the range of 100 to 127.

If CV19 is set to ANY number other than 0, the decoder will consider itself to be within a consist and it will then only respond to drive commands that are sent to that consist number. The decoder WILL however still let you turn lights on and off by using the Loco’s original long or short address. Advanced consist is DCC standards based and a consist set up on your layout should therefore respond properly when taken to run on any layout, even if the DCC controller brand used there is different.

Setting up consists: All quality DCC controllers will have a process to set up your consists automatically. Controllers will vary slightly in the details of how they do it so please read your own controller manual before setting up an advanced consist.

<b>CV20</b>	This is not a user adjustable CV. Please do not attempt to use it.		
-------------	--------------------------------------------------------------------	--	--

<b>CV21</b>	Consist function control settings	Default = 0	See table below
<b>CV22</b>		Default = 0	See table below

These two CVs will manage which functions can be turned on or off when the decoder is in an advanced consist.

Normally your controller will assist you in arranging the lighting when an advanced consist is set up, so you will not need to bother with these two CVs at all. However if you want to attempt to set a consist up manually, you will need to use CV21 and CV22 to set the lighting up appropriately.

By default, none of the lights or functions that are controlled by a decoder can be turned on or off if you are using a “consist address” to identify the locomotive/decoder. You can add this ability by modifying values in CV21 & CV22.

Please use the chart below. Select the functions that you wish to be controllable when the locomotive is in a consist, then add up the numbers and enter that value into CV21 or CV22 as appropriate. For example, enter 3 into CV22 if you want Front (FL) and Rear (RL) lights to be controllable in a consist. Enter 7 into CV21 if you want Aux 1, Aux 2 and Aux 3 to be controllable.

<b>CV21</b>	Green wire or Function 3	(Aux 1)	1
	Purple wire or Function 4	(Aux 2)	2
	Brown wire or Function 5	(Aux 3)	4
	Pink wire or Function 6	(Aux 4)	8

<b>CV22</b>	White wire (Front/headlight)	FL or RL	1
	Yellow wire (Rear/tail light)	FL or RL	2



Zen Decoders are imagined, designed and manufactured by DCCconcepts Ltd  
 Our showroom and offices are located in Settle, North Yorkshire BD24 9RP, England  
 Phone: +44 (0) 1729 821 080 \* sales@dccconcepts.com \* www.dccconcepts.com





thinking outside the square  
concepts

**Unique features, real performance and exceptional installability**

<b>CV23</b>	Acceleration momentum trim	Default = 0	Range = 1~255
-------------	----------------------------	-------------	---------------

This is a simple adjustment for individual loco trimming to match locos when in a consist, etc. Zen decoders also offer a full 3-step trimming to adjust and trim locomotive momentum for acceleration. (See CV125 to CV132)  
It allows a trim or modification of the values in CV3 by adding or subtracting from it using the same rate equation. In reality, the actual values in CV3 never actually change. (CV23's purpose is to be a temporary adjustment for use with consisting, etc., as opposed to CV3 which is for permanent locomotive setup)

<b>CV24</b>	Deceleration momentum trim	Default = 0	Range = 1~255
-------------	----------------------------	-------------	---------------

This is a simple adjustment for individual loco trimming to match locos when in a consist, etc. Zen decoders also offer a full 3-step trimming to adjust and trim locomotive momentum for deceleration. (See CV125 to CV132)  
It allows a trim or modification of the values in CV4 by add or subtracting from it using the same rate equation. In reality, the actual values in CV4 never actually change. (CV24's purpose is to be a temporary adjustment for use with consisting etc as opposed to CV4 which is for permanent locomotive setup)

<b>CV25</b>	ONE STEP LOCO SETUP (Loco / train type presets)	Default = 0	See the table below
-------------	-------------------------------------------------	-------------	---------------------

ONLY available with DCCconcepts ZEN decoders. (From Software Version 12, Zen BLUE+ and BLACK decoders).  
A single change to CV25 will change 5 different decoder CVs, setting up your Zen decoder to act more like the prototype so that it and the trains it pulls will react more prototypically - making decoder setup MUCH easier.  
How does it work? When you change CV25, your ZEN BLUE+ or BLACK decoder will then automatically change the running settings in CV2, CV3, CV4, CV5 and CV6 all at once, so you do not need to worry about complex programming.  
Our suggestions are made using our test locos & preferences. You may wish to change some of them and we encourage you to do so if you wish. After using the pre-sets, you can if you want tune further, one CV at a time. Experiment & have fun.

<b>ZEN BLUE+ &amp; BLACK. ONE STEP LOCOMOTIVE SETUP WITH ZEN CV25</b>						
To simulate a loco/train that acts like the options below	SET CV25	Decoder settings will then become				
		CV2	CV3	CV4	CV5	CV6
DEFAULT SETTINGS	0	2	12	12	0	0
SHUNTING LOCO	1	2	4	4	72	24
LIGHT FREIGHT	2	2	6	6	84	32
HEAVY FREIGHT	3	2	18	24	96	40
EXPRESS FREIGHT	4	2	15	21	108	48
LIGHT ENGINE	5	2	4	4	96	40
LOCAL / BRANCH PASS.	6	2	12	12	96	40
STOPPING PASSENGER	7	2	15	18	108	36
EXPRESS PASSENGER	8	2	15	18	120	52
EMU or DMU	9	2	8	12	120	60

<b>CV26</b>	<b>CV28</b>	<b>CV30</b>	<b>CV31</b>	<b>CV32</b>	Not user adjustable CVs. Please do not attempt to use them.
-------------	-------------	-------------	-------------	-------------	-------------------------------------------------------------



Zen Decoders are imagined, designed and manufactured by DCCconcepts Ltd  
Our showroom and offices are located in Settle, North Yorkshire BD24 9RP, England  
Phone: +44 (0) 1729 821 080 \* sales@dccconcepts.com \* www.dccconcepts.com



**Unique features, real performance and exceptional installability**

<b>CV27</b>	ZEN AUTOMATION with SHUTTLE, ABC & BRAKE ON DC	Default = 0	Also see PART 3 of this manual
-------------	------------------------------------------------	-------------	--------------------------------

DCCconcepts have added considerably to the potential for automation within a decoder. CV27 is the core CV that sets the primary configuration for braking, slow down & ZEN SHUTTLE control with ABC. This takes several steps so we have moved all discussion of these CVs and their operation or adjustment to later in this manual (with helpful specific examples).

For more, please go to **PART 3: DCCconcepts ZEN BLACK decoders - ZEN Automatic braking with ABC and Brake on DC**

The basics for CV27: Select the actions that you want to implement from the left column. Add up the corresponding values from the right column and enter the resulting value into CV 27.

(Please note: The default asymmetrical DCC signal voltage difference value is 1.2V, but you can adjust detection sensitivity with CV 62 if "Auto Stop in the presence of an Signal Controlled Influence cut-out signal" is enabled)

**CV27 - Primary DCCconcepts ABC Function Settings, STOPPING or SHUTTLE. (Related options activate with CV55 CV56)**

DCCconcepts auto-slow down/stop when an ABC DCC Signal is detected. (More POSITIVE on ABC rail)	1
DCCconcepts auto-slow down/stop when an ABC DCC Signal is detected. (More NEGATIVE on ABC rail)	2
DCCconcepts Automatic ZEN SHUTTLE OPERATION with time adjustable stop period. (Adjust stop timing with CV59)	4
Automatically stop when in the presence of a signal control influence cut-out signal. (Adjust signal sensitivity with CV62)	8
<b>DCCconcepts ZEN Brake on DC option (Simplified "One rail only" Brake on DC activation - for both ZEN Blue+ &amp; Black)</b>	
Brake on DC if DCCconcepts BDC 1-rail DC rectification or (+) DC is detected (Voltage is POSITIVE on selected rail)	16
Brake on DC if DCCconcepts BDC 1-rail DC rectification or (-)DC is detected (Voltage is NEGATIVE on selected rail)	32

<b>CV29</b>	The PRIMARY decoder configuration & operational options	Default = 6	See table and descriptions below
-------------	---------------------------------------------------------	-------------	----------------------------------

CV29 is a clever CV that sets the primary configuration of the decoder. It is usually not necessary for you to make direct CV29 changes as all quality DCC systems will automatically change it to match your selections during initial decoder set-up.

You can edit it directly but please do NOT do so unless you have a basic understanding of CV29 actions, because a wrong setting will stop the decoder working properly. As a fall-back, if you make a change that results in a decoder not operating you can recover the decoder EITHER by a full CV8 = 8 reset. Alternatively, for a "simple direct fix" that will not affect other things - If the decoder had a short address, change CV29 to 2. - If the decoder had a long address, change CV29 to 32.

Your control system will usually set CV29 for you, depending on the options that you select during program track setup. If you want to know more about CV29, please search online for "DCC CV29 calculator" and you will find many options there.

**CV29 - The PRIMARY decoder basic configuration CV" - What it controls and basic setting information**

<b>Direction of operation of the decoder or locomotive:</b> 0 is normal, set this bit to 1 to swap forward and reverse	1
<b>14 or 28 Speed steps:</b> 0 = 14 speed steps, 2 = 28/128 speed steps, With few exceptions, you should ALWAYS leave this set to 2. (You can select between 28 and 128 speed steps via your controller. We recommend 128 for finer control)	2
<b>DC running option:</b> Leaving this at default will allow running when the decoder sees DC power on the rails. It must be turned OFF if you are using a Stay alive or wanting to use Zen Automatic braking, Zen Shuttle, ABC or Brake on DC Decoder runaways can happen when DC running is left engaged, so we recommend turning OFF (Choose 0 for this option)	4
<b>Railcom:</b> A proprietary Lenz option, we recommend Railcom is left OFF as it will usually be ignored by most systems	8
<b>Alternate Speed Curve:</b> This decoder has a default speed curve and it will also allow you to set your own custom 28 step speed curve using CV67 to CV94. To use the built in speed curve (recommended) you should leave this at 0	16
<b>Short or Long address:</b> If the decoder has an address between 1 and 127 set it to 0. For 128 to 1999 it should be 32	32

Choose the options you want, ADD the numbers for those options together and then enter that value into CV29

 Zen Decoders are imagined, designed and manufactured by DCCconcepts Ltd  
 Our showroom and offices are located in Settle, North Yorkshire BD24 9RP, England **10**  
 Phone: +44 (0) 1729 821 080 \* sales@dccconcepts.com \* www.dccconcepts.com



**Unique features, real performance and exceptional installability**

**CV33 to CV54** CV33 to CV54 are “Lighting and Function mapping” related CVs. See the ZEN manual PART 2.

DCCconcepts ZEN decoders have a huge range of lighting options. This may take several steps so we have moved all of the discussion of these CVs and their operation, their use or their adjustment to later in this manual (with helpful specific examples).

For more, please go to **PART 2: DCCconcepts ZEN BLUE+ and BLACK decoders - detailed lighting and function setup.**

**CV48** ABC Accel. delay if moving directly from a SLOW to a STOP section Default = 15 Range 1~255. Also see P29

When a loco moves directly from an ABC SLOW DOWN section to an ABC STOP section, there will be a short time period where the wheelbase is bridging both sections. This may cause it to accelerate slightly. This will vary by length of loco. To prevent this, we have added a “Time delay when leaving ABC SLOW option” using CV48. You can adjust it in 255 steps. Each step is equal to 0.1 seconds. The default is set at CV48 = 15 or 1.5 seconds. Adjust it individually to suit each of your locomotives.

**CV55 to CV 60** DCCconcepts ABC Braking adjustment CVs Default = Various Please see manual Part 3

DCCconcepts ZEN BLACK decoders have a uniquely sophisticated ABC control ability, allowing automated slowing and stopping with great accuracy. They are also able to carry out totally automatic shuttle operation with very simple set-up.

For more, please go to **PART 3: DCCconcepts ZEN BLUE+ and BLACK decoders for detailed ABC braking set-up.**

**CV61** BEMF on/off, Button control of BEMF, Button control of the MOTOR, Lights, Opposite Dim, etc. Default = 1

CV61 is a compound CV and able to influence the control of several things. This will need several numbers added together. The final total that you set into CV61 will dictate what the decoder will do in several areas. We will follow the various options and related CVs here and also add some chart to clarify things a little for you.

*By the way - before you adjust BEMF related things, be aware that it is rare that any running problems actually relate to BEMF.. Suspect cleanliness, loco power pickup or mechanism and their many possible binding points before changing things in the decoder software!*

**Turning Back EMF on and off:** Turning BEMF on and off - BEMF needs 1 added to CV61 to turn BEMF on. (The default is set to 1)

**Using CV61 to turn BUTTON CONTROL of BEMF on and off:** Button control of BEMF lets you turn BEMF on and off using a function button. Button control is OFF by default. To activate button control, 2 has to be added to the value that is currently in CV61.

You would change CV61 to a value of 3 to set BEMF on with button control. Button control of BEMF is already set up to be automatically controlled by your controllers Function 6 button. We chose to use Function 6 because F0~F5 are often used for other things.

You can, if you wish, re-map button control of BEMF to F5 ~ F12 by using CV136. Please refer to the CV136 chart.

**Activating “Opposite Dim” or “Dim lights when stopped” ability by adding to the value that is set in CV61:**

We need to activate opposite dim/dim when stopped so that “Rule 17” lighting can work. (Rule 17 is fully explained on page 23)

To activate “Dim when stopped” so that the lights dim when stopped, add 16 to the value already set into CV61

To activate “Opposite dim” so that the lights dim at the rear of the loco when stopped, add 32 to the value already set into CV61

**Activating function-button control of the motor by adding to the value that is already set into CV61:**

There are TWO forms of button control of the motor. “Manual control of motor circuit” and “Automatic control of motor circuit”.

These abilities make it possible to control devices such as turntables and lift bridges - and can also be used to control higher-powered accessories such as large smoke units that need power handling larger than normal decoder functions can manage.

**MANUAL push-button control is set by adding 64 to the value that is already set into CV61.**

Manual control means that the motor will move in one direction with F2 and in the other with F3.

Motor speed control when using manual push button control can be controlled by setting CV133.

**AUTOMATIC push-button control is set by adding 68 to the value that is already set into CV61.**

Automatic control means that the motor is turned on and off with function 2 and then the motor direction is controlled by the DCC controller direction buttons. Motor speed can be controlled by setting CV133. The function button choice can be chosen via the value that you set in CV134. See next page for CV134 chart



Zen Decoders are imagined, designed and manufactured by DCCconcepts Ltd  
Our showroom and offices are located in Settle, North Yorkshire BD24 9RP, England  
Phone: +44 (0) 1729 821 080 \* sales@dccconcepts.com \* www.dccconcepts.com

**Unique features, real performance and exceptional installability**

<b>CV61 data continued</b>	A chart based range of CV 61 optional settings that you can choose to use	Default = 1
BEMF on	BEMF is turned on at all times	1
BEMF with button control	BEMF can be turned on and off by using DCC controller Function button #6	2
Add "Dim when stopped"	Add 16 to whatever value you already have set into CV61	16+ existing #
Add "Reverse dim"	Add 32 to whatever value you already have set into CV61	32+ existing #
Add both Dimmer options	Add 48 to whatever value you already have set into CV61	48+ existing #
Add Manual Motor control	Add 64 to whatever value you already have set into CV61	64+ existing #
Add Automatic Motor Ctrl	Add 68 to whatever value you already have set into CV61	68+ existing #
Example for reference	BEMF on + BEMF button control + Dim when stopped = 1 + 2 + 16 = 19	Set CV61 to 19

Now CV61 is set, we can now move on to CVs 133, 134 and 136 to set how the motor will run and how it will be activated.

**CV133 sets the motor RPM/speed when CV61 has manual or automatic motor control enabled**

<b>CV61 has either 64 or 68 added to its current value</b>	Motor speed can be adjusted from 1 to 128 (direct equivalent to Speed steps)	Range 1~128
------------------------------------------------------------	------------------------------------------------------------------------------	-------------

When you use button control of the motor, you will want to set its speed. In both AUTOMATIC and MANUAL button control mode, motor speed can be set by changing CV133. The range will be 1 to 128, corresponding to the 128 speed steps available in the decoder.

**CV134 lets you choose which of the function buttons (0 ~ 4) you will use to start the motor with Automatic button control.**

Function Button choice	FWD 0	REV 0	1	2	3	4
<b>CV134 value should be</b>	1	2	4	8	16	32

With Automatic motor control, you control direction with the DCC controller Forward and Reverse buttons and activate the motor with a controller function.

The default is Function 2 because it is set to momentary with most controllers. (F2 only on while it is being pressed). If you want to change that, then use CV134 to select a different button for its operation. (Manual control of motor always uses F2 and F3)



**CV136 lets you choose which function button you want to use to turn Back EMF ON or OFF**

Function Button choice	5	6	7	8	9	10	11	12
<b>CV136 value should be</b>	1	2	4	8	16	32	64	128

Back EMF is on by default and will normally give excellent control, ensuring great slow running and slow starting as well as managing speed up and down hill - reducing slowing down on gradients and speeding up on the down hill run. Some modellers prefer to really drive their trains though, and using button control will give you the best of both worlds.

For example: Leave it on for a slow start, then turn it off with the simple press of a function button while driving so you really have to pay attention to train control... then re-engage it as the train comes to a stop. This can add to the interest for those who love realism!

Setting CV61 to 3 will activate button control using function 6. You can change which button you use using the CV136 chart above.



**Unique features, real performance and exceptional installability**

<b>CV65</b>	ZEN STAY ALIVE run time adjustment.	Default = 0 (Max)	1 to 4
-------------	-------------------------------------	-------------------	--------

To adjust how far your loco will go when a large “Stay Alive”™ is fitted to your loco:

This is a very simple to use CV setting. Default of 0 will allow the full run time available from the Stay Alive. Any setting from 1 to 4 will set a specific time. Each step is 0.5 seconds, so set to 1 = 0.5, set to 4 = 2.0 seconds. Please note that the actual run distance will of course vary depending on the power that is drawn by your loco, so not all locomotives will run the same distance on the same time setting.

<b>CV66</b>	Alternative BEMF motor mapping (Adjusted BEMF settings)	Default = 0	0 or 1
-------------	---------------------------------------------------------	-------------	--------

Use CV66 to adjust the overall influence of BEMF on your locomotive running characteristics:

DCCconcepts ZEN BEMF is pre-set & automatically adjusts for many motor types so generally needs little adjustment. However, some very low current or coreless motor types have significant differences so we have created a second BEMF range to accommodate them. Default of 0 in CV66 will leave the main BEMF structure active. This is suitable for most motor types. If you set CV66 to 1, it will lower the influence levels of BEMF, making them suitable for very small, high efficiency or coreless motors.

You can also turn BEMF off OR control BEMF on/off via a function button by setting the appropriate numbers into CV61 OR keep BEMF active only for starting locomotive / turn it off at a specific speed step with CV10.

<b>CV67 to CV94</b>	28 CVs that work together to create a 28-step customisable speed table	Default = 0	1 to 128
---------------------	------------------------------------------------------------------------	-------------	----------

Your ZEN decoder already has our preferred speed table active when you buy it. However, you may wish to use this optional speed table or create your own. To do this you will need to tell the decoder to use the “Alternative” speed table. This is done by reading CV29, then adding 16 to whatever number you find there. (For example, if CV29 is 32, add 16 to make it 48).

The range of all speed table CVs is 1~255. However you need to follow some simple rules when setting them to get a good result:

- Keep CV67 to 69 relatively low to ensure a smooth start.
- Keep the steps reasonably regular. It is OK to have them initially closer and growing, but large steps create jerky speed transitions.
- The lowest CV value must be CV67. Each CV must be equal to or larger than its predecessor.
- You CAN reach 255 earlier than CV94 but if you do, all CVs after the first CV that reads 255 must also be set at 255.

CV #	Speed Step #	Default	Your #
CV67	Speed Step 1	1	
CV68	Speed Step 2	10	
CV69	Speed Step 3	19	
CV70	Speed Step 4	29	
CV71	Speed Step 5	38	
CV72	Speed Step 6	48	
CV73	Speed Step 7	57	
CV74	Speed Step 8	66	
CV75	Speed Step 9	76	
CV76	Speed Step 10	85	
CV77	Speed Step 11	95	
CV78	Speed Step 12	104	
CV79	Speed Step 13	113	
CV80	Speed Step 14	123	

CV #	Speed Step #	Default	Your #
CV81	Speed Step 15	132	
CV82	Speed Step 16	142	
CV83	Speed Step 17	151	
CV84	Speed Step 18	160	
CV85	Speed Step 19	170	
CV86	Speed Step 20	179	
CV87	Speed Step 21	189	
CV88	Speed Step 22	198	
CV89	Speed Step 23	207	
CV90	Speed Step 24	217	
CV91	Speed Step 25	226	
CV92	Speed Step 26	236	
CV93	Speed Step 27	245	
CV94	Speed Step 28	255	



**Unique features, real performance and exceptional installability**

<b>CV95 to CV111</b>	These CVs are not user adjustable. Please do not attempt to change them.		
<b>CV112 to CV122</b>	This set of CVs is part of ZEN lighting control. Please see PART 2 of this manual		
<b>CV123 to CV124</b>	These CVs are not user adjustable. Please do not attempt to change them.		
<b>CV125 to CV132</b>	ZEN 3-Step DECELERATION and ACCELERATION adjustment	Default = 0	See Notes

Trains and locomotives are large, heavy things and the way they accelerate is quite distinctive case by case, with heavy freight trains having quite different characteristics to lighter trains such as passenger DMU or EMU units for example. Apart from the obvious slower start with increasing acceleration as speed builds, slow down is also influenced by the need to keep constant weight on couplers when braking OR of course, to keep passengers comfortable.

Realism matters to many of us, so our ZEN decoder can also have a variable acceleration or deceleration curve. With CV3 and CV4 already set, these will form steps 1 & 6 for the lower part of the acceleration/deceleration curves. The mid and top rate of change will be controlled by CV125 to CV132. Please refer to this chart to see the concept visually. Experiment and have fun.

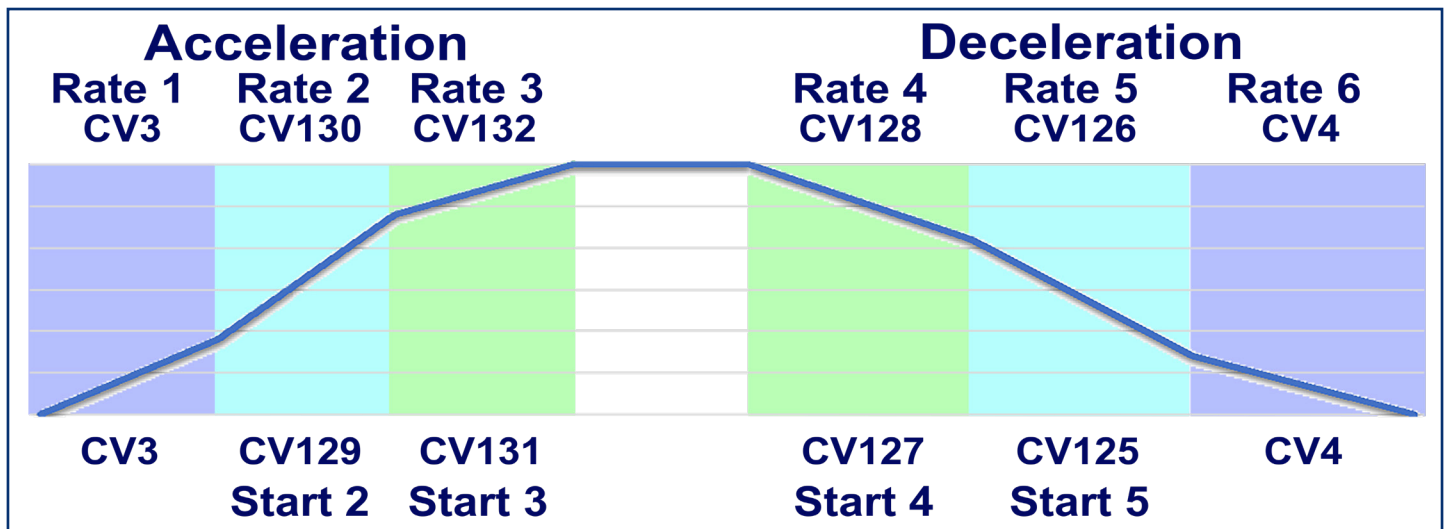

<b>CV133</b>	Adjust the motor speed when it is under function button control (See CV61 etc)	Default = 0	1 to 128
--------------	--------------------------------------------------------------------------------	-------------	----------

Adjusting this CV will let you set the motor run speed OR the operating voltage of a device that is connected to the DECODER MOTOR DRIVE CIRCUIT if you are controlling it via a function button. (Please refer to CV61 and other information on the CV61 page for detailed information on how to initiate button control).

The available range for this CV is 1 to 128. (The steps relate to the 128 available speed steps). Each step will be approximately 1/128th of track voltage. At 16v this is 0.125v per step.

<b>CV134</b>	Function assignment for button control of a motor or other device	Default = 0	See chart
--------------	-------------------------------------------------------------------	-------------	-----------

The basic details are in this chart: *More detail can be found on pages 11 and 12 which detail the various settings for CV61 use.*

Function Button choice	FWD 0	REV 0	1	2	3	4
<b>CV134 value should be</b>	1	2	4	8	16	32

<b>CV137 ~ CV139</b>	<b>CV142 ~ CV143</b>	<b>CV149 ~ CV255</b>	These three CV groups are not user adjustable.
----------------------	----------------------	----------------------	------------------------------------------------



**Unique features, real performance and exceptional installability**

### Stay-Alives and Zen Decoders.

Our Zen Blue+ and Black decoder range now has a really strong “Brown out” prevention ability built in so we no longer pack a Stay-Alive with every decoder.

We also know that track will not always be perfect and that some locos have “less than good” pickup ability, so we have, at the same time, made the optional installation of Stay-Alives very simple indeed. In fact, installing one of our new Stay-Alive range is now, more often than not, a simple plug-and-play option!

With our large-scale “Zen Buddha” decoder we have gone one step further: Large scale is often used outdoors or on larger layouts where track ckeaning isn’t easy - so a high power “Stay-Alive” is already fitted to the decoder.

### The super-installable Zen Stay-Alive range.

Stay-Alive design requires some conflicting issues to be resolved.

Users often want larger capacity for longer power delivery. This means greater size... which means larger capacitors.

This in turn also needs more careful power control as “super capacitors” cannot handle higher voltages. That adds various electronic items that we also need to find space for - inside a loco - a place that usually has none to spare!

So... we need to make them bigger - but we also need to keep them simple to apply and installable by modellers who want the best but may not have great soldering skills... or the confidence to work with fine wiring.

We have achieved that by changing the way we approach their creation. The following details will tell the story.

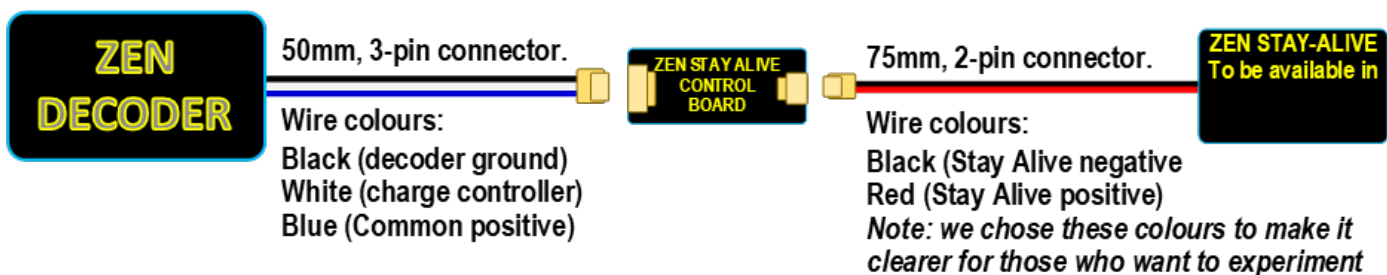

Zen Decoders are imagined, designed and manufactured by DCCconcepts Ltd  
 Our showroom and offices are located in Settle, North Yorkshire BD24 9RP, England  
 Phone: +44 (0) 1729 821 080 \* sales@dccconcepts.com \* www.dccconcepts.com



## Unique features, real performance and exceptional installability

### Part 2: DCCconcepts BLUE, BLUE+ and BLACK decoders

#### LIGHTING CONTROL: Advanced options plus function button re-mapping abilities and function set-up.

The **Zen** Decoder range has always had full function re-mapping ability and a huge range of more than 30 different lighting control options. Our BLUE+ and BLACK Series decoders build on this giving you the best lighting ability available.

Some light settings will involve both re-mapping of functions and specific allocation of light effects to CVs, so we will group the CVs with the light functions being described, rather than list the CVs in number order. This should let you set up any function completely without having to jump back and forth to find the appropriate CVs for each effect.

*(While we wrote this manual for our version 12+ BLUE+ or BLACK decoders, you may also use this instruction set for setting up of most lighting options and function mapping on previous Zen decoder versions - if there is a setting that is available only for version 12+ BLUE+ or BLACK, we will note this within the instructions)*

#### CVs 33 to 42

Function mapping for all active / powered functions

Default = See Chart

Range = See Chart

This group of CVs lets you decide which function button will turn each of the coloured “powered function” wires on and off.

*When working with function button allocation, do not forget that SOME function buttons in your controller will be set as momentary switches rather than as “Press for on and Press for off”. F1 is often set this way, as it is frequently used for the “Whistle or Horn button” in sound decoders. To change this action you will of course need to refer to your controller manual.*

\* The CV numbers in this chart are not sequential - we have grouped them in “wire colour order” to keep it simpler for you.

\* Usually directional operation will be set when you select a “lighting action” for any wire/function (see the light functions chart a little later on in this manual). However, there is a place in this chart that does have directional action. If you allocate ANY wire to F0-F or F0-R by setting its CV to 1 or 2 (usually reserved for lights/headlights or F0 / Function 0 button) then the wire/function will only operate when the locomotive is set to move in the correct direction via a DCC controller command.

\* Yes, you can make a wire operate from more than one function button. To do this, add the numbers for the selected buttons.

For example, if you set CV35 (Green wire) to 20 it will work with both function 1 (CV35=4) and function 3 (CV35=16) buttons.

\* We do recommend that you keep all function allocations in the F0~F9 range so that they are more easily selected while “driving”.

CV #	Colour	Output (Decoder Wire)	Default	F0(F)	F0(R)	F1	F2	F3	F4	F5	F6	F7	F8	F9	F10	F11
CV33	White	Forward light (or F1)	1	1	2	4	8	16	32	~	~	~	~	~	~	~
CV34	Yellow	Reverse light (or F2)	2	1	2	4	8	16	32	~	~	~	~	~	~	~
CV35	Green	Aux 1 (F3) = for button 0~4	4	1	2	4	8	16	32	~	~	~	~	~	~	~
CV37	Green	Aux 1 (F3) = for button 5~11	0	~	~	~	~	~	~	1	2	4	8	16	32	64
CV36	Purple	Aux 2 (F4) = for button 0~4	8	1	2	4	8	16	32	~	~	~	~	~	~	~
CV38	Purple	Aux 2 (F4) = for button 5~11	0	~	~	~	~	~	~	1	2	4	8	16	32	64
CV39	Brown	Aux 3 (F5) = for button 0~4	16	1	2	4	8	16	32	~	~	~	~	~	~	~
CV41	Brown	Aux 3 (F5) = for button 5~11	0	~	~	~	~	~	~	1	2	4	8	16	32	64
CV40	Pink	Aux 4 (F6) = for button 0~4	32	1	2	4	8	16	32	~	~	~	~	~	~	~
CV42	Pink	Aux 4 (F6) = for button 5~11	0	~	~	~	~	~	~	1	2	4	8	16	32	64



Zen Decoders are imagined, designed and manufactured by DCCconcepts Ltd  
 Our showroom and offices are located in Settle, North Yorkshire BD24 9RP, England **16**  
 Phone: +44 (0) 1729 821 080 \* sales@dccconcepts.com \* www.dccconcepts.com





**Unique features, real performance and exceptional installability**

**CV47** One-Step, easy to set-up “Fluorescent Flicker” lighting effects    Default =0    Settings range = See Chart

This CV lets you set up the effect of “flickering fluorescent lighting” in your passenger coaches, EMUs or DMUs. Rather than needing to set up to six functions separately, this is done with a simple change in just one CV. You can choose from fully automatic operation for all lights (CV47=1), automation without directionality (CV47=2), semi-automatic operation (CV47=3) or, if you wish, make all functions flicker independently by setting CV47=4. Details are in the table below.

CV#	Set CV to	Default Controller Button	Output designation (Decoder wire)	Light effect that occurs when “Fluorescent flicker” is activated (will change if you re-map the control buttons)
CV 47	1	F0 (Head light)	F0-F / F1 (White)	Turns on steadily with NO Flicker when F0-Forward button is selected
			F0-R / F2 (Yellow)	Turns on steadily with NO Flicker when F0-Reverse button is selected
			AUX1 (F3) (Green)	Flickers randomly at turn-on, then stabilises (irrespective of F0 direction)
			AUX2 (F4) (Purple)	Flickers randomly at turn-on, then stabilises (irrespective of F0 direction)
			AUX3 (F5) (Brown)	Flickers randomly at turn-on, then stabilises (irrespective of F0 direction)
			AUX4 (F6) (Pink)	Flickers randomly at turn-on, then stabilises (irrespective of F0 direction)
CV 47	2	F0 (Head light)	F0-F / F1 (White)	Flickers randomly at turn-on, then stabilises (irrespective of F0 direction)
			F0-R / F2 (Yellow)	Flickers randomly at turn-on, then stabilises (irrespective of F0 direction)
			AUX1 (F3) (Green)	Flickers randomly at turn-on, then stabilises (irrespective of F0 direction)
			AUX2 (F4) (Purple)	Flickers randomly at turn-on, then stabilises (irrespective of F0 direction)
			AUX3 (F5) (Brown)	Flickers randomly at turn-on, then stabilises (irrespective of F0 direction)
			AUX4 (F6) (Pink)	Flickers randomly at turn-on, then stabilises (irrespective of F0 direction)
CV 47	3	F0-F	F0-F / F1 (White)	Turns on steadily with NO Flicker when F0-Forward button is selected
		F0-R	F0-R / F2 (Yellow)	Turns on steadily with NO Flicker when F0-Reverse button is selected
		F1	AUX1 (F3) (Green)	Flickers randomly at turn-on then stabilises (if AUX1’s control button selected)
		F2	AUX2 (F4) (Purple)	Flickers randomly at turn-on then stabilises (if AUX2’s control button selected)
		F3	AUX3 (F5) (Brown)	Flickers randomly at turn-on then stabilises (if AUX3’s control button selected)
		F4	AUX4 (F6) (Pink)	Flickers randomly at turn-on then stabilises (if AUX4’s control button selected)
CV 47	4	F0-F	F0-F / F1 (White)	Flickers randomly at turn-on then stabilises (if F0-F control button is selected)
		F0-R	F0-R / F2 (Yellow)	Flickers randomly at turn-on then stabilises (if F0-R control button is selected)
		F1	AUX1 (F3) (Green)	Flickers randomly at turn-on then stabilises (if AUX1’s control button selected)
		F2	AUX2 (F4) (Purple)	Flickers randomly at turn-on then stabilises (if AUX2’s control button selected)
		F3	AUX3 (F5) (Brown)	Flickers randomly at turn-on then stabilises (if AUX3’s control button selected)
		F4	AUX4 (F6) (Pink)	Flickers randomly at turn-on then stabilises (if AUX4’s control button selected)



Zen Decoders are imagined, designed and manufactured by DCCconcepts Ltd  
 Our showroom and offices are located in Settle, North Yorkshire BD24 9RP, England **17**  
 Phone: +44 (0) 1729 821 080 \* sales@dccconcepts.com \* www.dccconcepts.com



**Unique features, real performance and exceptional installability**

The **Zen** Decoder range has incredibly versatile lighting abilities.

Please DO experiment with lighting - No matter which prototype or time period you model, we've included light effects to do it all, from the random flicker of an oil lamp to automatic dim, auto and manual rule 17, ditch lights and many other effects.

Its good to experiment and learn about new things - and do not worry... You cannot harm your decoder while experimenting!

As always, defaults are listed so that you can easily re-set any specific CV if things go wrong - and of course, if you just want to start again, CV8 = 8 will take your decoder back to its ex-factory defaults in all areas. An easy fix if you get completely lost along the way.

**CVs 49 to 54** Allocating light functions to specific function wires    Default = See Charts    Range = See Charts

This group of CVs allocates specific light effects to specific function wires. In general it is quite a simple process, however, because rule 17 lighting and ditch lights require the use of active function wires PLUS use of a specific decoder button to activate them, there are some simple rules to be observed when setting up your decoder for those two light functions.

\* IF activating Rule 17 lighting, please do not allocate any other lighting wire operation to controller function button 4, as it is needed for manual control of Rule 17 headlight dimming.

\* IF activating ditch lights, please do not allocate any other lighting wire operation to controller function buttons 2 or 5 as these two functions are pre-allocated to control the ditch light flash.

\* If you are not setting up Rule 17 or ditch lights, you may use any function button to activate any of the function wires.

**Specific examples for complex lighting:**

The next two general charts cover the CVs activating lighting effects for each of the active function wires and the values needed to activate them in forward, reverse or bi-directional modes. However complex light functions also have adjustments for light brightness and flash frequency (additionally, with Mars and Rule 17 etc, there are even speed-related changes to lighting activity).

We have, therefore, also added a special example for each of these more complex options.

**Directionality and default setting:**

Each active function can be set to be directional - or to stay on in either direction. The default is as shown below. In all cases, the lights are set to "constant bright light" by default.

CV #	Colour	Output wire name	Default Setting	Actions if left at the default setting
CV 49	White	F0-F (F1)	0	0 = On when in FORWARD direction only
CV 50	Yellow	F0-R (F2)	16	16 = On when in REVERSE direction only
CV 51	Green	Aux 1 (F3)	32	32 = On in BOTH directions
CV 52	Purple	Aux 2 (F4)	32	32 = On in BOTH directions
CV 53	Brown	Aux 3 (F5)	32	32 = On in BOTH directions
CV 54	Pink	Aux 4 (F6)	32	32 = On in BOTH directions



Zen Decoders are imagined, designed and manufactured by DCCconcepts Ltd  
Our showroom and offices are located in Settle, North Yorkshire BD24 9RP, England **18**  
Phone: +44 (0) 1729 821 080 \* sales@dccconcepts.com \* www.dccconcepts.com



**Unique features, real performance and exceptional installability**

**CVs 49 to 54** General CV 49 to CV 54 setting values for specific special lighting features and effects

Lighting feature description	FWD	REV	BOTH	Notes related to each special light effect.
Constant BRIGHT Light	0	16	32	<i>These are the default setting on all decoder functions</i>
Random Flicker	1	17	33	<i>You can adjust random flicker rate with CV135. Default = 32.</i>
Mars Light Effect	2	18	34	<i>Adjustments with CVs 112 to 116. See separate description.</i>
Flashing Light	3	19	35	<i>Adjustments with CVs 144 to 145. See separate description.</i>
Strobe - Single Pulse	4	20	36	<i>Adjustments with CVs 140 to 141. See separate description.</i>
Strobe - Double Pulse	5	21	37	<i>Adjustments with CVs 146 to 148. See separate description.</i>
Rotary Beacon Effect	6	22	38	<i>Adjustments with CVs 118 to 122. See separate description.</i>
Gyra Light Effect	7	23	39	<i>Adjustments with CVs 112 to 116. See separate description.</i>
Rule 17 Lighting (dimmable)	8	24	40	<b>Also need to set CV61.</b> Rule 17 always needs Controller function 4 for dimming. Also see the separate description.
Ditch Light Phase A	10	26	42	<i>Ditch lights always need to use Controller Functions 4 and 5 The Ditch light timers are CVs 63 (Ditch lights "Stay on" timer) and 117 (Phase A and B Alternation frequency). Please also see the separate description for ditch light set-up.</i>
Ditch Light Phase B	11	27	43	
Constant DIM Light	12	28	44	<i>Adjustment of level with CV64. The default setting is 4.</i>
Automatic Mars Light Effect	13	29	45	<i>Adjustments with CVs 112 to 116. See separate description.</i>

**Specific Instructions: Random Flicker.**

Random flicker is effective for oil or gas lamps and lighting in early locos - as well as for representing TV screen flicker, fires or industrial lighting in buildings, etc. In fact, it can very cost-effective to use Zen loco decoders in buildings for simple control of multi-room light control OR to perhaps link one to illuminated buffer stops in a yard, adding the "random flicker" to one or two of them to represent those lamps that are in need of trimming!

- \* Set the chosen function wires CV to 1 for Forward only, 17 for Reverse only or 33 for on in both directions.
- \* If you want to change the "Random Flicker" rate, then adjust CV135.
- \* CV135 overall range is 1~255. Initially try adding in 10's then refine changes until you get the effect you want.
- \* CV135 default setting is 32.



Zen Decoders are imagined, designed and manufactured by DCCconcepts Ltd  
 Our showroom and offices are located in Settle, North Yorkshire BD24 9RP, England **19**  
 Phone: +44 (0) 1729 821 080 \* sales@dccconcepts.com \* www.dccconcepts.com



thinking outside the square  
concepts

## Unique features, real performance and exceptional installability

### Specific Instructions: MARS lights.

Mars Lights are signal-safety lights used in the United States and built by the Mars Signal Light Company for railroad locomotives and firefighting apparatus. Mars Lights used various means to cause the light to oscillate vertically & horizontally to catch the attention of motorists and pedestrians.

Initially seen on US railroads during the 1930's, Mars lights still exist today. They were fitted to both diesel and steam locos, with some preserved steam locomotives also having them fitted when they are restored.

These lights used several methods to physically oscillate the light beam.

Sometimes the bulb and assembly were moved, other times a reflector was rotated. The Mars beam was usually oscillated in a triple eight pattern, i.e., the beam would oscillate up and down two or more times for every horizontal sweep, with this light pattern providing the source for the company's slogan "The Light from Mars". Mars lights are steadily being replaced by Ditch lights. A Mars light can be seen in this loco image.

ZEN decoders are able to simulate Mars lights by adjusting the brightness & pulse rates of LEDs in a variety of ways. Clever installation using 2 functions can also result in a red/white Mars light as used by some US railroads.

Note: Mars lights and Gyalights both share the same CV adjustment set.



MARS & GYRALIGHT	CV #	Default	Range	Comment and notes.
<b>NOTE: All values must be set to above Zero. Min, Mid and Max cannot be the same and of course they must have values in an ascending order - i.e. minimum always lowest, maximum always highest and mid in between them.</b>				
Minimum Brightness	CV 112	1	1~25	Always 1 or higher as Mars lights are never fully off.
Maximum Bright time	CV 113	9	1~255	This CV Sets how long the light will remain at its full brightness level within the light cycle.
Total Light Cycle time	CV 114	1	1~3	Increases length of the total light cycle before repeating.
Mid Brightness Level	CV 115	6	1~25	Adjust to suit the Mars or Gyalight you want to create.
Max Brightness level	CV 116	22	1~25	Set above 20 - Mars light full brightness is always high.

### MARS or GYRA Lights.... What's the difference?

Both were electro-mechanical warning lights, sometimes mounted within a standard headlight structure.

Both were standard lights at normal train operating speeds but dropped into "Special light mode" when activated by lower speed or when approaching grade crossings / within yards, etc. (Please research your own prototype for the correct Mars/ Gyra operational rules).

While Mars lights tended to describe a "Figure eight" pattern, Gyalight tended to use a more circular light pattern. There are some excellent You Tube videos which show both of these interesting light effects in close-up.



Zen Decoders are imagined, designed and manufactured by DCCconcepts Ltd  
Our showroom and offices are located in Settle, North Yorkshire BD24 9RP, England **20**  
Phone: +44 (0) 1729 821 080 \* sales@dccconcepts.com \* www.dccconcepts.com



**Unique features, real performance and exceptional installability**

### **Setting up manually controlled Mars lights:**

As you can see in the photograph (page 20), MARS lights were usually mounted separately to the headlight. This was the case with both steam & diesel locos. In this example (for a diesel) we will add two of them, one to each end. Because we want **ONLY** the Mars light at the leading end to work, we will make both of them directional. We will use Green (Aux 1 / F3) for the front Mars light, and Purple (Aux2 / F3) for the rear Mars light in this example. Of course, if you have a 6-fn decoder, you could also choose to use Brown or Pink if you like.

\* Set the Green wire light effect CV (CV51) to MARS in Forward only. CV51 = 2.

\* Set the Purple wire light-effect CV (CV52) to MARS in Reverse only. CV52 = 18.

Usually MARS lights were operated at slower speeds in areas where additional warnings were needed and at road rail or grade crossings (just as ditch lights are used today). We want to keep operation simple so we want BOTH of these function wires to be controlled by the same function button. We will allocate them to Function 3.

\* Allocate the Green (Front Mars) wire to Controller function 3 by setting CV35 to 16.

\* Allocate the Purple (Rear Mars) wire to Controller function 3 by setting CV36 to 16.

Now... If you press Function 3, the MARS light that is on the "Forward end" of the locomotive will turn on. It will operate until you turn it off by pressing Function 3 again.

**Try it... If you want to change the way the MARS light acts and looks, you can use the 5 step "Mars and Gyalight" adjustment chart shown on page 20 to alter the light actions to your own preference.**

### **Setting up Automatic and Semi-automatic Mars lights:**

Many US and other railroads world-wide ruled that Mars lights were to be used during most low speed movements, so if you just want the Mars Lights to automatically turn on at slower running speeds, you can do that too.

Auto-Mars set-up is VERY similar to manual. We will again use Green (Aux 1 / F3) for the front Mars, and Purple (Aux2 / F3) for the rear Mars light. If you have a 6-fn decoder, you could also choose to use Brown or Pink if you like.

\* Set the Green wire Auto-Mars light effect CV (CV51) to "Active when moving forward" only. CV51 = 13.

\* Set the Purple wire Auto-Mars light-effect CV (CV52) to "Active when in reverse" only. CV52 = 29.

**Now you have another choice: have them come on with the headlights OR be activated by a separate function.**

**For Auto-Mars lights that only flash at slower speeds and with On/Off via the "Lights" function or F0, set as follows:**

\* Set the Green (front Mars) wire to turn on at the same time as the lights - Set CV 35 to 1.

\* Set the Purple (rear Mars) wire to turn on at the same time as the lights - Set CV 36 to 2.

**For Auto-Mars lights that only flash at slow speed and with On/Off via another function (example uses F3) set as follows:**

\* Allocate the Green wire (Front Mars) to F3 ~ the DCC Controller F3 function - by setting CV35 to 16.

\* Allocate the Purple wire (Rear Mars) to F3 ~ the DCC Controller F3 function - by setting CV36 to 16.

**Now... If you press Function 3, the MARS light that is on the current "Forward end" of the locomotive will turn on.**

**And...**

\* It will operate as a MARS light if you drop below speed step 43 (in 128 step mode) or speed step 10 (in 28 step mode).

\* It will operate as a normal second headlight if you are above speed step 32 / speed step 8 in 28 step mode.



Zen Decoders are imagined, designed and manufactured by DCCconcepts Ltd  
Our showroom and offices are located in Settle, North Yorkshire BD24 9RP, England  
Phone: +44 (0) 1729 821 080 \* sales@dccconcepts.com \* www.dccconcepts.com



**Unique features, real performance and exceptional installability**

**Specific Instructions: Simple FLASHING Lights.**

This type of light is more common on industrial or similar locomotives, and, while there are safety standards for flash rates, etc, they have varied over time, so again, please research your chosen prototype if necessary to find the ideal settings for your own models.

Of course flashing lights are seen everywhere and on anything requiring safety, not just locomotives...

Simple FLASHING Light	CV #	Default	Range	Comment and notes.
NOTE: All values to be set to above Zero. Unlike strobes or pulsed lamps, flashers have a distinct "on and off" cycle.				
Light ON duration	CV 144	144	1~255	Adjust in steps of 10~20 initially, then refine your choice.
Light OFF duration	CV 145	48	1~255	Adjust in steps of 10~20 initially, then refine your choice.

**Specific Instructions: Single phase STROBE Lights.**

This type of light will tend to be roof mounted rather than in the headlight position.

There are safety standards for flash rates and light levels etc, but they have varied over time, so please research your chosen prototype if it is important to you to get it right.

Of course strobe lights are seen in many places and on anything requiring safety warnings, not just locos...

SINGLE PULSE Strobe	CV #	Default	Range	Comment and notes.
NOTE: All values to be set to above Zero. Pulsed strobe lights go from high to low levels and are never totally off.				
Light OFF duration	CV 140	200	1~255	Adjust in steps of 20 initially, then refine your choice.
Light ON duration	CV 141	20	1~255	Adjust in steps of 10 initially, then refine your choice.

**Specific Instructions: Double phase STROBE Lights.**

This type of light tends to be roof mounted rather than in the headlight position. The double pulse is very effective.

There are safety standards for flash rates and light levels etc, but they have varied over time, so please research your chosen prototype if it is important to you to get it right.

Double-phase flashing lights are gain seen in may places as safety warnings, not just on locomotives...

DOUBLE PULSE Strobe	CV #	Default	Range	Comment and notes.
NOTE: All values to be set to above Zero. Pulsed strobe lights go from high to low levels and are never totally off.				
Strobe long OFF duration	CV 146	200	1~255	Adjust in steps of 20 initially, then refine your choice.
Strobe Light ON duration	CV 147	20	1~255	Adjust in steps of 10 initially, then refine your choice.
Strobe short OFF duration	CV 148	50	1~255	Adjust in steps of 10 initially, then refine your choice.



Zen Decoders are imagined, designed and manufactured by DCCconcepts Ltd  
 Our showroom and offices are located in Settle, North Yorkshire BD24 9RP, England  
 Phone: +44 (0) 1729 821 080 \* sales@dccconcepts.com \* www.dccconcepts.com



**Unique features, real performance and exceptional installability**

**Specific Instructions: ROTATING beacon.**

This type of light will also tend to be roof mounted rather than in the headlight position. They can also found on the top of tall towers and buildings aviation obstruction/warning lights.

A rotating beam is actually an electro-mechanical device, so accurately simulating a realistic rotating beacon is a complex thing to do. Therefore, there are six CVs that will need to be adjusted.

Always quite common, simple rotating beacons are still used in many applications...

DOUBLE PULSE Strobe	CV #	Default	Range	Comment and notes.
NOTE: All values are usually set to above Zero. This is because we need to simulate a light that is constantly on but is set into a rotating reflector, so the light will go from higher to lower levels but the overall glow will rarely be totally off.				
Rotary Minimum brightness	CV 118	1	1~25	Adjust in steps of 3 initially, then refine your choice.
Rotary MAX brightness TIME	CV 119	5	1~255	Adjust in steps of 10~20 initially, then refine your choice.
Rotary TOTAL CYCLE time	CV 120	1	1~3	This is the time for ONE FULL ROTATION.
Rotary MID-point brightness	CV 121	15	1~25	Adjust in steps of 3 initially, then refine your choice.
Rotary MAXIMUM brightness	CV 122	25	1~25	Adjust in steps of 3 initially, then refine your choice.

**Specific Instructions: RULE 17 LIGHTING.**

First, let's describe Rule 17 and what it means.

Rule 17 is part of a collection of rules that govern which lights are to be illuminated on a locomotive at given times and it also relates to when they should be dimmed.

These rules may vary slightly from railroad to railroad but generally follow a similar pattern.

The general purpose of Rule 17 is to make sure that the locomotive is visible, without creating undue glare that will negatively affect the safety of others that are operating in the area.

Basically...

Except when an engine is clear of the main and stopped, both the front (and rear if the loco has one) headlights should be turned on. Also - ONLY the light in the direction of travel should be at full brightness except when:

- \* The locomotive is at stations and yards where switching is being done.
- \* When the locomotive is stopped close behind another train.
- \* In non-signalled (dark) territory, when the engine is stopped on the main track waiting for an approaching train.
- \* When approaching and passing the head end and rear end of any train on the adjacent track.
- \* At other times to permit passing of hand signals or if required for employee safety. (When opposite light should be dimmed).

Note:

Rule 17 is commonly used as the model railroading term, and was the traditional prototype number for this rule. However, it has now been superceded in the real world. (It is now usually covered in USA in Rule 5.9.1 to 5.9.4.)



Zen Decoders are imagined, designed and manufactured by DCCconcepts Ltd  
Our showroom and offices are located in Settle, North Yorkshire BD24 9RP, England **23**  
Phone: +44 (0) 1729 821 080 \* sales@dccconcepts.com \* www.dccconcepts.com



## Unique features, real performance and exceptional installability

### Setting locomotive lighting up ready for “Rule 17” operation.

Rule 17 Dimming includes three different types of functionality:

These are: (1) Opposite Dim. When the loco is moving forward the reverse light is dimmed, and when travelling in the reverse direction, the forward light will be dimmed. (2) Dim the lights when stopped. When a loco comes to a complete stop the light(s) will dim. (3) Function button controlled dimming using Controller function button #4.

*Note: Button controlled dimming is in place by default any time that any lighting function is assigned to the Rule 17 lighting effect, however, Opposite Dim and Dim when Stopped must also be enabled in CV 61 before they can affect the decoders operation. See the tables & example below for more information on enabling Rule 17 Options.*

SETUP for RULE 17 with CV61	Default	Comment and notes.
NOTE: CV61 is a complex CV. ADD TOGETHER the values shown below as needed and enter that total into CV61.		
Enable BEMF	1	If 1 is NOT added in, BEMF will be turned OFF.
Enable BUTTON control of BEMF	2	If 2 is added in, then you can control BEMF with a function button.
DIM the lights when stopped	16	All lights assigned to Rule 17 operation will dim when the loco stops.
DIM the OPPOSITE light	32	The light at the rear of the locomotive will be dimmed.

### Specific examples for decoder set-up with “Rule 17” operation:

**Example 1:** Automatic “Rule 17” - This sets up the decoder so Rule 17 is automatic, head & tail lights stay directional and change automatically with the F0 or “Lights” function activated. Manual F4 operation of Rule 17 is still available.

- \* The light that is at the front of the locomotive will now automatically dim when the locomotive stops.
- \* The light that’s at the front of the locomotive can be dimmed at ANY time by pressing the DC Controller’s function 4 button at any time (for example, when shunting / switching beside the main line or moving within the loco depot)

Step 1: Activate “Dim the lights when stopped” by setting CV61. BEMF has CV61 already set to 1, so we will need to add 16 to that for “Dim when stopped”. Therefore, we will set CV61 to  $1+16 = 17$ .

Step 2: Set the dimming level by setting CV64. The default for CV64 is set to 4. CV64’s range is 1~15.

*Please note: we quite like a strongly dimmed light for this effect - so we will set CV64 to 1. (Results vary a bit by LED type/brand. Experiment with the 1~5 range and find your own preference)*

Step 3: Set the “light effect” requirement CVs for the WHITE and YELLOW function wires.

- \* CV49 allocates a light function to the WHITE wire. CV50 allocates a light effect function to the YELLOW wire.
- \* The RULE 17 activation options are 8 (forward only), 24 (reverse only) and 40 (non-directional). We suggest that for simple auto-operation + F4 control, you use 8 for CV49 (white wire) and 24 for CV50 (yellow wire).

**Example 2:** Manual control of “Rule 17” operation. We will just summarise this here.

- \* Leave CV61 at 1 or, if you want opposite dim but with manual control, set it to 33.
- \* Allocate White (front headlight) to F0, Yellow (rear headlight) to F1. If you want added lights also Rule 17 linked, then also Green to F2 and Purple to F3 (Chart on Page 16).
- \* Set each wire for rule 17 operation. (Wire operation CV numbers are on page 18. Also see Rule 17 values on page 19)  
Now you can turn lights on and off manually AND operate rule 17 manually by pressing Function button #4.



Zen Decoders are imagined, designed and manufactured by DCCconcepts Ltd  
 Our showroom and offices are located in Settle, North Yorkshire BD24 9RP, England **24**  
 Phone: +44 (0) 1729 821 080 \* sales@dccconcepts.com \* www.dccconcepts.com



**Unique features, real performance and exceptional installability**

**Specific Instructions: DITCH Lights.**

Ditch lights are progressively replacing all other forms of warning lights such as Mars lights and Gyalites. Ditch lights are usually mounted at about footplate height at either side of the loco front and rear ends. See image below. Common in the USA, Australia & other places, they are often also linked to the loco horn operation.

You will most often see them in action at road/rail crossing points, but they are also used for warnings at other times - e.g. when working in yards or loco depots. Research your chosen prototype for more details of ditch light use.

DITCH LIGHT SETTINGS	CV #	Default	Range	Comment and notes.
NOTE: All values are usually set to above Zero. This is because we need to simulate two lights that are usually turned on and steady when the loco is active - but will also flash when a function button (Pre-set to function 3) is pressed				
Ditch light flash TIMER	CV63	63	1~255	Sets how long Ditch lights will flash for when triggered. (Each 10 is equivalent to about 1 second)
Ditch light flash BLINK rate	CV117	3	1~255	Sets the flash frequency.

**About DITCH LIGHTS.**

Ditch lights are an effect that can add a lot of interest.

Ditch lights are additional to headlights. They are only ever active at the forward end of the loco.

They work as both an additional constant light and a warning light so they are generally turned ON all of the time that a loco is operating.

To activate the Ditch light flash, you will need 2 lighting wires and ideally 2 controller function buttons for operation, one to turn them on, plus one more to activate the flashing for a pre-set period on demand.

*Note: It will be useful if the DCC controller function button that you use to trigger the flashing is set to momentary operation rather than on-off.*

*Fortunately some DCC control systems (e.g. NCE) will already have the Whistle/horn button pre-set as a momentary function in parallel with F2. This is of course the perfect choice for a Ditch light ON button! If you use other brands, refer to your system manual for instructions on doing this)*

Setting up Ditch lights takes several steps, so we will give you a fully worked example for the set up of a diesel locomotive with ditch lights.



**Note:**

Ditch lights and “Rule 17” are both part of many prototypical lighting setups, so in the example on the next page, we are going to set up both, with our Ditch Lights set up so that they do not conflict with Rule 17.

Most modern locomotives are able to be used with either end forward, so we will add two ditch lights at each end of the locomotive. This means 3 powered light functions at each end of the locomotive for a total of 6.

This will be easy to do using our very versatile ZEN 218 6-function decoder.



## Unique features, real performance and exceptional installability

### Setting locomotive lighting up ready for both RULE 17 and DITCH LIGHT operation.

Rule 17 and Ditch lights are both required in a modern loco, so we show both in this example. Because we are setting up TWO light effects at the same time, we will present this setup process as two charts, followed by notes.

- \* You are also able to manually dim any light Functions set for rule 17 by using function button 4.
- \* The ditch lights are set to be directional so ONLY the ditch lights at the leading end will be on. They are also set to be turned on or off manually on or off via Function button 1. (F1 will turn them on in a steady state)
- \* Ditch light flashing is activated by use of the horn/whistle button which is a momentary function in parallel with the Function 2 button on some controllers. One press of this button will set the ditch lights flashing for the pre-set time entered into CV 63. If you don't have a horn/whistle button, use the Function 2 button to turn them on and off.

#### STEP 1: Decide which decoder function wires will connect to which light functions and activate them.

(The full chart for function mapping of decoder functions to function control buttons can be found on page 16)

Wire Colour	Used on this loco for	FN Map CV	Set to	Comment and notes
White Wire	Headlight end 1F0-F	CV33	1	FRONT headlight light - turned on by function button F0-F.
Yellow Wire	Headlight end 2 F0-R	CV34	2	REAR headlight light - turned on by function button F0-R.
Green Wire	Ditch light front Left	CV35	5	DITCH light pair #1 - turned on by function button F1. (These two will activate the front ditch lights)
Purple Wire	Ditch light front Right	CV36	5	
Brown Wire	Ditch light rear Left	CV39	6	DITCH light pair #2 - turned on by function button F1. (These two will activate the rear ditch lights)
Pink Wire	Ditch light rear Right	CV40	6	
<b>We also need to set CV61 to permit the "Dim when stopped" action of Rule 17</b>				
		CV61	17	Activation of dimming ability for Rule 17

#### STEP 2: Decide which lighting effects to enter into each wire colours "CVs for light effects & action" register.

In this case we are making all active functions semi-automatic and directional, but retaining manual control too.

- \* The full chart of wire-specific control CVs into which lighting effect direction value can be entered is found on page 18.
- \* The full chart of the lighting effects that are available / values to be entered to use them, can be found on page 19.

Wire Colour	Used on this loco for	Effect CV	Set to	Comment and notes
White Wire	Headlight end 1F0-F	CV49	8	Headlight at the front end. Directional. Rule 17 applied
Yellow Wire	Headlight end 2 F0-R	CV50	24	Headlight at the rear end. Directional. Rule 17 applied
Green Wire	Ditch light phase A FWD	CV51	10	Ditch light A at the front of the loco (On FWD only)
Purple Wire	Ditch light phase B FWD	CV52	11	Ditch light B at the front of the loco (On FWD only)
Brown Wire	Ditch light phase A REV	CV53	26	Ditch light A at the rear of the loco (On REV only)
Pink Wire	Ditch light phase B REV	CV54	27	Ditch light B at the rear of the loco (On REV only)

#### Operating the locomotive set up with both Ditch and Rule 17 lighting using the above settings

Function 0	Turns on headlights activates Rule 17. The headlight will automatically dim when the loco is stopped
Function 1	Turns on all 4 Ditch lights. ONLY the Ditch lights at the active front end of the loco illuminate.
Function 2	(Or Whistle/Horn button) Activates Ditch light flashing (for the pre-set period that you set in CV63)
Function 4	Manual control of headlight dimming (Manual rule 17 activation for use when switching, etc.)



Zen Decoders are imagined, designed and manufactured by DCCconcepts Ltd  
 Our showroom and offices are located in Settle, North Yorkshire BD24 9RP, England **26**  
 Phone: +44 (0) 1729 821 080 \* sales@dccconcepts.com \* www.dccconcepts.com

**Unique features, real performance and exceptional installability**

**CV64 sets the “Constant Dimming Level”: 1 to 20**

- *This is how bright lights will become when dimmed by the various lighting setup options.*
- *The overall range is 1~20. We have pre-set this to 4 as we assume that the loco will have LEDs.*

**General guide for settings:**

- *The lower the number, the lower the light level.*
- *LEDs will need low numbers, so we recommend that you set CV64 to between 1 and 6 for LEDs.*
- *Incandescent lamps (bulbs) need more energy always, so experiment between 8 and 15 for incandescent lamps.*

**Note please:**

Some experimentation will be necessary - We cannot be more specific, as LED and incandescent lamp brightness and efficiencies will vary quite a lot, depending on the age and brand of the locomotive you are using. (Incandescent bulbs are particularly variable)

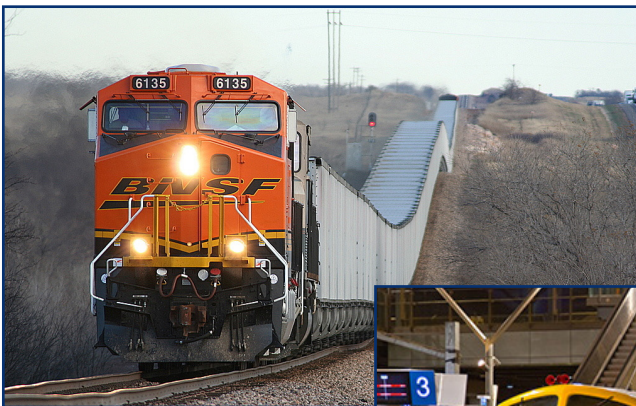



## Unique features, real performance and exceptional installability

Part 3: DCCconcepts BLACK decoders - Advanced SHUTTLE control, braking with ABC and Brake on DC. (Advanced ZEN Shuttle control, ABC braking and Advanced Brake on DC are ONLY available with ZEN BLACK)

### Zen BLACK ABC Braking abilities:

Having read many reviews of ABC braking performance in decoders made by several popular brands, it was clear to us that some worked well, but overall, there was little or no consistency in the way that they performed, and that with only ONE way to trim slowing or stopping speeds in each brand, results were often less than ideal.

It was also clear that while basic ABC implementation by the user was easy to do and relatively low cost, a little more thought needed to be put into the triggering and activation of ABC, so that it was not necessary to think about "Left and Right rail", to cut more than one rail at any time OR to re-wire an ABC trigger device if it was inadvertently installed backwards....

Most importantly, ABC seemed to be a limited functionality option - and ANY extended ABC use in other brands always seemed to require an expensive add-on device (This was certainly the case with the three "better brands" that we evaluated).

We just could not see why that should be necessary at all!

Finally, we do not like just following along and so yet again, we wanted to add something new. Our objectives were.

- Very simple set-up of ABC.
- Versatile adjustment of ABC with both slow down and stop, intermediate running speed and acceleration rates/distances.
- Implementation of adjustable slow down and stopping sections for automation of terminal station stopping, automatic storage and fiddle yards or even simple and direct signalling integration via ABC for those who wanted it.
- Low cost ABC board with switchable orientation (via easy to use headers).
- Both on-board or external triggering of the ABC board for "ABC section on or off".
- Fully Automated ABC triggered shuttle abilities, all totally within the Zen Black decoder.
- A choice of simple timer adjustment or external triggering for shuttle-related station stops, within the decoder.
- Addition of "multiple, easily set up station or passing loop stops", all totally within the Zen Black decoder.
- Ability to use ABC boards interactively so that "Automated Shuttle Trains" can also share main line use.

We let our imagination loose on this one so **Zen BLACK** and its ABC possibilities were an enjoyable development.

Our ABC implementation in the decoder now does exactly what we wanted, and for those who want to really fine tune it, it has variety of ways to control ABC slow down, stop, then accelerate back to running speed.

The ABC board switching needed total reliability long term so we used moveable headers for durability & reliability - Our ABC boards can also be controlled manually or with external switching from Cobalt motors or any device with reliable switches.

We are especially proud of our fully internal unique self-contained automated DCC-shuttle ability. You can have a simple end-to-end shuttle with adjustable stopping time, or choose to pre-set the number of station or other stops that your train will make - all with simple CV changes that can even be adjusted while the train is running.

All you will need is a Zen Black decoder and a low cost ABC control board to control each action. There is NO need for any external controller or computer interfacing at all. Of course, it works perfectly with all DCC-compliant / compatible controllers.

We did not forget to look at "Brake on DC" abilities with **Zen BLACK** either....

Our Zen Black software even contains a simplified "Brake on DC ability" that makes this legacy approach to braking much easier to implement. It works with only ONE rail cut, and does not need any complex rectification or secondary switching. Using our new approach and the simple BODC board we have created, locos with a Zen Black decoder set to "Brake on DC" now transit section boundaries smoothly and respond only to a correctly oriented rectification.

This makes Zen "Brake on DC" an excellent choice for single track, bi-directional main lines if you do not want to use ABC.



Zen Decoders are imagined, designed and manufactured by DCCconcepts Ltd  
Our showroom and offices are located in Settle, North Yorkshire BD24 9RP, England **28**  
Phone: +44 (0) 1729 821 080 \* [sales@dccconcepts.com](mailto:sales@dccconcepts.com) \* [www.dccconcepts.com](http://www.dccconcepts.com)

**Unique features, real performance and exceptional installability**

Part 3 of this manual is all about ABC control, ABC shuttle and Brake on DC. Simple settings need only CV detail and more complex things benefit from an example (as we prepared for lighting functions) so we will take the same approach here.

**Please note:**

- ABC braking and Advanced “Brake on DC” (BODC) are available only in **Zen** BLACK Decoders.
- The classic “Brake on DC” ability is however available in both Zen Blue and Zen Blue+ decoders.

**ABC control boards, Brake on DC control boards.**

- We will show and explain the use and connection of these later in this document.
- We will also show them in place in several clear examples.

**ABC control CVs and their adjustment.**

- CV27 is the primary decoder instruction CV for ABC and Advanced Brake on DC activation. Setting just CV27 will activate ABC with the ability to stop and slow down PLUS, our ABC shuttle. Just setting CV27 appropriately plus a simple change in CV29 to disable DC running will fully activate Brake on DC with all standard default settings.
- We have listed all other ABC or BODC related CVs here. We will cover them individually AND as examples with diagrams.

**CV27 Primary control CV for ABC and advanced BODC Default =0 (inactive) Variables/options = See Chart**

**An ABC primer - Some simple real-world test track ideas to show you how ABC will work for you.**

- Create an isolated section in your test track. It should be long enough for the loco to slow down and stop plus 1 loco length.
- Install an ABC control module to that section and turn it on (see the simple ABC diagram below)).
- Install your Zen Black decoder. Set CV3 and CV4 to give your loco a nice smooth acceleration and deceleration.
- Now, using either Program on the Main OR on the dedicated program track, set CV 27 to 1, 2 or 3 (page 30 has details).
- Run the loco into the ABC section - the train should either slow down smoothly OR come to a smooth, steady stop.
- Turn the ABC control module off, and the loco will now return to normal running speed.
- Change the two BLUE headers on the ABC board from ABC 1 to ABC 2.
- Run the loco into the ABC section - If it slowed in the first test, it will stop this time. If it stopped last time, this time it will slow.
- And... if you have 2x ABC boards - you can use the end of the test track for #2. Set one ABC board to slow, the other to stop. (p32)

**THE ABC “TEST TRACK”**

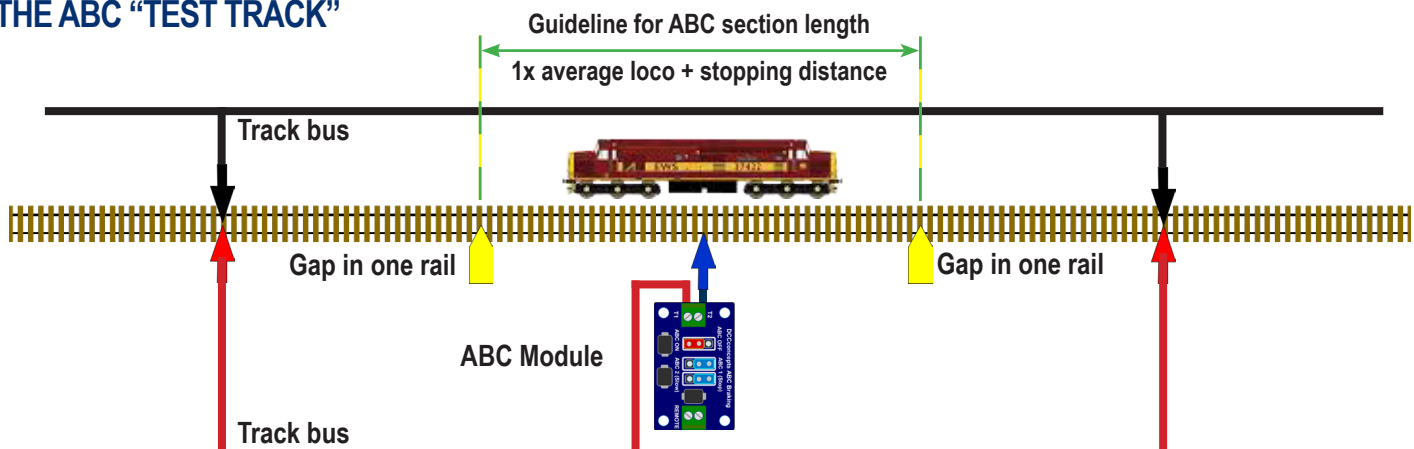

Now you have seen ABC in action, lets look deeper into its abilities - exploring and learning about the CVs that control ABC operations and fine-tune how ABC works... and their many useful options.



## Unique features, real performance and exceptional installability

Now we have looked at the basics, lets look at the other CVs that you can use to modify or fine-tune loco stopping distances or initiate other actions. First we will cover ABC braking, then Advanced Brake on DC.

We will follow this with some examples that include everything from creating the gaps to installing and switching the control boards to the track and tuning the way your loco will act when it meets an active section... making you an expert in no time!

CV27=	Expected "ZEN Advanced ABC" action if CV is set to that value	Related CVs
0	<b>ABC control and advanced "Brake on DC" (BODC) will both be inactive / off</b>	Nil
1	<p>ABC is active. A loco running in FORWARD will stop in an activated ABC section that is set to ABC-1 on our ABC module (more++) and will slow down in an active ABC section that is set to ABC-2 on our ABC module (more - -) to the ABC rail.</p> <p>The loco will NOT stop if it is running in the REVERSE direction.</p> <p><i>The loco can still be controlled after stopping. To do this, just change loco direction to REV and use the DCC controller to manually drive it out of the active ABC slow or stop sections. Alternatively, turn the ABC control module off by shorting the Remote terminals.</i></p>	Also see CVs 55, 56, 58.
2	<p>ABC is active. A loco running in REVERSE will stop in an activated ABC section that is set to ABC-1 on our ABC module (more++) and will slow down in an active ABC section that is set to ABC-2 on our ABC module (more - -) to the ABC rail.</p> <p>The loco will NOT stop if it is running in the FORWARD direction.</p> <p><i>The loco can still be controlled after stopping. To do this, just change loco direction to FWD and use the DCC controller to manually drive it out of the active ABC slow or stop sections. Alternatively, turn the ABC control module off by shorting the Remote terminals.</i></p>	Also see CVs 55, 56, 58.
3	<p>ABC is active. The loco will STOP at any active ABC Stopping section that is set to ABC-1 on our ABC module (more++) in BOTH the FORWARD and REVERSE directions. The loco will slow down in any active ABC section that is set to ABC-2 on our ABC module (more - -) to the ABC Rail in BOTH the FORWARD and REVERSE directions.</p> <p>This CV setting is primarily for bi-directional single line working.</p> <p><i>The loco can still be controlled after stopping. To do this, use your DCC controller to change the loco direction. For example, if the loco entered in FWD, change to REV. If it entered the section in REV, change to FWD. You can now back out of the ABC section. Alternatively, just turn the ABC control module off.</i></p>	Also see CVs 55, 56, 57, 58.
4	<p>ZEN Automatic train shuttle with variable timing and unlimited automatic station stops. The ABC board will be more ++ for shuttle ends and more - - for the interim station stops.</p> <p><i>The stop timer CVs are CV59 and CV60. When stopped at any position, the train will wait for the timer settings but can still be manually controlled by either (1) reversing direction and taking over control by using the DCC controller (2) turning the ABC control modules off.</i></p> <p>There are several other options for Shuttle Control. See the Related CVs column at right.</p>	Also see CVs 55, 56, 58, 59, 60
8	ABC activation via a signal control decoder (adjust with CV62 for sensitivity)	
CV27=	Expected ZEN Advanced Brake on DC action if CV is set to that value	Related CVs
16	Advanced Brake on DC. Stop if BODC on, right rail more (+) , left more (-)	DC Running off (CV29)
32	Advanced Brake on DC. Stop if BODC on, right rail more (-) , left more (+)	DC Running off (CV29)
48	Advanced Brake on DC. Stop in either direction if the BODC unit is ON	DC Running off (CV29)



**Unique features, real performance and exceptional installability**

**CV3 CV3 Acceleration is the default reference for ABC / BODC Default = 12 Range = 1~255**

CV3 is the default acceleration and is active with ABC, etc. Use CV3 to adjust the way that your locomotive moves off when it leaves an ABC section. Left at its default it will give smooth results, but we do encourage experimentation.

**CV4 CV4 Deceleration is the default reference for ABC / BODC Default = 12 Range = 1~255**

CV4 is the default / simplest way to adjust ABC related deceleration. Use CV4 to adjust the way that your locomotive slows down or slows and stops when it enters an active ABC section. Left at its default it will give smooth results, but we do like to encourage experimentation. CVs 55, 57 and 58 adjustments are also available (see specific notes relating to their use).

CV55=	Expected "ZEN Advanced ABC" action if CV is set to that value	Related ABC CVs
CV55 settings will apply whether main ABC control CV27 is set to 1, 2 3 or 4		
0	<p>DECELERATE AT SAME CV4 RATE AS NORMAL LOCO DRIVING.</p> <p>If CV55 is left at 0 (Zero) an ABC control module will stop or slow the loco depending on the orientation of the ABC module relative to the ABC rail.</p> <ul style="list-style-type: none"> <li>• Stop effect: ABC will stop the loco at the deceleration rate set into CV4.</li> <li>• Slow effect: ABC will slow the loco to 50% of its entry speed. It will slow down at the deceleration rate set into CV4.</li> </ul> <p>Example: If a loco enters an ABC section at Speed Step 60 it will slow down to SS30). Once the loco is released from ABC, acceleration will be as per your CV3 settings.</p>	<p>CV27, CV4 (+CV48 if your locos will move directly from SLOW to STOP sections at any time)</p>
1	<p>A SPECIAL DECELERATION RATE FOR ABC ONLY.</p> <p>If CV55 is set to 1 an ABC control module will stop or slow the loco depending on the orientation of the ABC module relative to the ABC rail.</p> <ul style="list-style-type: none"> <li>• However, the ABC-related deceleration rate will change to act at the rate that you have now pre-set into CV58. This rate will apply ONLY when in an ABC controlled section, so you can have <u>both</u> a normal deceleration rate <u>and</u> an "ABC only" deceleration rate.</li> </ul> <p>Note: If you set CV55 to 1, then CV58 also needs to be set to a value above zero).</p>	<p>CV27, CV58 (+CV48 if your locos will move directly from SLOW to STOP sections at any time)</p>
2	<p>SLOW DOWN TO A SPECIFIC SPEED STEP.</p> <p>If CV55 is set to 2, an active ABC module will stop or slow the locomotive depending on its orientation. STOP and SLOW deceleration rates will remain as per your settings in CV4.</p> <ul style="list-style-type: none"> <li>• However - the ABC-Slow action will now slow the loco <b>to a specific speed step</b>.</li> </ul> <p>This needs a setting in CV57. The range is 1~128 representing individual speed steps. (Example: if you set CV57 to 15, no matter what speed step the loco is on as it enters the ABC section, it will slow down to SS 15)</p>	<p>CV27, CV57 (+CV48 if your locos will move directly from SLOW to STOP sections at any time)</p>
3	<p>BOTH SPECIAL DECELERATION RATE AND SPECIFIC SPEED STEP.</p> <ul style="list-style-type: none"> <li>• Setting CV55 to 3 will COMBINE 1 and 2 above, giving you use of BOTH the special deceleration rate set into CV58 <u>and</u> the ability to slow down to a specific speed step.</li> </ul>	<p>CV27, CV57, CV58, 48</p>

**CV48 Adjustment if a Loco moves directly from ABC SLOW to ABC STOP Section Default = 15 Range = 1~255**

When a locomotive moves directly from an ABC SLOW DOWN section to an ABC STOP section, there will be a short period where the locomotive is in both sections. This may cause the loco to accelerate slightly (It will vary by length of locomotive).

To prevent this, we have added a "Time delay when leaving ABC SLOW option" using CV48. You can adjust it in 255 steps. Each step is equal to 0.1 seconds The default is set at CV48 = 15 or 1.5 seconds. Adjust it individually to suit each of your locomotives.



Zen Decoders are imagined, designed and manufactured by DCCconcepts Ltd  
 Our showroom and offices are located in Settle, North Yorkshire BD24 9RP, England **31**  
 Phone: +44 (0) 1729 821 080 \* sales@dccconcepts.com \* www.dccconcepts.com



thinking outside the square  
concepts

**Unique features, real performance and exceptional installability**

CV56=	Additional conditions for ZEN ABC & ABC-SHUTTLE operation	Related CVs
CV56 relates to shuttle stopping time or actions relating to general ABC stopping if CV27 is set to 1, 2, 3 or 4.		
0	<p>CV56 = 0. Timer-controlled intermediate station stops for Zen Shuttle operations.</p> <ul style="list-style-type: none"> <li>If CV27 is set to 4 (For ZEN Shuttle operation) and CV56 is left its default of zero, intermediate station stop timing is controlled by the value that you enter into CV 60.</li> </ul> <p>Note - you can also release a loco from an intermediate stop by turning off the ABC module at which the train stopped. (Perhaps by linking to a turnout controlled switch).</p>	CV27, CV4, CV3 CV58
1	<p>CV56 = 1: Interactive control of intermediate station stops for Zen Shuttle operations.</p> <ul style="list-style-type: none"> <li>If CV27 is set to 4 and CV56 is set to 1 the Shuttle end stops will remain timer controlled, but any intermediate station stops will now be controlled <u>ONLY</u> by turning the ABC module ON or OFF. (Stop times that you have set in CV60 will NOT be active)</li> </ul> <p>This is a very useful way to arrange semi-automatic ZEN Shuttle operations - using this mode, you can have a shuttle train that also uses the main line, diverting shuttle trains into loops as needed. If the loop turnout is in turn linked to the ABC control module, the loco / shuttle train will be held there until you release it.</p>	CV27, CV4, CV3 CV58
2	<p>CV56 = 2: Terminal or Storage yard mode "Stop and set speed to ZERO".</p> <ul style="list-style-type: none"> <li>If CV27 is set to 1 or 2 and CV56 is set to 2 - When the loco stops at any ABC stop section, the locomotive decoder will automatically set its speed to ZERO.</li> </ul> <p>This is an ideal approach for automatically controlled, hidden storage yards and terminal type passenger stations. When the loco gets to an ABC controlled stop section, it will stop and then set its speed to zero. The loco will remain ready for you to either hit reverse and drive it out of the siding, or turn the ABC module off &amp; drive it out if the yard is loop-based.</p>	CV27, CV4, CV3 CV58

**CV57 Set this CV to SLOW the locomotive to a SPECIFIC SPEED STEP Default = 12 Range is 1 to 64**

CV57 changes the way that the loco will react to a slow down ABC controller

**CV57 will NOT be active unless CV55 is also set to 3.**

If CV55 is NOT set to 3, the loco will keep slowing down to 50% of the ABC slow-section entry speed step level. However if CV55 is set to 3 AND CV57 is set at any level between 1 and 64 then that is the speed step that the loco will slow down to. CV57 default is set to 12.

- Because the slowing of the loco is so consistent with this approach, it is ideal where an ABC slow section is directly followed by an ABC stop section. This is because having the ability to always approach an ABC stop section at exactly the same speed step will greatly improve the accuracy and consistency of loco stopping distances, making any loco-by-loco fine tuning much easier.
- This highly accurate "Approach slow then stop" ability is of course perfect for passing loop, terminal station and storage or fiddle yard automation - and, of course, it is really effective for restricted speed or signalled areas that need accurate control.

**Use this CV sensibly. Always set it to a level that will be below the usual "approach speed" for the ABC controlled slow-down section. If you set it to a speed step that will be above the approach speed, then the loco will speed up!**

If the loco will move directly from an ABC SLOW section to an ABC STOP section, then leave CV3 at 12~15 or set CV48 so that is delays any acceleration until after the loco's full wheelbase has passed the "Slow to stop" transition. (See full CV48 detail on page 31)



Zen Decoders are imagined, designed and manufactured by DCCconcepts Ltd  
Our showroom and offices are located in Settle, North Yorkshire BD24 9RP, England **32**  
Phone: +44 (0) 1729 821 080 \* sales@dccconcepts.com \* www.dccconcepts.com





**Unique features, real performance and exceptional installability**

**CV58** Set this CV to have ABC sections with a different deceleration to the rate that you have set into CV4 for normal locomotive driving. **Default = 0** **Active range is 1 to 255**

If left at the default of Zero (0) - the locomotive will continue to use the standard CV4 deceleration rate.

However if CV58 is set at any level between 1 and 255, the loco will use that deceleration rate when in an active ABC section.

- Experiment, but remember that very high values will mean very slow deceleration.
- For the most effective and realistic results, planning for ABC use should consider both the length of the ABC sections and use of the various deceleration rate options before the rails are cut and the ABC modules are installed.

### AUTOMATIC SHUTTLE STOP TIMER CVs

**CV59** CV 59 sets the wait time AT EACH END of an automated or semi-automatic shuttle train. (CV60 sets the intermediate stop times) **Default = 5** **Active range is 1 to 255**  
(1 = 10 seconds) (10 seconds to 42 minutes)

Enabling an automated shuttle train with Zen Black is very simple. Once you have set CV27 to 4 and installed an ABC module at each end of the shuttle route, it is basically ready to go. CV59 lets you adjust the wait time at each end to anything that you want it to be.

**CV60** CV 60 sets wait time at any intermediate stop in an automated or semi-automatic shuttle train. (CV59 sets "end station" stop time) **Default = 5** **Active range is 1 to 255**  
(1 = 10 seconds) (10 seconds to 42 minutes)

Adding intermediate station stops or even creating a semi-automatic shuttle where the shuttle train can be stopped and held in loops to allow main line trains to pass is simple (with the loops ABC boards controlled via Cobalt point motor switching).

- You can have as many intermediate stops as you want with NO NEED TO CHANGE CVs.
- Just set up the intermediate ABC modules with their direction headers set opposite to those on the Shuttle-end modules.
- In "Shuttle mode", if the intermediate station stop ABC modules are ON - then the loco will stop and wait until the pre-set time expires or earlier if you decide to turn the ABC module off.

ABC module switching can be done with the on-board switch headers, with an external switch, or with switches linked to detectors or any Cobalt point motors that control the ABC activated track the loco is on. Combinations of timing and ABC switching will give many options.

**DCCconcepts Advanced Brake on DC activation** **Default = off** \* Set DC running OFF in CV29  
\* Set CV27 to 16, 32 or 48

Traditional "Brake on DC" has existed for a long time - However it has rarely been used because it requires an awkward approach to wiring. Both rails needed to be isolated and the section had to be rectified after the entire loco was in the section to prevent problems. That involved either manual control or at least one detector to do the switching at the appropriate time.

We looked at this at the same time as we worked on ABC. We found that a small change made "Brake on DC" much easier.

**Our changes have made a significant difference to wiring the layout for Brake on DC.**

- DCCconcepts "Advanced Brake on DC" needs only ONE rail to be gapped.
- The Brake on DC section can be left on while the loco enters the section, unlike normal Brake on DC control.
- The rectification needed is simple with very simple connections. (Our low cost DCD-BDC Brake on DC control board is also switchable to let you reverse it or turn it on and off, directly from the headers OR via any form of external switch)

**Activation and set-up remains very simple, with only TWO CVs to change.**

- Change CV29 to turn off DC running (Reduce CV29 setting by 4... e.g. If CV29 = 6, make it 2, if its 36, make it 32).
- Change CV27 to engage the Brake on DC action you need (Set CV27 to 16, 32 or 48).

**NOTE: ABC Braking & Brake on DC cannot be activated at the same time. Only DCCconcepts ZEN has Advanced Brake on DC.**

**SEE the BRAKE on DC CONNECTION DIAGRAM ON PAGE 48**



Zen Decoders are imagined, designed and manufactured by DCCconcepts Ltd  
Our showroom and offices are located in Settle, North Yorkshire BD24 9RP, England **33**  
Phone: +44 (0) 1729 821 080 \* sales@dccconcepts.com \* www.dccconcepts.com



**Unique features, real performance and exceptional installability**

### ABC and Brake on DC examples: The symbols we have used in our drawings

Now we have given you an overview of **Zen** BLACK and its ABC control CVs, we will take a look at some real-world examples, covering wiring, connecting and using DCCconcepts ABC control boards and, of course, the CV settings needed.

Please note: We have shown only the rail breaks and wire connections that relate solely to ABC. Of course, there will be other rail breaks for turnout frogs and other track feeds needed for train power.

A break in ONE rail is yellow looks like this:  A break in BOTH rails looks like this: 

Track connections look like this:  Blue is for ABC, Red is rail 1 and Black is rail 2: 

And... an ABC braking module looks like this:  Look for the ABC module orientation in each example.

### DCCconcepts advanced ABC and Brake on DC: the DCCconcepts control modules

#### ABC and Advanced Brake on DC control modules & their connection.

**ABC:** A basic ABC control circuit is actually relatively simple. 5 x high speed 3 amp diodes modify the DCC signal at track power level, making it asymmetrical.

*This is the schematic. If you want to make your own, you can, but use only 3-amp high speed diodes. Create and connect them carefully please. Mistakes will cause train and layout running problems.. Or damage.*

**BODC:** DCCconcepts Advanced brake on DC is simpler than standard brake on DC. However, as it needs to form a more complicated series-parallel arrangement with the section of track that it controls, we do not show it here.

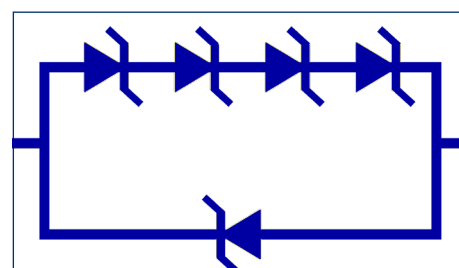

#### DCCconcepts control modules.

##### For Advanced ABC control

- DCD-ABC.3 - Pack of 3 ABC modules
- DCD-ABC.6 - Pack of 6 ABC modules

##### For Advanced BODC control

- DCD-BDC.3 - Pack of 3 Brake on DC modules
- DCD-BDC.6 - Pack of 6 Brake on DC modules

#### DCCconcepts switchable ABC and Advanced Brake on DC modules.

You may want to turn ABC on and off at times, and the orientation of the modules is very important for correct operation of both ABC and Brake on DC, so a much easier approach to getting up and running is to use our DCCconcepts ready-to-use modules.

These low cost, easy to use modules make it simple for you to use our unique new features. They have screw terminals for connection, so no soldering is needed, and we have built in some useful switching, meaning that you will never have to disconnect anything to turn them on or off... Or to adjust how they work for you.

- Low cost and available in packs of either three or six modules.
- Solder-free SCREW terminals for connection.
- Small size for convenient installation almost anywhere.
- ABC / BODC on-off via on-board or remote control via Cobalt motors, etc.
- Reverse the ABC Module orientation with a simple switch (Via Headers).

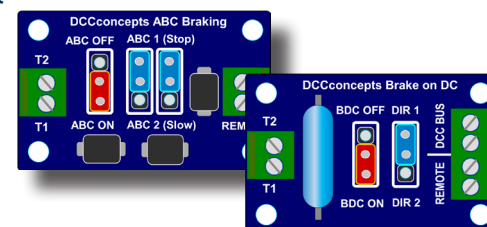

*These images are actual size.*

### USING SLOW AND STOP SECTIONS ADJACENT TO EACH OTHER:

If an ABC SLOW section is directly followed by a STOP section, there will be a loco-length transition as the loco moves from the slow section to the stop section and the locomotive may seem to speed up slightly. To adjust for this, either adjust CV48 to introduce an "Acceleration delay" or just increase the CV3 Acceleration setting to a higher number (default for CV 3 is 12, try 12~16).



Zen Decoders are imagined, designed and manufactured by DCCconcepts Ltd  
 Our showroom and offices are located in Settle, North Yorkshire BD24 9RP, England **34**  
 Phone: +44 (0) 1729 821 080 \* sales@dccconcepts.com \* www.dccconcepts.com

**Unique features, real performance and exceptional installability**

DCCconcepts ABC examples and usage will be covered in pages 34 to 47. An Advanced Brake on DC example is on p 48.

**The DCD-ABC control module:** Connecting the DCD-ABC control module and using the onboard header switches.

**Wiring the DCD-ABC module - Connections.**

- Connect terminal T1 to the section of rail that you have isolated to become an ABC control section.
- Connect terminal T2 to the track power bus wiring on the same side as the ABC section rail gap.

**Operating the DCD-ABC module - The header switches.**

- To turn the ABC section off / turn ABC activity, use the RED header.
- To reverse diode orientation and invert the signal to change the ABC module from STOP loco to SLOW loco, move both the BLUE headers downwards.
- If you want to use an external switch to turn the ABC module on or off, connect it to the two REMOTE terminals (Turn it on to turn ABC off, off for ABC on).
- For automatic control, connect a Cobalt turnout motor switch or similar to the REMOTE terminals. As above, set so that closed contacts will turn ABC off)

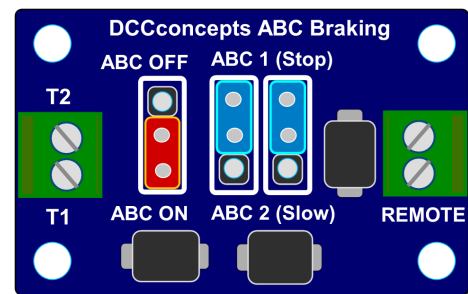

**Example #1: Basic ABC use and connection, ABC stopping using one DCD-ABC module.**

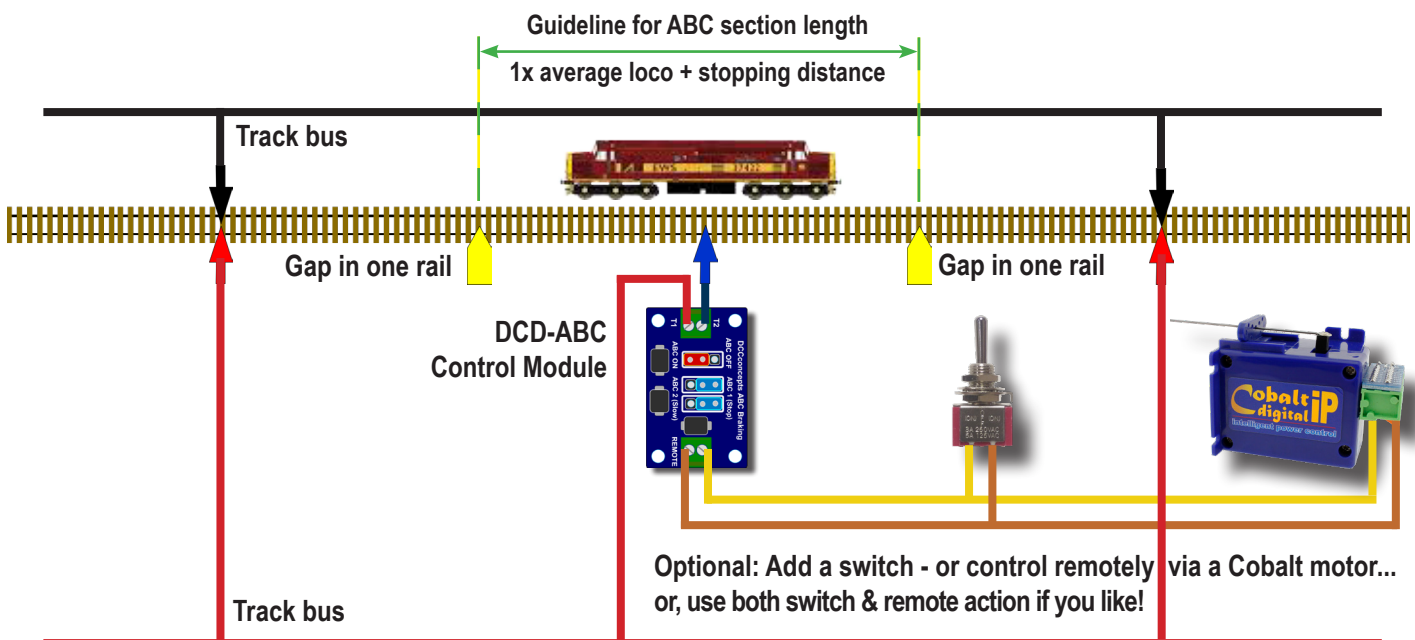

**Learning about ABC - SETUP and CV changes to activate Advanced ABC for a single section**

- Cut one rail, making the ABC stop section as long as 1 loco plus your preferred / planned braking distance (as above).
- Connect wiring and the DCD-ABC board to the test track as per this diagram.
- Set CV27 to 1 or 2 for now. This allows the loco to react in one direction, but it will ignore the ABC modules in the other (this would be the typical set-up for double track operation).
- Experiment with moving both the BLUE Headers to reverse the asymmetric ABC signal.
- Adjust CV55, 56, 57 or 58 to see what may happen.

**and remember....**

- If you get lost, confused or stuck, don't worry. Just set CV 8 to 8 to reset the decoder to default settings and start again.

**Unique features, real performance and exceptional installability**

**Example #2:** Basic ABC use and connection. One ABC slow down section plus one ABC stop section.

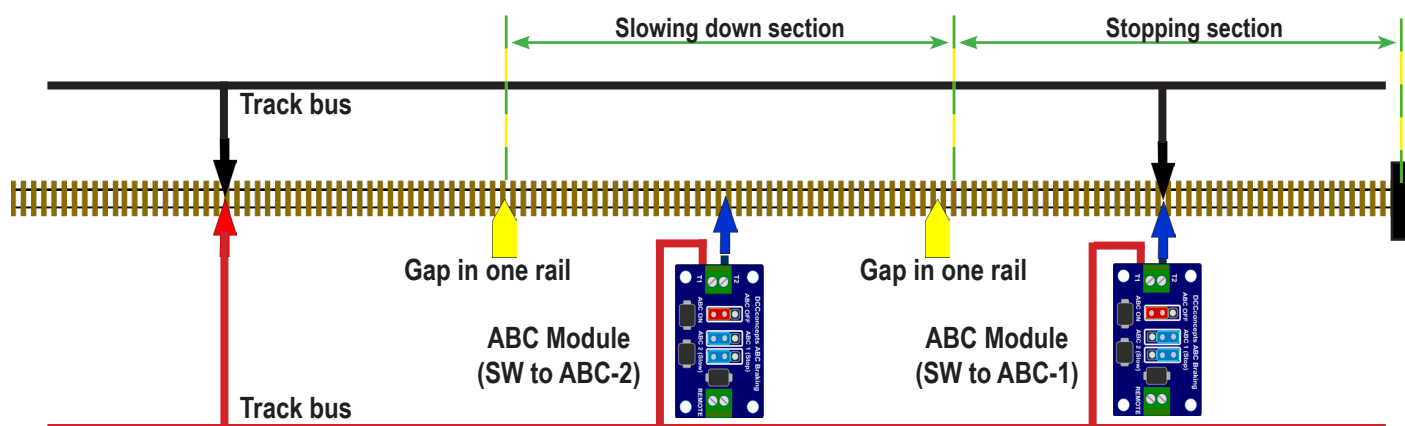

**SET-UP and CV changes to activate Advanced ABC for both slowing down and braking.**

- Set CV27 to 1 for now. This stops the loco if the headers on the ABC module are set to ABC-1, slows it if they are set to ABC-2.
- Plan for TWO sections, at the end of the test track: each should be at least one loco length + stopping distance.
- Cut the ABC rail, making both the ABC Slow section and the ABC Stop section the planned length (red side in diagram)
- Connect the wiring and the DCD-ABC modules to the test track as per the diagram.
- Set the SLOW section ABC module to ABC-2 and the STOP section ABC module to ABC-1.
- Experiment with changing the headers on each module from ABC-1 to ABC-2 to reverse the asymmetric ABC signal.
- Once the loco stops, you will be able to leave the ABC section by reversing the controller direction and driving out. Because you are now driving the loco against the ABC direction as you reverse out, the SLOW section will be ignored.
- Adjust CV55, 56, 57 or 58 to see what may happen and learn about things like adjusting stopping distance.
- If the loco briefly accelerates between SLOW and STOP, adjust CV48 settings or change CV3 Acceleration to about CV3 = 14

**Before we move on to other examples, please remember:**

- *If you get lost, confused or stuck, don't worry. Just set CV 8 to 8 to reset the decoder to default settings and start again.*

**If you would like some more specific help, or if you have questions, please feel free ask. You can either:**

- Telephone us on +44 (0) 1729 821 080
- Email us at [salesuk@dccconcepts.com](mailto:salesuk@dccconcepts.com)
- Join our modelling & advice forum at [www.dccconceptsforum.com](http://www.dccconceptsforum.com). (also available as a direct link from our website).
- Visit us and learn directly from our own staff.

**Note:**

- We are open 7 days every week and we look forward to seeing or hearing from you 10am to 5pm UK time (summer) and 10am to 4pm (Nov to Feb). Appointments are NOT needed.
- Of course, not everyone works every day, so if you are coming a long way with specific questions to ask, it may be worth checking that our more specialised tech staff are at work that day - just give us a call and we will make sure for you.
- We will always welcome you with a smile and a cup of tea or coffee when you visit.
- We are located directly behind Settle Station... Less than 30 metres from the platforms.
- If you come by car, we have customer parking available right outside the door!

**Example #3:** DCCconcepts ABC: Train stop - reliable automatic stopping at a terminus, storage or fiddle yard

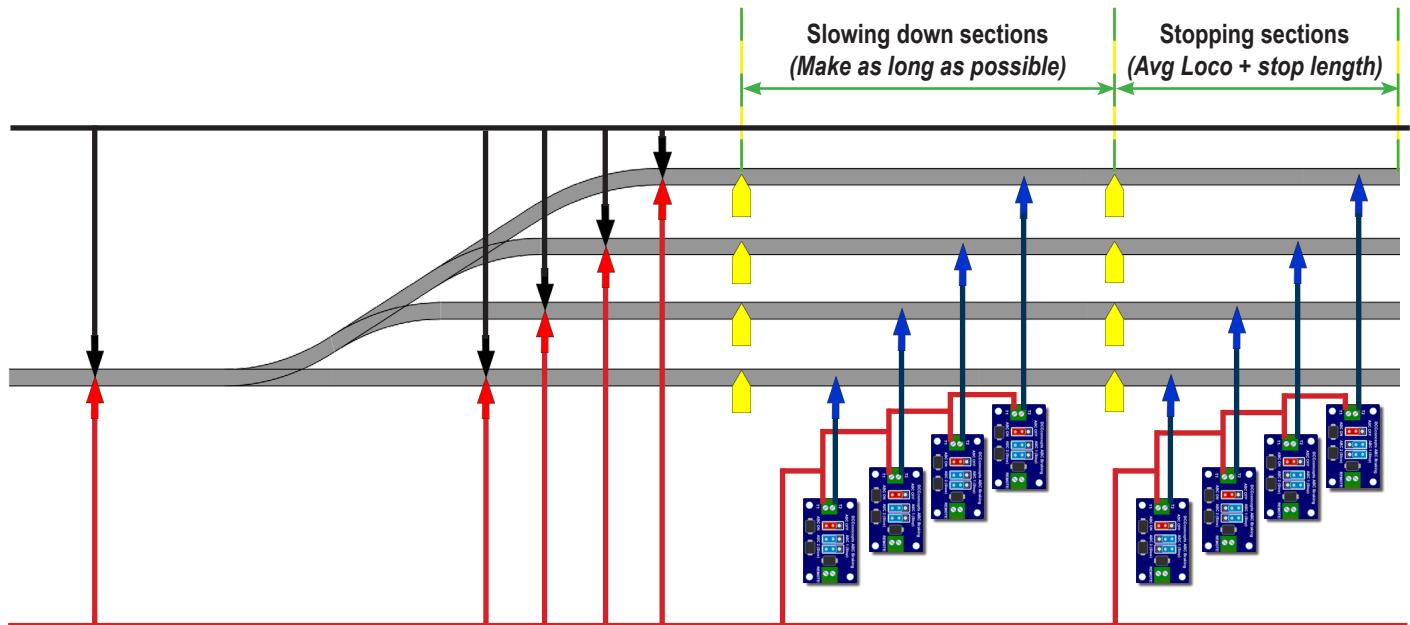

**This looks complicated, but it is really the same as our ABC Example 2, but repeated several times.**

This is a simple way to set up semi-automatic control of train arrivals at a terminus or storage yard. You will never need to turn the ABC modules off as you can always take control of any loco just by changing direction once it has stopped. You can then just back it out of the ABC sections under full manual control.

- Change CV27 to 1, 2 or 3 depending on your general ABC use (they will all work in this situation).
- Tune deceleration and stop distances. Refer to CV4, CV55, CV57, CV58.
- In this sort of arrangement, we suggest that you utilise CV55 = 2 or 3 and then set CV57 to specify the speed step so that your locos always slow to the same speed step before they meet the ABC stop section. A consistent arrival speed will make it much easier to tune each locomotive's deceleration & stop position.
- Once set up, just drive a loco or train into the sidings and it will slow down as it approaches, automatically stopping at the end.
- If you are careful with the set up of each loco, you will get remarkably consistent stopping distances as each loco will always enter the STOP section at exactly the same speed step.
- Once it has stopped, you can take control again by reversing direction. The loco will start to accelerate back to the same speed setting that it entered the STOP section. You can easily control the speed interactively of course.
- If you want the loco to sit and wait for you to start to drive it out after you have swapped its direction, then set CV56 to 2. Once this has been set, the loco will stop and automatically re-set its speed to 0 (Zero).

**Things that you might like to experiment with.**

- CV27 directional control of ABC operation (CV27=1, 2, 3).
- You may need to adjust CV48 if locos speed up when transiting from ABC slow sections to ABC stop sections
- Changing the switches (headers) on the ABC modules to see what happens (and connecting via a point motor switch).
- Deceleration adjustment options when in an ABC section, using combinations of CV4, CV55, CV57 and CV58.
- Adjusting different locos or trains (big, small, long, short) so they all stop in identical positions.

**Unique features, real performance and exceptional installability**

**Example #4: Bay platform control and automatic stop at a platform. (Also applicable to passing loops)**

To help us to keep the diagram clear, we will show both a Slow and Stop module for the stub-end platform siding, but only a stop module for the loop-related stops. This is only one possibility - you could make this formation with both Slow and Stop ABC modules in all areas, or, of course, create it with only Stop sections in all areas if you wish. A third possibility is one Slow down section at each end of the station area, with Stop modules at each platform.

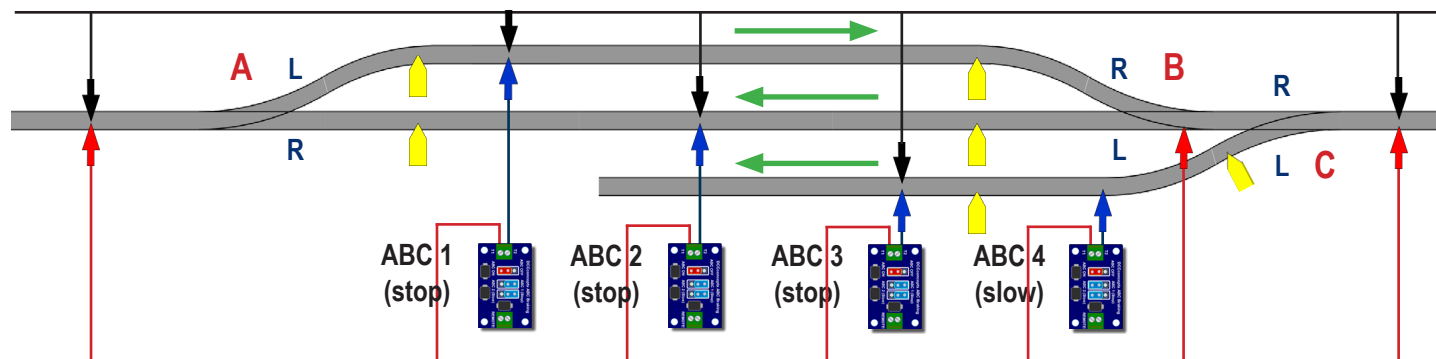

**Let's look at this example one area at a time. If we do that, then it will be easier to understand.**

**Overview:**

- General wiring is as per normal DCC practice. Point-work is assumed to be live frog (Electro frog)
- Gaps are created for one module in the loop, one in the main line and TWO modules in the "Bay Siding".
- ABC1 and ABC 2 will need to be set. Connect an SPST on-off switch to the two "REMOTE" terminals. (See image p33)
- CV48 may need adjusting to make sure transition from ABC slow to ABC stop is smooth

**Creating semi-automatic interlocking and ABC controlled station stops with DCCconcepts ABC modules.**

- To this in an easy to understand way, we will assume constant platform allocation depending on train direction.
- In this case we will set it up for the upper platform to be accessed from right to left, the central platform from left to right and the bay platform siding from right to left (the green arrows in the diagram above).
- Its nice to have both automatic and manual control sometimes, and this is not a problem. The modules can, if needed, be turned off and on manually with an external switch. The switch can just be wired to the "Remote" terminals of the ABC modules in parallel to the turnout motor switching if you choose to add it.

**Linking ABC module control to turnout position.**

- Now we know how trains will approach each platform, the linking of ABC modules to the turnout position is easier.
- We will link the switches on each motor so that they "interlock" with the ABC control modules automatically.
- We have added connection diagrams covering connection to Cobalt switching on page 39. (If you use other point motor brands, the principals will remain the same but you will need to interpret the wiring accordingly)

**Turnout A and B relative to ABC modules 1 and 2.**

- We will set up turnout switching the loops and bay siding so that all of the turnouts are independently switched.
- We will connect the "Remote" terminals of ABC 1 and ABC 2 to the SPDT switches on the Cobalt turnout motors that control turnouts A, B and C. (To make it easier, the two modules in the bay platform will not need switching at all).

**The logic will now be as follows.**

- When turnout A is set for the upper loop, but turnout B and C are not, the ABC automated station stop in the loop is active.
- When turnout B and C are set for the main, but turnout A is not, the ABC automated station stop for the main is active.
- When turnouts A, B and C align for a clear through route, via either the loop or main, the train will not be stopped on that route.

**Unique features, real performance and exceptional installability**

**Example #4 continued:** Connection for turnout motor switches and DCD-ABC module via remote terminals

- Turnout motors A and B control the loop, but the line is not actually ever clear unless C has also been set to the main.
- Therefore C acts as an added safety interlock and will not allow the ABC modules to turn on unless it is also properly set.
- To do this, we wire the connections to the ABC board "Remote" terminals via the switches on all three Cobalt motors.

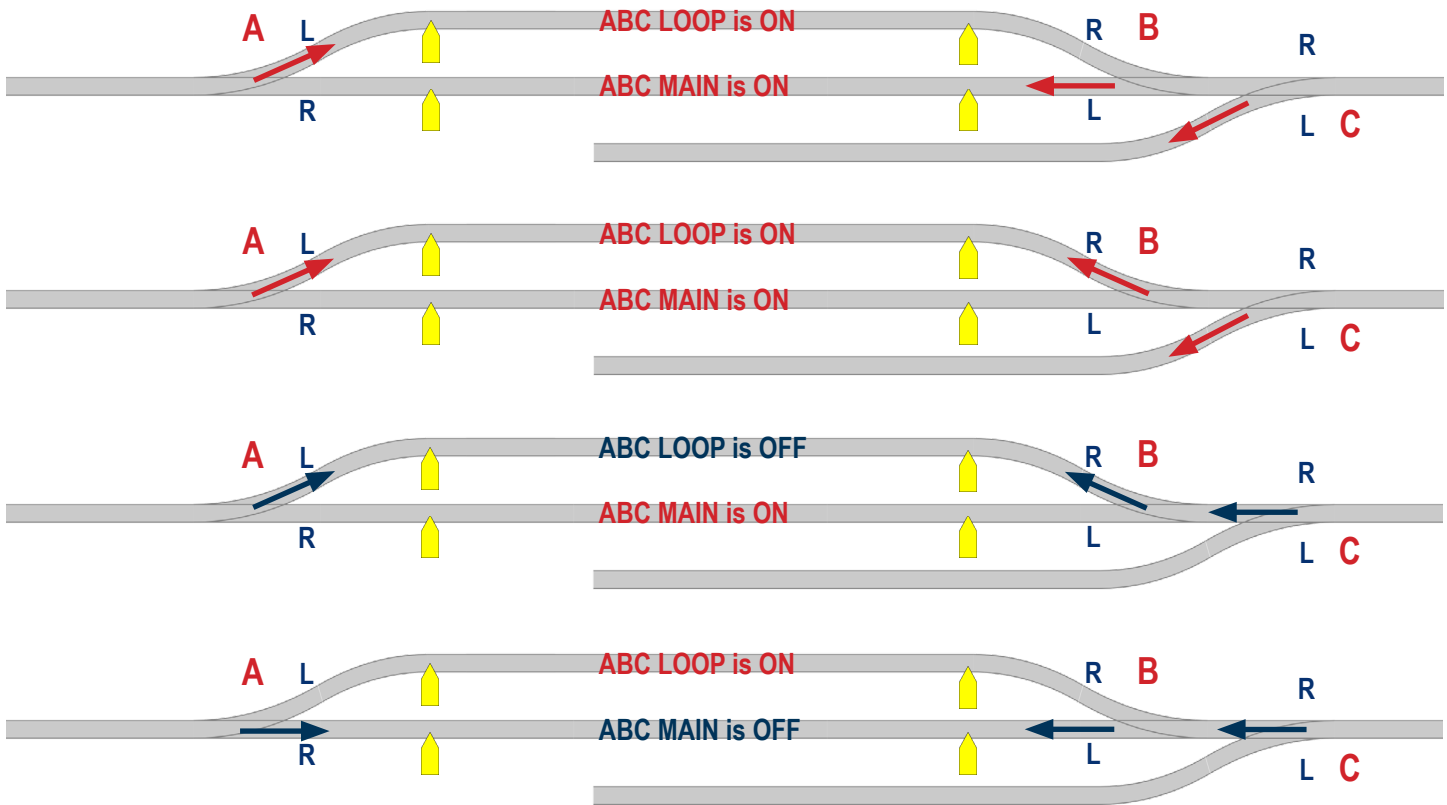

**Turning ABC on or off?**  
If the remote terminals are open, then ABC is on. If shorted, ABC will be off

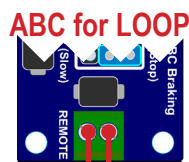

**REMOTE TERMINALS**  
Of course, the ABC on/off jumper must be in the ABC ON position to use them.

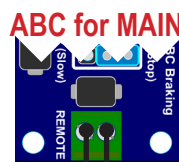

**RED wire:**  
switches the ABC module for LOOP.

**BLACK wire:**  
switches the ABC module for MAIN.

**GREEN wire:**  
Interlocks the ABC modules for the loop and main

**BLUE wire:**  
Interlocks the bay siding turnout (C) with ABC control for the loop and main

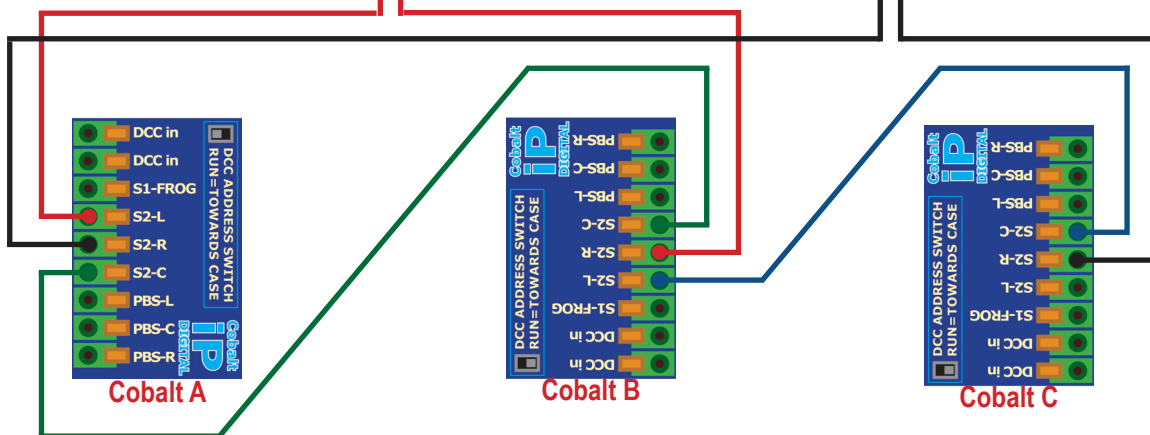

**Unique features, real performance and exceptional installability**

**Example #5A:** A fully automated hidden LOOP type storage yard with ABC & safety interlocks on entry and exit.

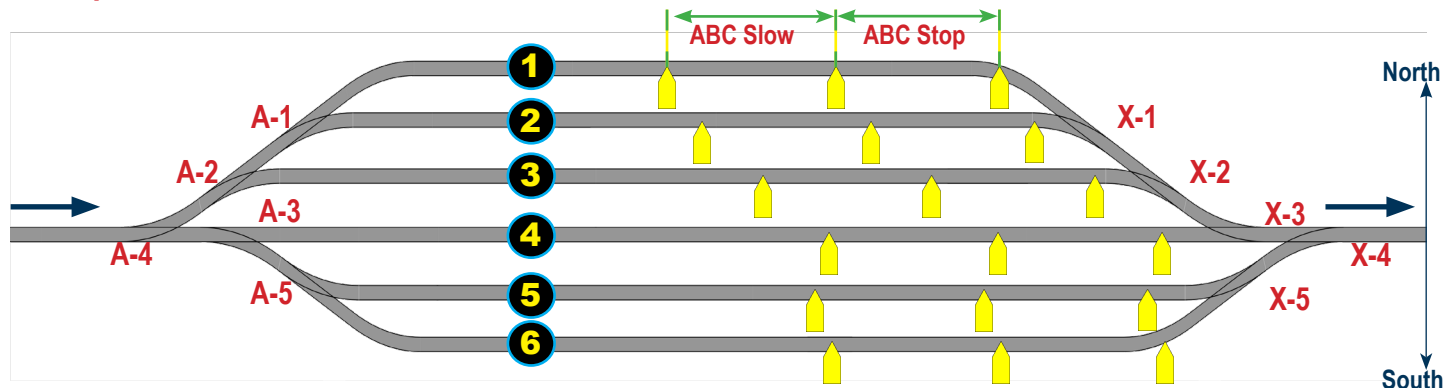

All of the ABC processes are covered in previous examples, so we are only going to describe “how to wire it” here. This will be enough for many - but if you need more, we will follow up with an extended description with more diagrams online. It will be called “ABC controlled storage yard” and you will find it in our manuals/advice section at [www.dccconcepts.com](http://www.dccconcepts.com).

**General assumptions:**

- CV48 has been adjusted to add delay / prevent locos speeding up when transiting from ABC slow sections to ABC stop sections.
- General wiring is as per normal DCC practice. As always, do it well and for best results do not compromise!
- Turnout motors are presumed to be from DCCconcepts Cobalt range: either Cobalt-SS, Omega, iP Analog or iP Digital. (This same approach will of course also work with other brands that have reliable SPDT switches for you to use.)
- Tracks are numbered 1 to 6, running from top to bottom.
- Entry & Exit turnouts are independently operated as the switches on the turnout motors will manage the ABC module switching.
- We will assume that yard arrival / entry is from the left, and the yard exit is towards the right.
- Turnouts will be named A-1 to A-5 (Arrival 1 to Arrival 5) and X-1 to X-5 (Exit 1 to Exit 5) in our notes below.
- Turnout position is described as north and south rather than normal or reversed or left and right to keep it understandable for all.

**Other guidance:**

- Entry & Exit ends of the yard should be independent as switches on the Cobalt motors will manage the ABC module switching.
- Because you can interface turnout motor switches with the external switching of the DCCconcepts ABC modules, interlocking of turnout motors and ABC control is easy - meaning that trains will ALWAYS stop where they should.
- Because the interlocking requires the route to be properly set before a train is released, once this is set up properly, a train cannot be driven out of the yard until the route is properly set, making it impossible for a train to run over a turnout that is set against it.
- When a train is stopped at the end of the storage yard tracks it will, by default, remember its speed settings. Therefore you could run an entire sequence of trains without doing anything other than setting entry and exit routes!
- Simple diode logic will let you select entry and exit routes with a single switch rather than needing individual motor control. Please see the diode matrix chart on page 43.
- The DCCconcepts DCW-DM1 diode matrix kit makes creating routes easy so we have used it here (see pages 42 and 43).
- To interlock ABC modules with the turnout switches, the “Remote” terminals of the ABC modules are linked to the SPDT switches on one or more Cobalt turnout motors. When the switch is OPEN, the ABC module is on, when closed, ABC module is OFF.
- Where a route uses more than one turnout motor, then the Cobalt motor’s on-board switches are wired in series, so that unless all motors are properly aligned, the module will not turn off and allow the train to proceed.
- A simple logic list will make setting this up relatively simple - some examples that may help you think your own designs through:
  - \* Access route for track 3 is A-4 North, A-2 South      \* Access route for track 5 is A-4 South, A-3 South, A-5 North
  - \* Exit route for track 1 is X-1 North, X-2 North, X-3 North, X4 North      \* Exit route for track 4 is X-3 South, X-4 North



**Unique features, real performance and exceptional installability**

**Example #5B:** Wiring the Cobalt motor SPDT switches so that they interlock ABC. This ensures that ONLY the ABC board relevant to the route out of the yard that is properly set up is turned off - allowing ONLY that loco to move.

- We really only need to control the ABC Stop boards to stop and release a loco
- But - if you DO want to turn both off, wire the remote terminals of the ABC Slow & ABC Stop boards together in parallel.

**Operations:**

- If ENTRY and EXIT ends are set the same, then the train will continue.
- If EXIT is not the same as ENTRY, the train will slow down and stop.

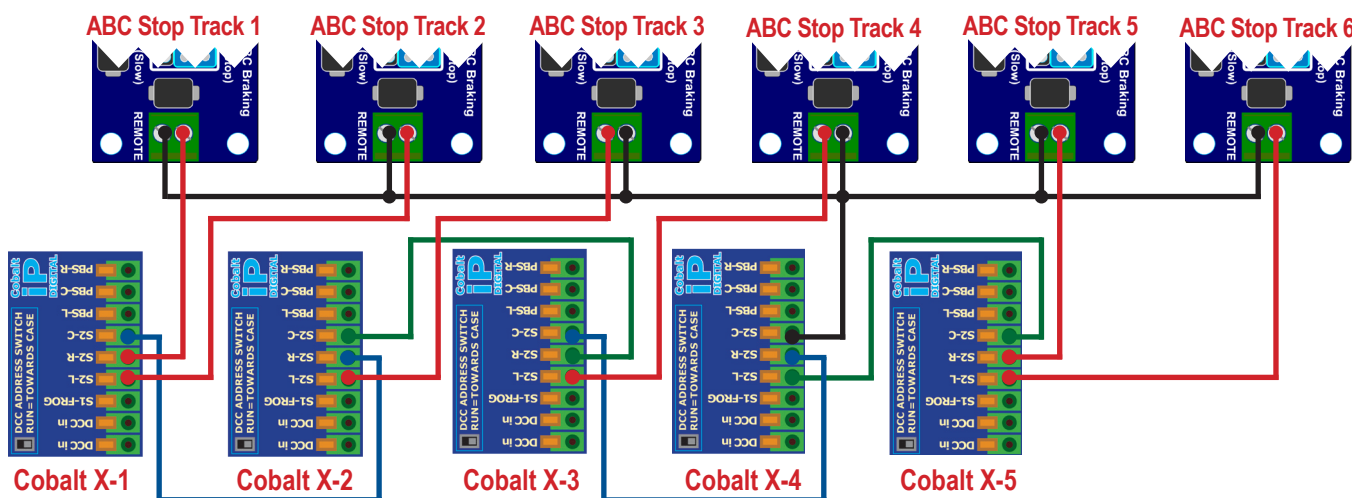
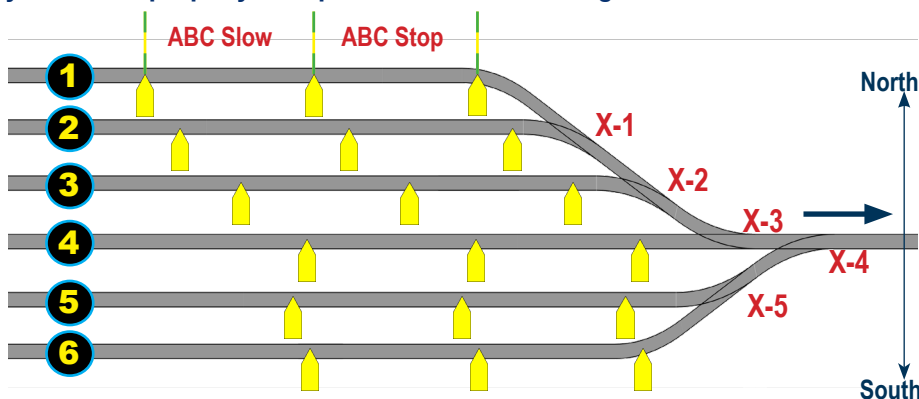

**RED wire:** Shows which wires control each ABC Stop module. Cobalt X-1 and X-5 each control two, the others just one.

**BLACK wires:** These are a common wire for all the ABC modules. Link it to Cobalt X-4 - it is then inter-linked to all other motors.

**GREEN & BLUE wires:** We alternated colour to make the wiring clearer. These wires complete the interlocking of the motors.

**Note on wiring the Cobalt SPDT switches:**

- Approach this one step at a time and it is quite easy to do.
- First wire the common and link it to X-4's COMMON switch terminal.
- Follow this by wiring the red switch wires, then add the green/blue. (No need for two colours of course)
- If you want MORE or LESS tracks, use this diagram and add or delete mid-positioned motors accordingly.
- If you need help with the wiring of a different yard design, then please contact us and we will do our best to assist you.

**A note about operating this yard:**

- You will need to adjust CV48 if your locos speed up when transiting from ABC slow sections to ABC stop sections (Page 31)
- Once the ABC boards are connected and the motors are wired for operation / interlocked as above, it is in fact ready to go if you wish to work manually changing one motor at a time
- If your DCC system allows it, you could easily create macros or "routes" for each entry and exit route.
- Alternately, diagrams C and D in this section show you how to set up simple "One button per route" diode matrix control.

**Unique features, real performance and exceptional installability**

**Example #5C:** Wiring the Cobalt motor Manual control switches so that one button can set each ENTRY route.

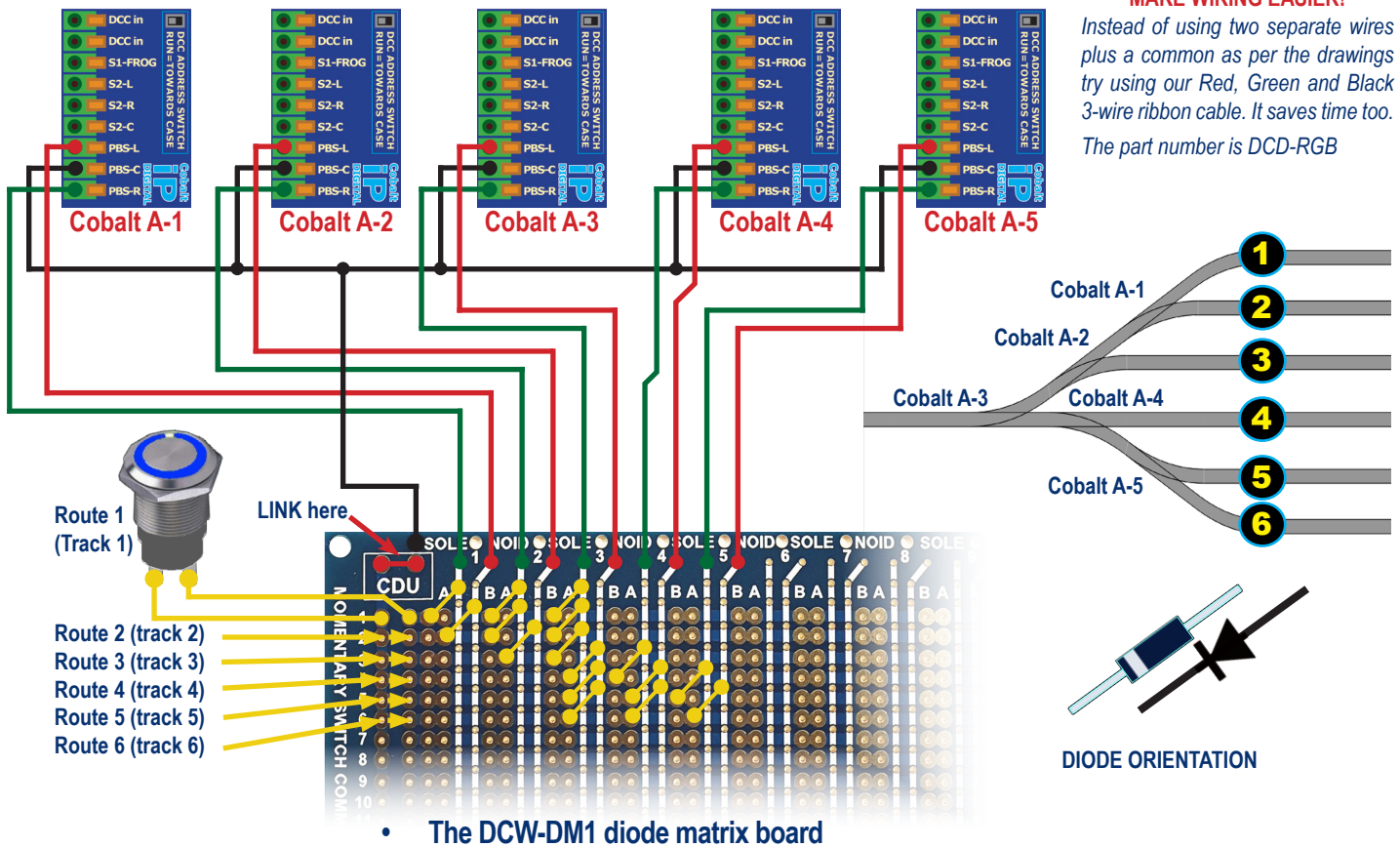

Both the entry and exit route-control diagrams will work equally well with Cobalt iP Digital or Cobalt-SS.

Of course they will also work well with our Cobalt iP Analog/Omega turnout motors in combination with our AD2, AD4, AD6 or AD8 FX series accessory decoders. You could also just create a "Route" or macro in your DCC system!

Don't be intimidated by the appearance of lots of wires. It is after all only the same set of connection 5 times!

- You can use simple push-button momentary switches for route control if you wish.
- Choose ANY normally off push button. (We do recommend that you buy good quality switches though - low cost switches are subject to failure and contact "Bounce".) Whatever you choose, the switches will NOT be subjected to high power.
- If you are using DCCconcepts Cobalt motors, you should NOT add power to the diode matrix at all as it will damage the motors. You should orient the diodes as per the inset image in each diagram.

Using solenoids instead of Cobalt:

- If you are using solenoids, you will need a power supply and a CDU. The DCCconcepts CDU-2 is by far the best approach as it has huge power ability and is one "plug in box" that does the lot with no wiring other than the output connections.
- For solenoid use, please swap all the diodes end-for-end but use the same layout (also replace the LINK with a CDU)
- Solenoids will use the left/right/common connections as per the Diode matrix board instructions. The switch connections would exactly be the same. The Diode matrix instructions in the DCW-DM1 pack cover all solenoid wiring.

**Unique features, real performance and exceptional installability**

**Example #5D: Wiring the Cobalt motor Manual control switches so that one button can set each EXIT route.**

**MAKE WIRING EASIER!**

Instead of using two separate wires plus a common as per the drawings try using our Red, Green and Black 3-wire ribbon cable. It saves time too.

The part number is DCD-RGB

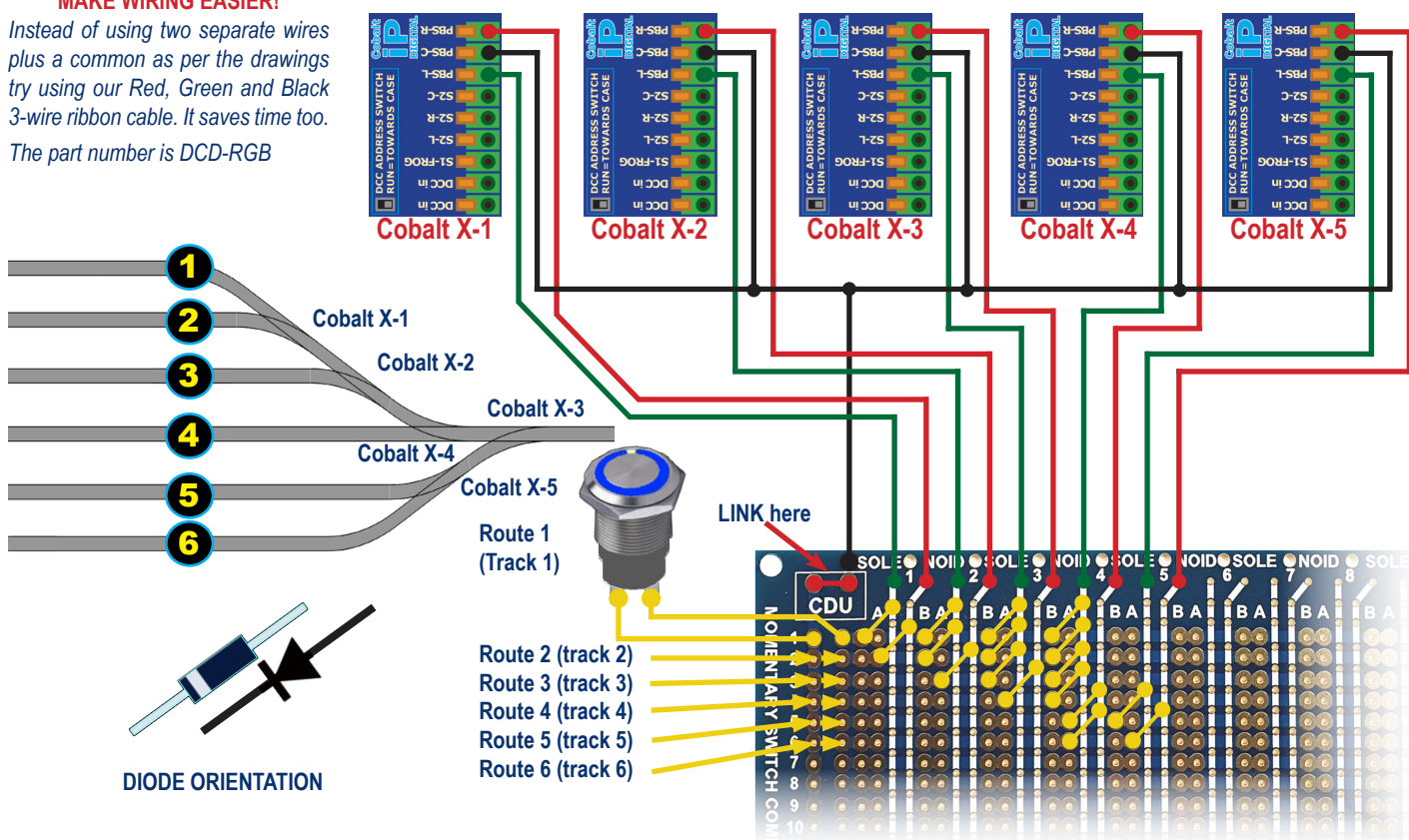

• The DCW-DM1 diode matrix board

Both the entry and exit route-control diagrams will work equally well with Cobalt iP Digital or Cobalt-SS.

Of course they will also work well with our Cobalt iP Analog/Omega turnout motors in combination with our AD1-HP, AD2, AD4, AD6 or AD8 Accessory decoders. You could also just create a "Route" or macro in your DCC system!

Don't be intimidated by the appearance of lots of wires. It is after all only the same set of connection several times!

- You can use simple push-button momentary switches for route control if you wish.
- Choose ANY normally off push button. (We do recommend that you buy good quality switches though - low cost switches are subject to failure and contact "Bounce".) Whatever you choose, the switches will NOT be subjected to high power.
- If you are using DCCconcepts Cobalt motors, you should NOT add power to the diode matrix at all as it will damage the motors. and you should orient the diodes as per the inset image in each diagram.

Using solenoids instead of Cobalt:

- If you are using solenoids, you will need a power supply and a CDU. The DCCconcepts CDU-2 is by far the best approach as it has huge power ability and is one "plug in box" that does the lot with no wiring other than the output connections.
- For solenoid use, please swap all the diodes end-for-end but use the same matrix layout as per page 42.
- Solenoids will use the left/right/common connections as per the Diode matrix board instructions. The switch connections would exactly be the same. The Diode matrix instructions in the DCW-DM1 pack cover all solenoid wiring.



## DCCconcepts **Zen** BLACK ABC Shuttle.

Automatic Shuttle operation with intermediate station stops, all managed by your **Zen** BLACK decoder. The basic DCCconcepts Zen ABC shuttle is simplicity itself.

Once you have installed DCCconcepts ABC-capable Zen Black decoder, you will need only two DCD-ABC modules to act as stopping triggers for the shuttle train. If you would like to have one or more intermediate stops, just add more ABC modules.

- Orient the modules one way for “Stop & reverse”, the other for “Stop & continue”.
- Set CV27 to 4 to activate the shuttle ability.
- Set the timer CVs for end of shuttle stop and reverse (CV59). If needed, also set the Stop and Continue timer (CV60)
- You are now able to run a shuttle. Changing other CVs will let you adjust slowdown or other things if you wish.

### SHUTTLE example #1: DCCconcepts ABC Shuttle - The basic end-to-end shuttle with no intermediate stops

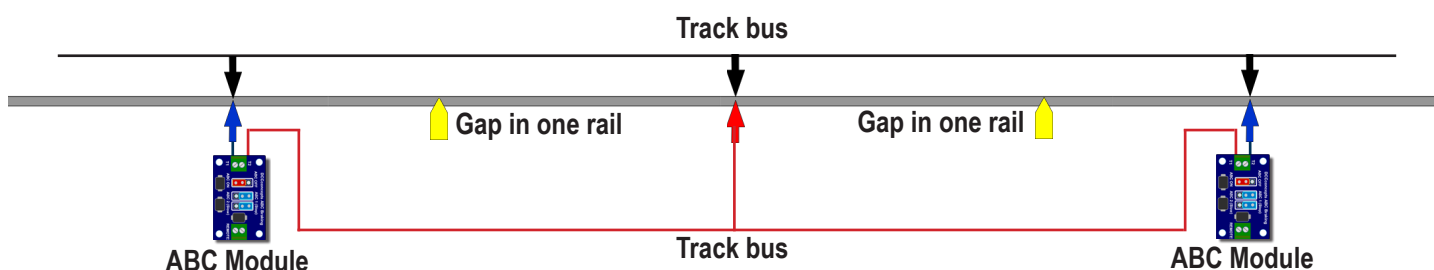

The basic DCCconcepts ABC shuttle is a simple thing to set up.

You will need only two DCD-ABC modules to act as the stopping triggers for the shuttle train.

- Gap the rails to create the end-stop sections. (As for other stop areas, one loco length plus stopping distance).
- Install the two ABC modules. Set the ABC module header switches to the ABC-1 position.

#### Decoder Set-up:

- Set the decoder - DCCconcepts ABC Shuttle activity is initiated by setting CV27 to 4.
- Set the stop timer CV59. The delay is 10 seconds for each step (experiment low, set final time later).
- Start the loco running with your DCC system, then leave the shuttle operation to your Zen decoder. (If it does not stop initially, then change ABC 1 to ABC 2 by moving the Blue headers)
- If you want to adjust the rate at which the train stops, Adjust CV4. Alternately, adjust CV55/56/57/58.

#### Note please:

- Shuttle mode does not prevent normal operation. (providing ABC modules are off OR loco is in a non-shuttle area)
- A loco set to respond to shuttle mode can also be driven normally.
- You can take over driving simply by using the throttle control of your DCC system at any time. If the train is currently stopped at an end or intermediate stop, you can take over by pressing the direction button OR turning ABC modules off.

Enjoy playing with your shuttle train - it is a great way to get used to ABC braking and how it works and remember, if you get stuck, lost or confused, just set CV 8 to 8 to re-set the decoder to default settings & start again.



Zen Decoders are imagined, designed and manufactured by DCCconcepts Ltd  
 Our showroom and offices are located in Settle, North Yorkshire BD24 9RP, England **44**  
 Phone: +44 (0) 1729 821 080 \* sales@dccconcepts.com \* www.dccconcepts.com

**DCCconcepts Zen BLACK ABC Shuttle.**

Automatic Shuttle operation with intermediate station stops, all managed by your **Zen** BLACK decoder.

**SHUTTLE example #2:** DCCconcepts ABC Shuttle - An end-to-end shuttle with an added station stop.

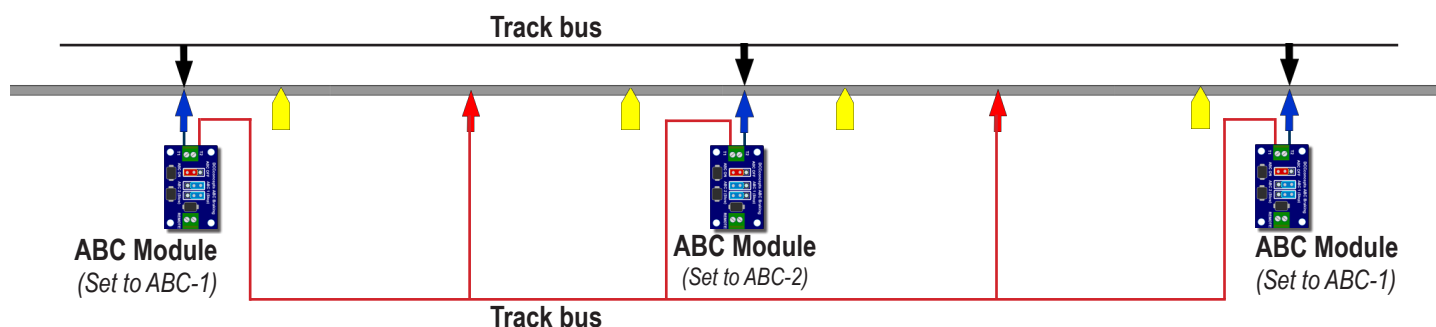

**Adding one or more intermediate station stops to DCCconcepts ABC shuttle is almost no effort at all!**

You can add one, two or a dozen or more station stops - and apart from setting the “stop time” in the decoder, there are no other adjustments needed if the line is a dedicated shuttle track.

It is very simple and low cost to add them as all you will need is one additional DCD-ABC module per station stop... Installation is also easy - just a couple of rail cuts to make and a few minutes to wire the ABC module to the rail.

- Gap the rails to create the intermediate section. (As for other stopping areas, one loco length plus stopping distance).
- Install the ABC module. Set the ABC modules two Blue switch headers to the ABC-2 position.

Decoder Set-up:

- Set the decoder - DCCconcepts ABC Shuttle activity is initiated by setting CV27 to 4.
- Set the INTERMEDIATE stop timer CV60. The delay is 10 seconds or each step (experiment low, set final time later).
- Start the loco running with your DCC system, then leave the shuttle operation to your Zen decoder.
- The loco should now stop and wait a while when it arrives at the intermediate station. (If it stops then reverses instead of proceeding, change the ABC module’s Blue switch headers)
- If you want to adjust the rate at which the train stops, adjust CV4. Alternately, adjust CV55/56/57/58.

Note please:

- Shuttle mode does not prevent normal train driving in non-ABC areas of operation.
- A loco set to respond to shuttle mode can also be driven normally.
- You can also take over driving during a station stop by pressing the direction switch on your DCC controller then driving the train out of the section - OR by turning the ABC section off.

Enjoy operating your shuttle train - it is a great way to get used to ABC braking and how it works and remember, if you get stuck, lost or confused, just set CV 8 to 8 to re-set the decoder to default settings & start again.

**DCCconcepts Zen BLACK ABC Shuttle.**

Automatic Shuttle operation with intermediate station stops, all managed by your **Zen** BLACK decoder.

**SHUTTLE example #3:** DCCconcepts ABC Shuttle - More than one shuttle train running, with a passing loop in the middle for added interest and flexibility of operation.

*Now the first examples have established what things are, we'll just focus on the lines and symbols to keep the drawings clearer!*

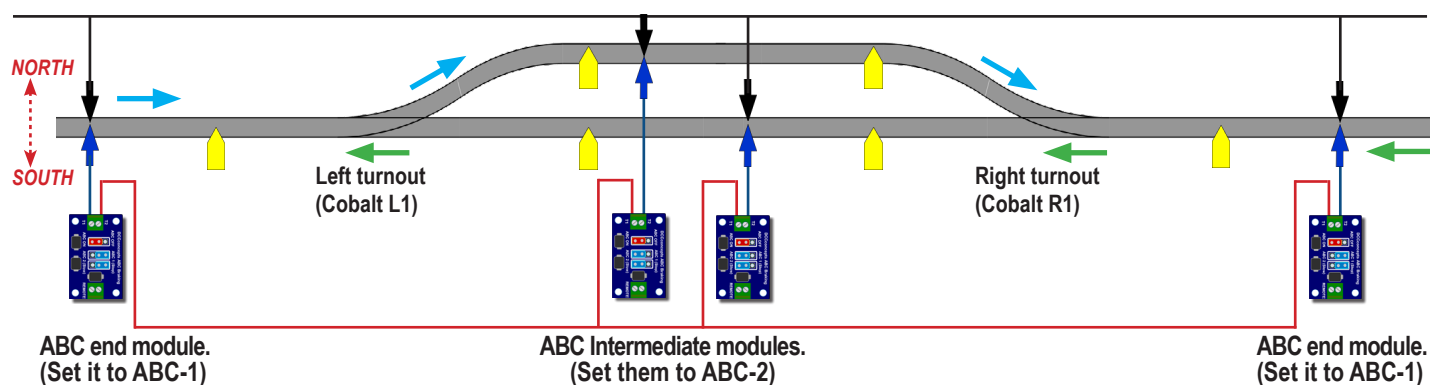

**Setup, Settings and the interfacing of ABC modules with turnouts for this dual shuttle configuration.**

**The ABC modules:**

- Wire as per the diagram.
- Set the two ABC modules at each end of the shuttle track to ABC-1
- Set the two ABC modules in the centre of the shuttle track to ABC-2

**The Decoder settings:**

- Set CV27 to 4 to set the decoder to shuttle mode.
- Set shuttle END-stop wait time with CV55.
- Set shuttle action for intermediate stop sections by setting CV56 to 2. This tells the decoder to stop & stay at an intermediate stop section until the ABC module is turned off. (We will link them to the Cobalt motors driving the turnouts to achieve this).
- Set up the decoder deceleration to your preference. (You can leave at default or use CVs 4, 55, 58 to influence this)

**The interlocking of ABC modules and Cobalt motor-driven turnout control to prevent conflict:**

**Please see the drawing on the next page for how this is done.**

- Using standard UK practice, a train heading West > East (pale blue arrows) would take the route through the upper loop and a train heading East < West (pale green arrows) would transit the centre area via the lower loop (main).
- Interface the remote terminals of ABC modules L1 and L2 with the Cobalt turnout motors SPDT switches so that they are either on or off depending on the turnout position.... OR can allow direct transit without stopping.
- Wire the switch terminals of the Cobalt turnout motors so that you have several options, each selected by a single button. (1) straight through via loop (2) straight through via Main (3) Alternate turnout position to stop trains at the station and finally, (4) release trains when stopped at the station via option 3
- The above can be automated with some thought. Perhaps, add detectors or create a route via your DCC system to switch the turnouts digitally. (Possible with either Cobalt iP Digital or iP Analog / Omega via an AD-Series DCC decoder).

Unique features, real performance and exceptional installability

DCCconcepts **Zen** BLACK ABC Shuttle.

Automatic Shuttle operation with intermediate station stops, all managed by your **Zen** BLACK decoder.

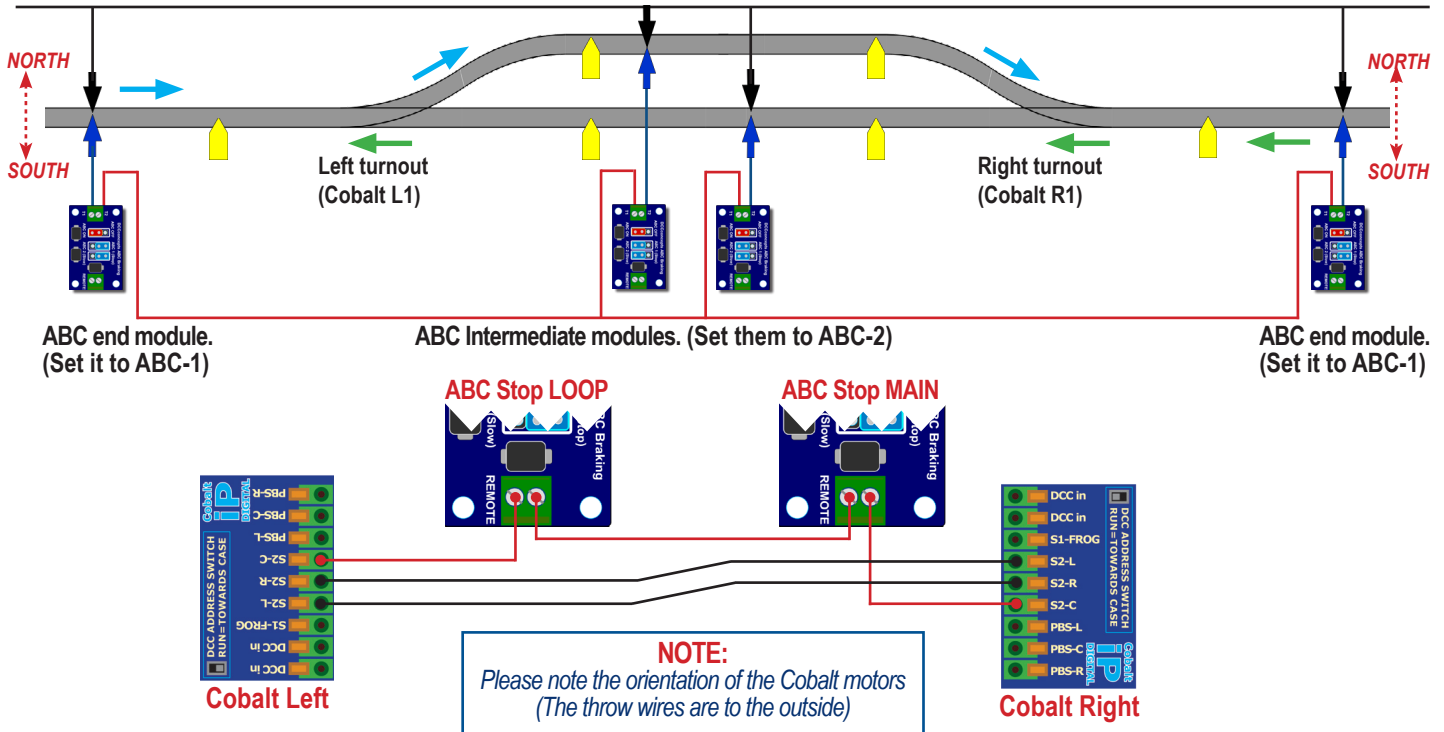

Wiring the ABC modules:

- This diagram shows how to wire the ABC modules, interlocking them to be ON when L1 = North and R1 = South.
- In all other switch positions (L1 = North, R1 = North or L1 = South and R1 = south), ABC modules will be off or inactive.

Controlling the Cobalt motors:

- You could use Cobalt Alpha, your DCC handset or route control (a macro) to change the motors if you wish.
- Basic control: using standard SPDT switches, this is how we do it. Indication is via the switch toggle position as below.

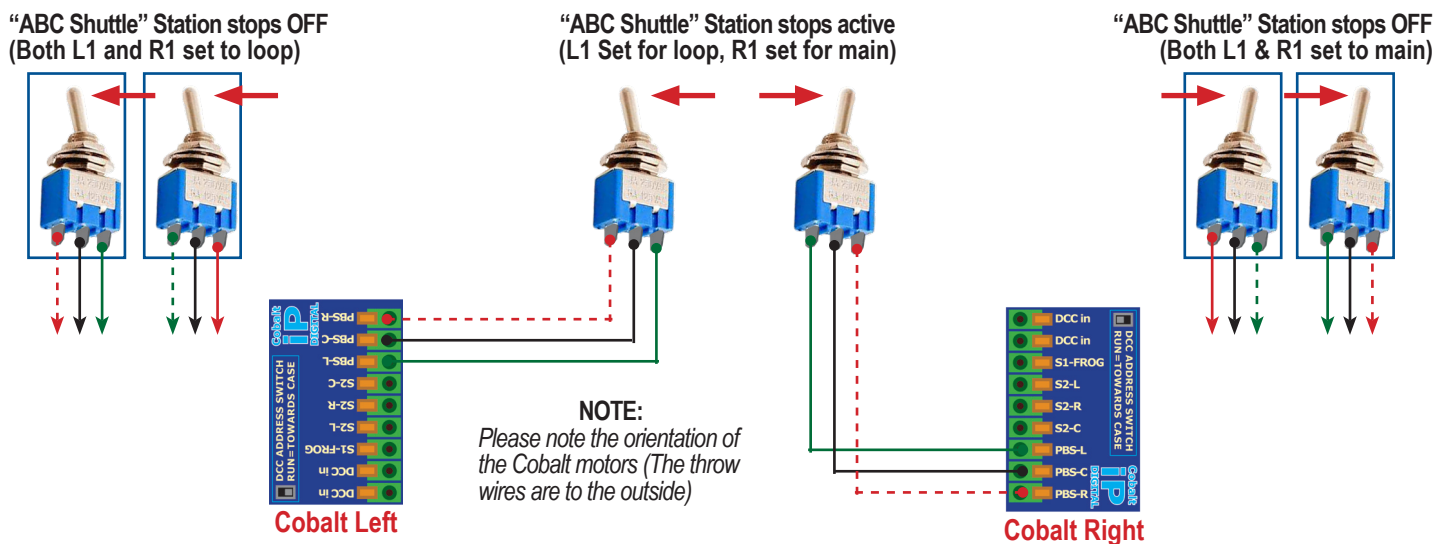

**Unique features, real performance and exceptional installability**

**The DCD-BODC control module:** Connecting the DCD-ABC control module & using the onboard header switches. Brake on DC has a simpler structure than ABC. Basic principles are the same for all uses, so just one diagram is needed here.

**Wiring the DCD-ABC module - Connections.**

- Connect the DCC BUS terminals to the DCC power bus (The DCC track power bus - see diagram below).
- Connect terminals T1 & T2 to the track power bus (keep the same red/black relationship as the DCC BUS wires)
- Connect the REMOTE terminals to any switch that can give you an on-off condition for the BODC board if desired.

**Operating the DCD-BODC module - The header switches.**

- To turn the BODC section on or off at the PCB level move the RED header.
- If you want to use an external SPST on/off switch to turn the BODC module on or off at will from the panel, connect it to the REMOTE terminals.
- To invert the BODC signal to change the STOP direction, move the BLUE header (Loco stops when FWD or loco stops when in REV are the options)
- For automated control of the BODC board on/off condition, connect a Cobalt turnout motor switch, relay or similar device to the REMOTE terminals.

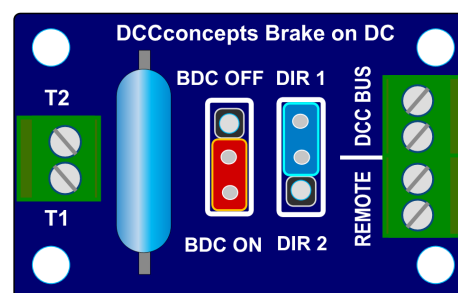

**Example #1: Basic BODC use and connection, BODC stopping using one DCD-BODC module.**

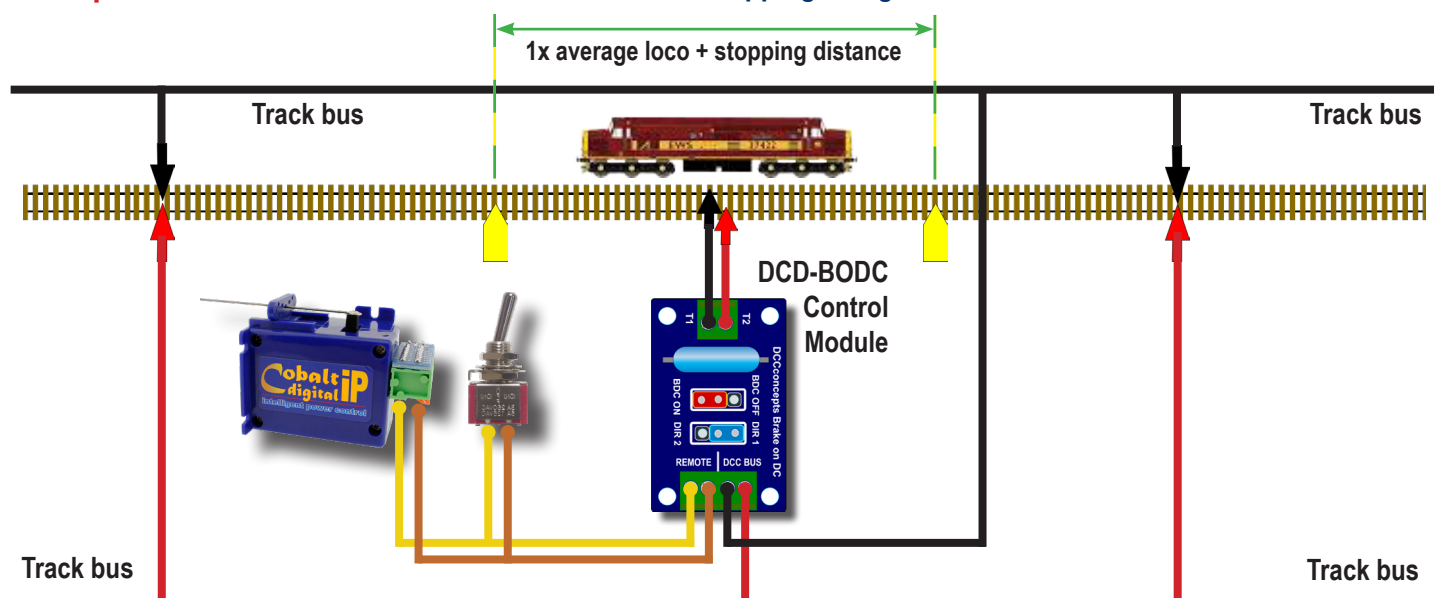

**Learning about BODC - SETUP and CV changes to activate Advanced BODC for a single section**

- Cut one rail, making the BODC stop section as long as 1 loco plus your preferred / planned braking distance (as above).
- Connect wiring and the DCD-BODC board to the test track as per this diagram.
- Set CV27 as per your choice in the chart below, and enjoy experimenting with Advanced Zen Brake on DC operation.

CV27=	Expected ZEN Advanced Brake on DC action if CV is set to that value	Related CVs
16	Advanced Brake on DC. Stop if BODC on, right rail more (+), left more (-)	DC Running OFF
32	Advanced Brake on DC. Stop if BODC on, right rail more (-), left more (+)	DC Running OFF
48	Advanced Brake on DC. Stop in either direction if the BODC unit is ON	DC Running OFF







#### ADDED NOTES:

As we continue to play with our ZEN decoders, we sometimes find things that we would like to add to the manuals.

This page will contain some further clarifications and tips on decoder use as we find them.

- Reversing out of an ABC section: To be able to simply press “reverse” and drive out of an active ABC section, the loco needs to have entered that section in forward. Therefore, please orient locos accordingly if using ABC.
- CV27 differences - ABC module reactions are always relative to forward or reverse with a locomotive if CV27 is set to 1 or 2. So, if you have CV27 set to 1 or 2 and you physically turn a loco around, you will need to swap the ABC module orientations too. However if CV27 = 3, then action will be bi-directional without ABC module change.
- Power interruption - if power is removed while the loco is stopped within an ABC stop section, then the loco can only be reversed out (REV on controller, not alternate direction) when power is restored. As a general guide, other than for stop sections at any terminus or stub ended yard, do not turn the layout off until all locos are properly stopped in a normal driving area of the layout.
- Do not use POM while a loco is in an ABC a slow or stop section. If you do it WILL be recorded by the decoder but the changes you make may not actually take effect until the loco enters a normal running track area.



Zen Decoders are imagined, designed and manufactured by DCCconcepts Ltd  
Our showroom and offices are located in Settle, North Yorkshire BD24 9RP, England  
Phone: +44 (0) 1729 821 080 \* [sales@dccconcepts.com](mailto:sales@dccconcepts.com) \* [www.dccconcepts.com](http://www.dccconcepts.com)